

# Installation and User Guide

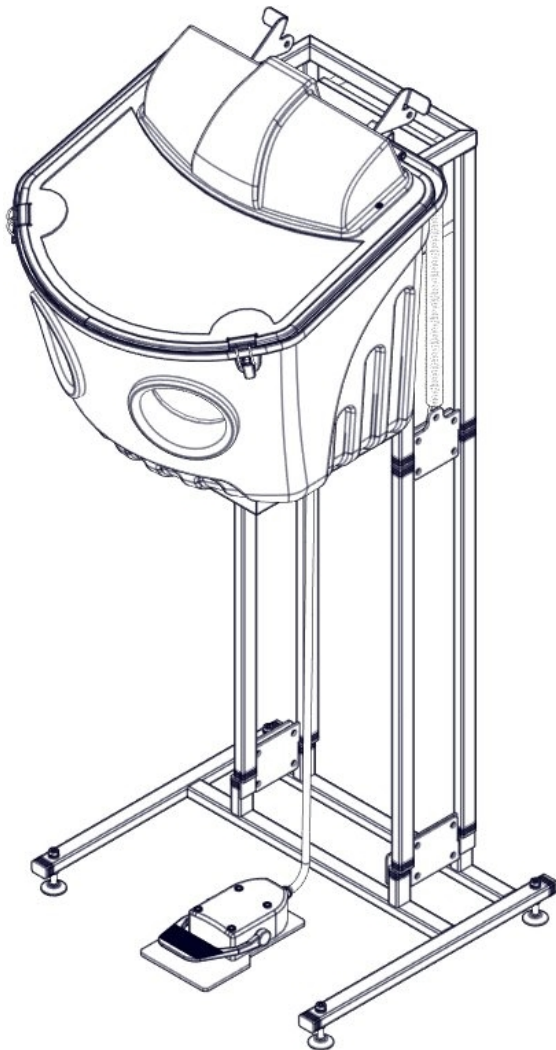

# stratasys®

Objet WaterJet  
Cleaning System



## Copyright

Copyright © 2012-2019 Stratasy Ltd. All rights reserved.

No part of this document may be photocopied, reproduced, or translated into any human or computer language in any form, nor stored in a database or retrieval system, without prior permission in writing from Stratasy. This document may be printed for internal use only. All copies, shall contain a full copy of this copyright notice.

[www.stratasy.com](http://www.stratasy.com)

## Trademarks

Stratasy and Objet are trademarks of Stratasy and/or subsidiaries or affiliates and may be registered in certain jurisdictions. All other product names and trademarks are the property of their respective owners.

## Equipment Recycling



In the European Union, this symbol indicates that when the last user wishes to discard a product, it must be sent to appropriate facilities for recovery and recycling. For information about proper disposal, check your purchase contract, or contact the supplier of the equipment.

## Liability

Stratasy shall not be liable for errors contained herein or for incidental or consequential damages in connection with the furnishing, performance, or use of this material. Stratasy makes no warranty of any kind with regard to this material, including, but not limited to, the implied warranties of merchantability and fitness for a particular purpose. It is the responsibility of the system owner/material buyer to determine that Stratasy material is safe, lawful, and technically suitable for the intended application as well as identify the proper disposal (or recycling) method consistent with local environmental regulations. Except as provided in Stratasy's standard conditions of sale, Stratasy shall not be responsible for any loss resulting from any use of its products described herein.

## Disclaimers

Customer acknowledges the contents of this document and that Stratasy parts, materials, and supplier are subject to its standard terms and conditions, available on <http://www.stratasy.com/legal/terms-and-conditions-of-sale>, which are incorporated herein by reference.

The specifications and/or information on which this document is based are subject to change without notice.

## Feedback

If you have any questions or comments about the way information is presented in this document, or if you have any suggestions for future editions, please send a message to [c-support@stratasy.com](mailto:c-support@stratasy.com).

# Contents

---

<b>Introduction</b> .....	<b>5</b>
Objet WaterJet .....	6
For More Information .....	6
Terms Used in This Guide .....	6
<b>Safety</b> .....	<b>7</b>
Safety Guidelines .....	8
First Aid for Working With Printing Materials .....	9
Contact with Skin .....	9
Contact with Eyes .....	9
Ingestion .....	9
Inhalation .....	10
Waste Disposal .....	10
<b>Overview</b> .....	<b>11</b>
Main Components .....	12
Size and Weight .....	13
Electrical Box .....	14
Power Sockets and Cables .....	14
Cover Latches .....	15
Nozzle Selection and Flow Regulation .....	15
Foot Pedal .....	16
Waste Filter .....	16
Water Inlet .....	16
<b>Installation</b> .....	<b>17</b>
Mounting the WaterJet on the Stand .....	18
Preparing the Base .....	18
Placing the WaterJet on the Counter Stand .....	19
Placing the WaterJet on the Floor Stand .....	20
Leveling the WaterJet Unit .....	22
WaterJet Connections .....	23
Connecting the Water Supply .....	24
Connecting the Drain Hose .....	25
Connecting the Power Cables .....	26
<b>Cleaning Models</b> .....	<b>28</b>
Cleaning Process .....	29
Removing Excess Support Material by Hand .....	29
Capacity .....	29
Removing Support Material with the WaterJet .....	30
Spray Nozzle .....	30
Jet Nozzle .....	30

Operating the WaterJet .....	31
After Using the WaterJet .....	32
Removing Support Material with Sodium Hydroxide .....	32
<b>Maintenance .....</b>	<b>33</b>
Replacing a Lamp .....	34
Replacing the Wiper Fuse .....	36
Maintaining the Water Pressure Pump .....	37
Maintenance .....	37
Troubleshooting .....	38

# 1

## Introduction

<b>Objet WaterJet .....</b>	<b>6</b>
<b>For More Information .....</b>	<b>6</b>
<b>Terms Used in This Guide .....</b>	<b>6</b>

# Objet WaterJet

The Objet WaterJet cleaning unit provides easy and fast cleaning of Support material from models printed on Stratasys 3D printing systems.

This user guide provides instructions for installing, operating and maintaining the following systems:

- OBJ-01200—Objet WaterJet (110–120-volt)
- OBJ-01201—Objet WaterJet(220–240-volt)
- OBJ-01202—Objet WaterJet (100-volt)

## For More Information

Visit <http://www.stratasys.com> for information on Stratasys, its technologies, products, and application methods.

If you have any questions about the information presented in this document, or if you have any comments or suggestions for future editions, please send a message to [c-support@stratasys.com](mailto:c-support@stratasys.com).

## Terms Used in This Guide

resin	The base substance from which photopolymer printing materials are made for use in Stratasys printers.
Model material	Material used for building models.
Support material	Material used for supporting the structure of models during production. This material is later removed with the WaterJet.
jet nozzle	Nozzle for removing Support material from delicate parts.
spray nozzle	Nozzle for removing Support material from parts that are not delicate.

# 2

## Safety

<b>Safety Guidelines</b> .....	<b>8</b>
<b>First Aid for Working With Printing Materials</b> .....	<b>9</b>
Contact with Skin .....	9
Contact with Eyes .....	9
Ingestion .....	9
Inhalation .....	10
<b>Waste Disposal</b> .....	<b>10</b>

# Safety Guidelines

The following general guidelines, together with the instructions provided throughout this user guide, ensure user safety while operating and maintaining the WaterJet system. **If the system is not operated as specified, the user's safety might be compromised.**

- Installation and removal of the WaterJet system should only be done by qualified service personnel.
- Service operations should be performed only by personnel who have been instructed in relevant safety precautions.
- All personnel operating or maintaining the WaterJet system should know the location of first aid and emergency equipment and how to use them. **Never block access to this equipment.**
- Read and follow safety and maintenance instructions that come with the water pressure pump.
- Do **not** direct the pressurized stream of water at people, animals or objects.
- Check the WaterJet hoses before each cleaning session. Do **not** operate the WaterJet if a hose is damaged or crimped.
- Never operate the WaterJet while the cover is open.
- Wear earplugs for protection against loud noise.
- If you supply or replace the power cable, make sure that it meets the requirements specified in this document.
- The power cable should be connected at an easily accessible outlet near the WaterJet.
- The wall outlet must be protected by a residual current device (RCD).
- Never connect the power plug to an outlet that does not have a ground (earth) wire, and never disconnect the ground. Doing so can expose the operator to serious danger from electric shock.
- Protect electrical connections from contact with water spray and moisture.
- Never insert screwdrivers, wires, or other objects into the pump or power supply housing.
- Several parts of the WaterJet can remain extremely hot after use. Avoid touching the main power supply, the wiper motor, the water pump and the lamps until they have cooled.
- Notify co-workers and those who have access to the WaterJet system before beginning non-routine and hazardous work.
- Report any potential dangers and safety-related accidents to your safety officer or to other appropriate authorities.



# First Aid for Working With Printing Materials

Fully cured models present no safety or health-related issues. If skin or eyes come into contact with uncured printing material, wash the area immediately and thoroughly with water, and follow the first-aid instructions below.

## Contact with Skin

If uncured printing material comes in contact with skin:

- Immediately wash the affected area thoroughly with soap and cool water, and then remove contaminated clothing. Pay particular attention to flushing the hair, ears, nose and other parts of the body that are not easily cleaned.
- Use cool water to prevent skin pores from opening, so that the liquid material does not easily penetrate the skin.
- Do not use solvents to clean skin.
- If large areas of skin have been exposed, or if prolonged contact results in blisters, seek medical attention. In any case, if irritation persists, seek medical attention.
- Avoid the accidental transfer of printing material from the hands to other areas of the body, especially to the eyes.
- If protective cream was used, do not reapply it until the skin has been completely cleansed.

## Contact with Eyes

If uncured printing material comes in contact with the eyes:

- Flush immediately with large amounts of water for 15 minutes and seek medical attention.
- Avoid sunlight, fluorescent light, and other sources of ultraviolet radiation.

The wearing of contact lenses when handling liquid printing materials is not recommended. If the liquid splashes into the eyes when contact lenses are worn:

- Immediately remove the lenses and flush the eyes with water.
- Clean and disinfect the contaminated lenses.
- Do not wear contact lenses until eye irritation disappears.

## Ingestion

If printing material is swallowed, refer to the instructions included with the cartridge. **Seek medical attention immediately.**

## Inhalation

Vapors from printing materials can be irritating to the respiratory system. If respiratory irritation occurs:

- Expose the victim to fresh air immediately.
- Seek medical attention immediately.
- Keep the patient warm but not hot.
- Never feed anything by mouth to an unconscious person.
- Oxygen should be administered by authorized personnel only.
- If the victim has stopped breathing, perform artificial respiration or cardiopulmonary resuscitation.

## Waste Disposal

Fully cured models present no special safety or health-related issues. However, check if local regulations regard cured and partially cured resins as hazardous industrial waste, and comply with all applicable regulations governing their disposal.

# 3

## Overview

<b>Main Components</b> .....	12
<b>Size and Weight</b> .....	13
<b>Electrical Box</b> .....	14
<b>Power Sockets and Cables</b> .....	14
<b>Cover Latches</b> .....	15
<b>Nozzle Selection and Flow Regulation</b> .....	15
<b>Foot Pedal</b> .....	16
<b>Waste Filter</b> .....	16
<b>Water Inlet</b> .....	16

# Main Components

The Objet WaterJet system consists of the following main components:

1. WaterJet unit (and stand)
2. water pressure pump
3. metal base
4. stand extensions

Figure 1 WaterJet system components

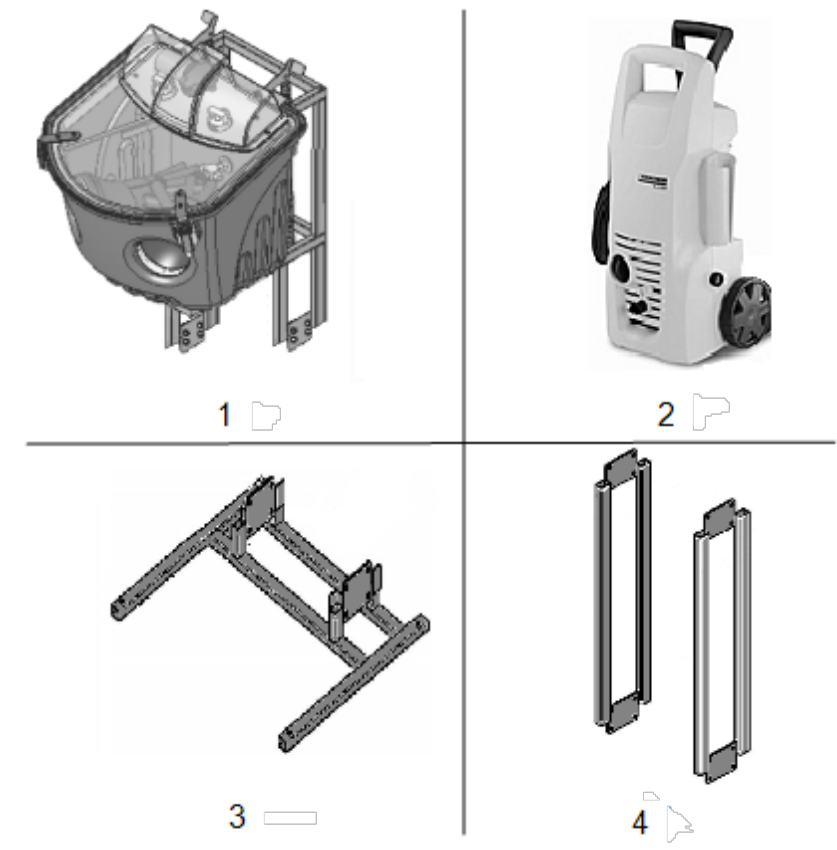

**Note:**

The water pressure pump supplied with the WaterJet might differ from the water pressure pump shown above.

You can configure the Objet WaterJet unit to stand on the floor or on a table by adding or removing the stand extensions.

# Size and Weight

The following table lists the size and weight of the Objet WaterJet unit and water pump.

Unit		W × H* × D (cm)	W × H* × D (in.)	Weight
WaterJet with table stand		58 × 75 × 70	22.8 × 29.5 × 27.5	25.6 kg / 56.3 lb
WaterJet with floor stand		58 × 155 × 70	22.8 × 61 × 27.5	30 kg / 66 lb
Water Pressure Pump	220-240 V	29.5 × 55.6 × 24	11.6 × 21.9 × 9.4	9 kg / 19.8 lb
	110-120 V	31.8 × 57.2 × 22.9	12.5 × 22.5 × 9	7 kg / 15.4 lb
	100 V	22.9 × 58.4 × 35.6	9 × 23 × 14	7.3 kg / 16 lb

\* When its cover is open, the effective height of the WaterJet unit increases by 25 cm (9.8 inches).

Figure 2 Dimensions of the WaterJet unit installed on a table

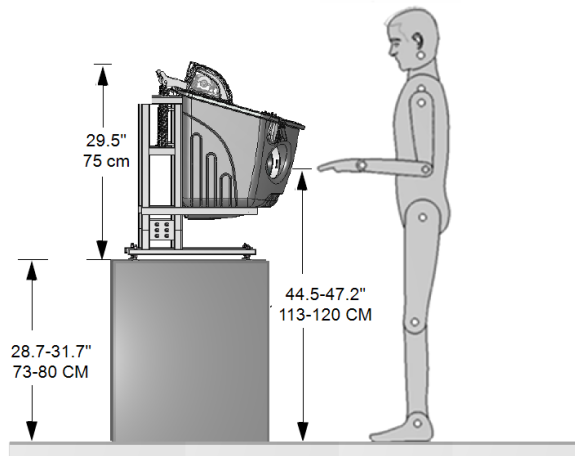
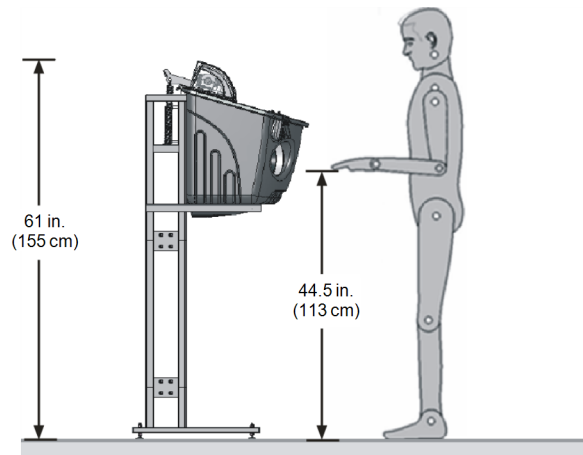

Figure 3 Dimensions of the WaterJet unit installed with stand extensions



# Electrical Box

A power switch located on the electrical box (see Figure 4), on the back of the WaterJet unit turns the entire system on and off. Therefore, the switch on the water pump can be left on.

The lamps inside the WaterJet turn on when the WaterJet is switched on.

Figure 4 Electrical box at the back of the WaterJet unit

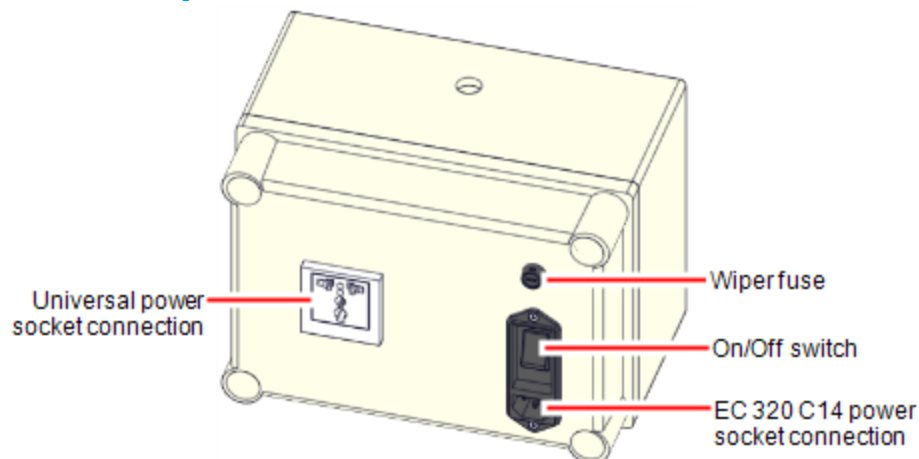

## Power Sockets and Cables

Two power sockets are located at the back of the WaterJet unit:

- a universal power socket  
The power cable from water pressure pump connects to this socket.
- an IEC 320 C14 power socket  
The main power cable connects to this socket.



### **Warning: Electrical Hazard**

Leakage currents could cause serious electrical shock. Make sure that the wall socket conforms to the requirements specified in the Site Preparation Guide.

To obtain the Site Preparation Guide, [click here](#) or contact your Stratasys representative.

# Cover Latches

Two latches on the front of the WaterJet unit lock the cover.

Figure 5 WaterJet cover-locking latches

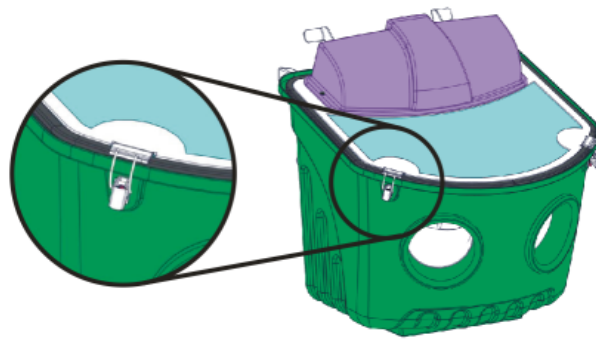

# Nozzle Selection and Flow Regulation

Two nozzles are available:

- spray nozzle
- jet nozzle

A flow regulator is supplied in some models, for controlling the water flow.

Figure 6 Nozzle selector valve and flow regulator

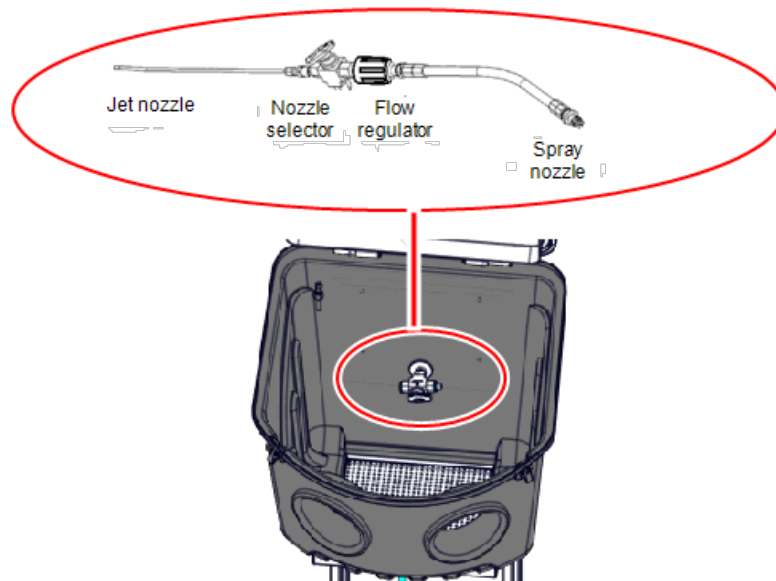

# Foot Pedal

The foot pedal activates the water pressure pump.

Figure 7 Foot pedal

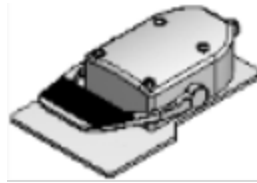

# Waste Filter

The Support material removed during the cleaning process collects in the waste filter at the bottom of the WaterJet unit. Remove and clean the waste filter regularly, preferably after each model-cleaning session.

Figure 8 Waste filter

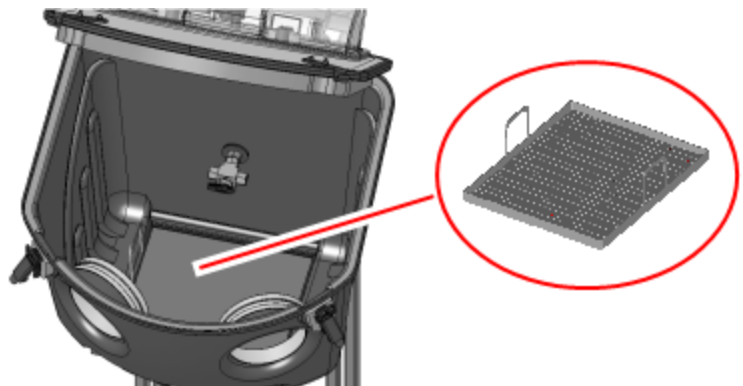

# Water Inlet

The high-pressure hose from the water pressure pump connects to the water inlet at the back of the unit.

Figure 9 Water inlet connection

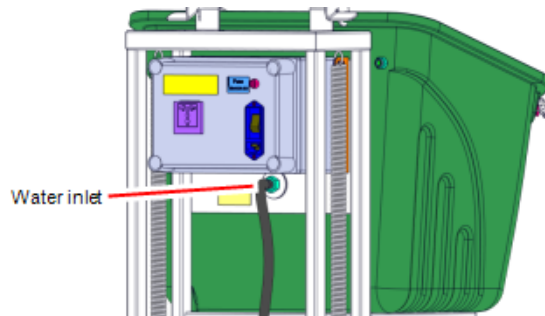



# 4

## Installation

<b>Mounting the WaterJet on the Stand</b> .....	<b>18</b>
Preparing the Base .....	18
Placing the WaterJet on the Counter Stand .....	19
Placing the WaterJet on the Floor Stand .....	20
<b>Leveling the WaterJet Unit</b> .....	<b>22</b>
<b>WaterJet Connections</b> .....	<b>23</b>
Connecting the Water Supply .....	24
Connecting the Drain Hose .....	25
Connecting the Power Cables .....	26

# Mounting the WaterJet on the Stand

You can place the WaterJet unit on the floor or on a raised surface, such as a table or a counter.

## Preparing the Base

Before assembling the WaterJet stand, connect the four feet to the base of the stand (see [Figure 10](#)).

### To connect the feet to the base:

1. Prepare—
  - a 17-mm open-end wrench
  - 4 feet with nuts (supplied)
2. Fasten a nut on each of the WaterJet feet.
3. Insert the feet into the base, through the holes.
4. Secure each of the feet to the base with another nut.
5. Tighten the top nuts.

Figure 10 Attaching the WaterJet feet

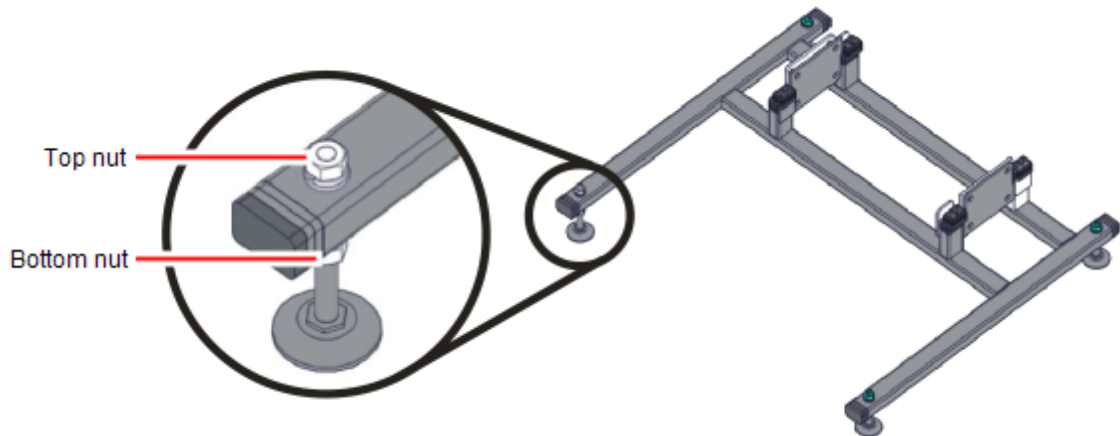

## Placing the WaterJet on the Counter Stand

### To attach the WaterJet on the counter stand:

1. Prepare—
  - an M6 Allen key
  - a 13-mm open-end wrench
  - 8 M8 Allen screws with nuts (supplied)
2. Place the WaterJet unit on the base (see Figure 11).
3. Make sure the matching attachment plates (on the unit and base) are flush, and that the holes are aligned.



#### Note:

There should be no space between the attachment plates (on the unit and on the base).

Figure 11 Attaching the counter stand

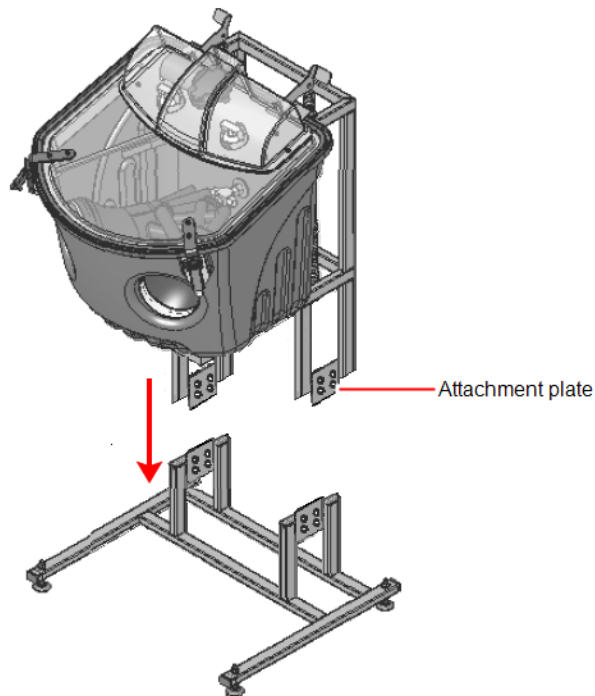

4. Insert the Allen screws into the holes in the attachment plates and secure with the nuts.

## Placing the WaterJet on the Floor Stand

### To assemble the floor stand:

1. Prepare—
  - an M6 Allen key
  - a 13-mm open-end wrench
  - 16 Allen screws and nuts (supplied)
2. Fit the stand extension onto the base (see Figure 12).
3. Make sure that—
  - the matching attachment plates (on the stand extension and base) are flush
  - the holes are aligned
  - the “INNER SIDE” label is facing the other side of the stand

Figure 12 Attaching the stand extensions

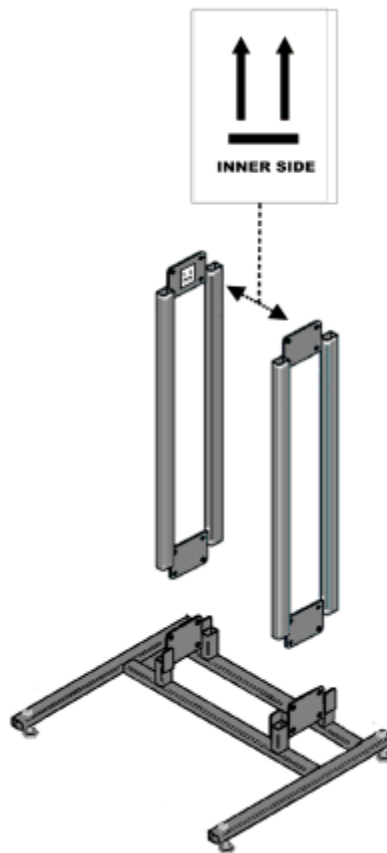

4. Insert the Allen screws into the holes in the attachment plates and secure with the nuts.
5. Repeat steps 1-3 for the other stand extension.

**To attach the WaterJet on the floor stand:**

1. Place the WaterJet unit on the floor stand (see Figure 13), making sure that the matching attachment plates (on the unit and stand extensions) are flush, and that the holes are aligned.

Figure 13 Attaching the WaterJet to the floor stand

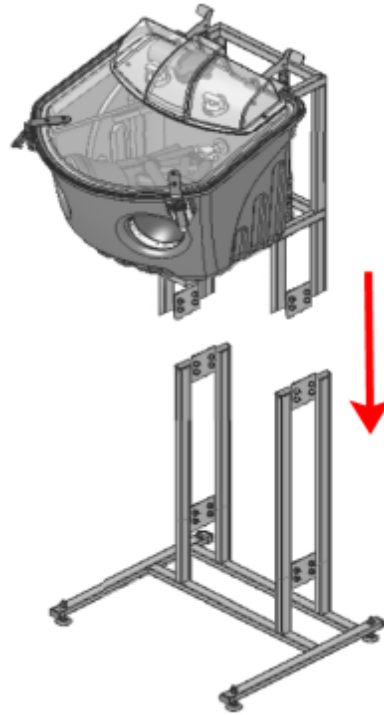

**Note:**

There should be no space between the attaching plates.

2. Insert the Allen screws into the holes in the attachment plates and secure with the nuts.

# Leveling the WaterJet Unit

The WaterJet unit should be level, with all four feet resting securely on the floor or counter.

## To level the unit:

1. Prepare—
  - a 17-mm open-end wrench
  - a spirit (bubble) level
2. Place the spirit level on the base of the WaterJet stand, front-to-back.
3. Loosen all of the top nuts that secure the feet.
4. Turn all of the bottom nuts until the stand is level.
5. Reposition the spirit level on the base, left-to-right.
6. Turn the bottom nuts until the stand is level.
7. Tighten the top nuts.

Figure 14 Leveling the WaterJet

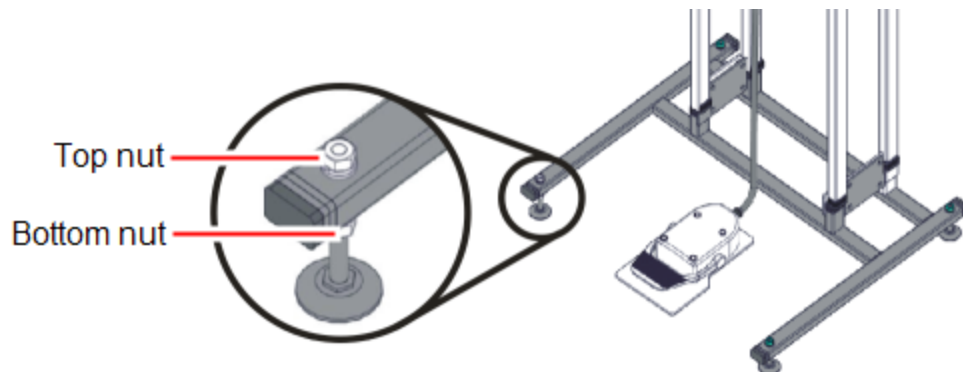

# WaterJet Connections

The following figure shows the WaterJet unit and the water pressure pump assembled and connected to the electrical and water supplies.

Figure 15 WaterJet connections

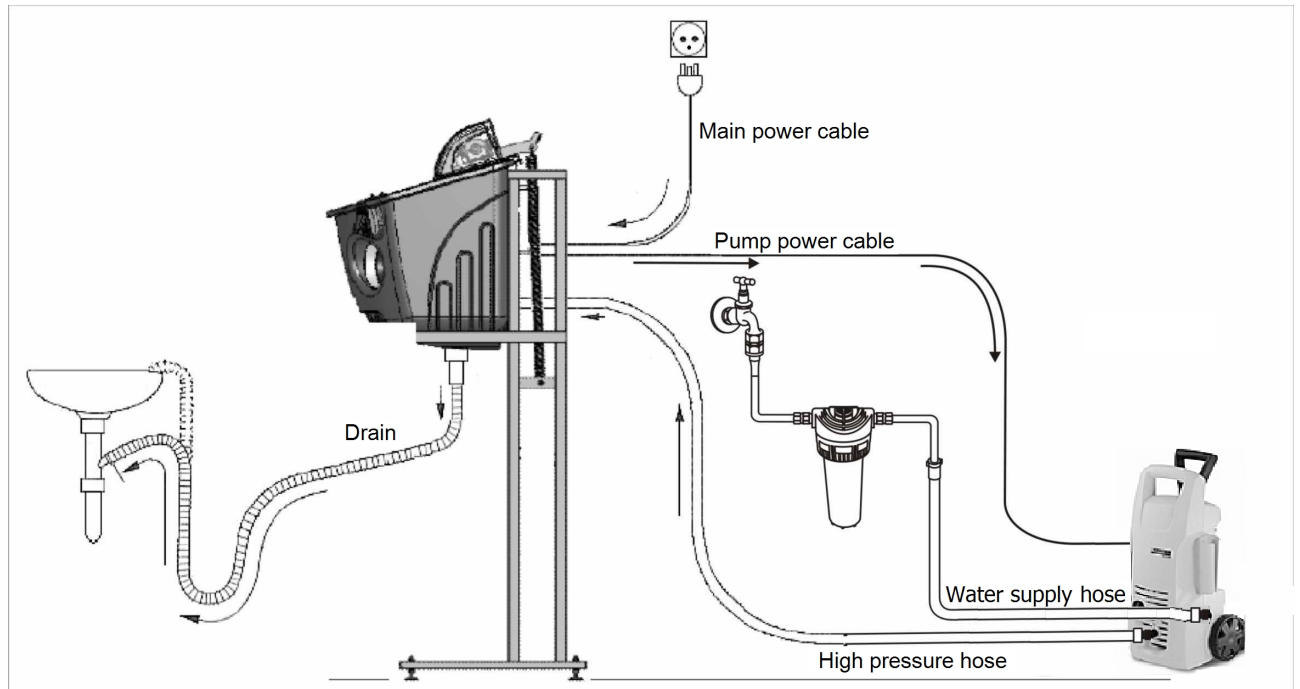

## Connecting the Water Supply

Before connecting the water supply, make sure that it meets the minimum requirements specified in the Site Preparation Guide.

To obtain the Site Preparation Guide, [click here](#) or contact your StratasyS representative.



### Caution:

Lack of water or insufficient water pressure can cause the pump to operate improperly, overheat or fail.

### To connect the water supply:

1. Remove the “washing machine” hose from the package.

Figure 16 “Washing machine” hose



2. Connect one end of the hose to the water inlet on the pump.

Figure 17 Pump water inlet





3. Connect the other end of the hose to a filtered cold water tap.

Figure 18 Water supply connections

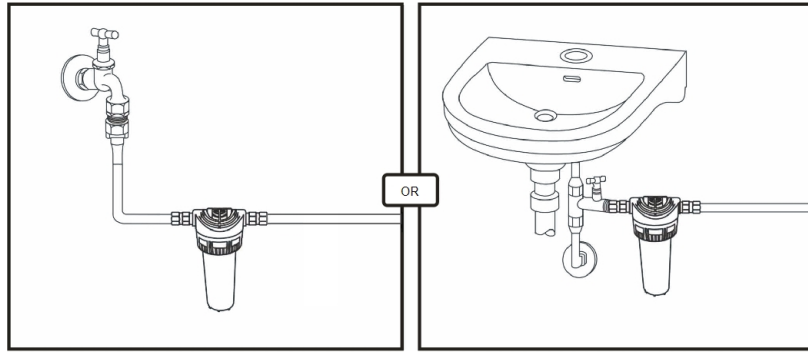

4. Connect the high pressure hose to the water outlet on the pump.

Figure 19 Pump water outlet

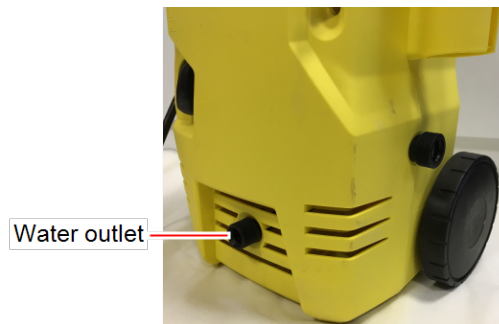

## Connecting the Drain Hose

### To connect the drain:

1. Connect the drain hose between the WaterJet outlet and the drain connection.
2. Insert the hose about 5 cm (2 in.) into the drain, to prevent the waste water from leaking.

Figure 20 Drain options

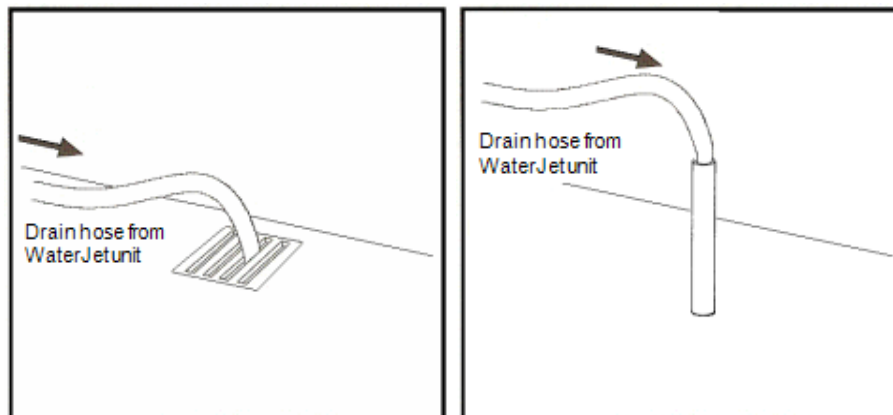

## Connecting the Power Cables

The power cable from the water pressure pump connects to the electrical box on the WaterJet unit. A power cable connects the WaterJet unit to the wall socket.



### Note:

The pump should not be connected directly to the wall socket. Therefore, a special plug is used to prevent you from doing so.

Figure 21 Pump power plug that connects to the electrical box

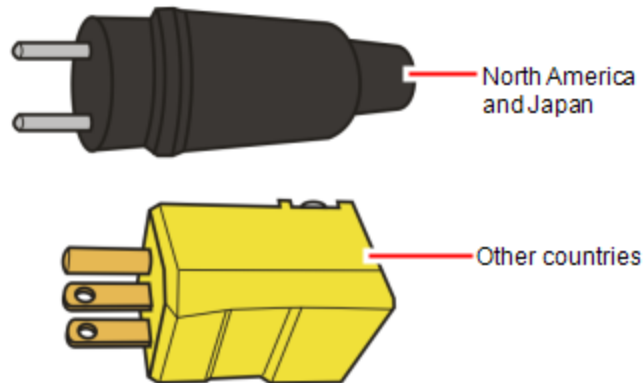

### To connect the power cables:

1. Prepare the main power cable that connects the WaterJet unit to the wall socket.
  - For North America and Japan, the power cable is supplied with the WaterJet unit.

Figure 22 Main power cable for North America and Japan



- For all other countries, an IEC 320 10A/100-230 V, C13 cable is supplied by the distributor or the customer.
2. Make sure that the pump is turned off.
  3. Connect the cable from the pump to the universal power socket on the electrical box (see Figure 4 on page 14).

4. Make sure the main power switch at the back of the WaterJet unit is turned off.



**Important:**

Leakage currents could cause serious electrical shock. Make sure that the wall outlet conforms with the requirements specified in the Site Preparation Guide.

5. Connect the main power cable from the electrical box to the wall socket.

# 5

## Cleaning Models

<b>Cleaning Process</b> .....	<b>29</b>
<b>Removing Excess Support Material by Hand</b> .....	<b>29</b>
<b>Capacity</b> .....	<b>29</b>
<b>Removing Support Material with the WaterJet</b> .....	<b>30</b>
Spray Nozzle .....	30
Jet Nozzle .....	30
Operating the WaterJet .....	31
After Using the WaterJet .....	32
<b>Removing Support Material with Sodium Hydroxide</b> .....	<b>32</b>

# Cleaning Process

Models can be cleaned using different methods, depending on the size of the model, how delicate it is, and the amount and location of the Support material.

## Removing Excess Support Material by Hand

Wear protective gloves and break away the excess Support material on the outside of the model. For delicate models, use a toothpick, pin or small brush after dipping the model in water.

## Capacity

The Objet WaterJet can clean models that have the following maximum dimensions:

Table 1 Maximum model size

W × H × D (cm)	W × H × D (in.)
30 × 25 × 20	11.8 × 9.8 × 7.9

# Removing Support Material with the WaterJet

For most models, the most efficient way to remove Support material is with the WaterJet.

## Spray Nozzle

The spray nozzle is suitable for large models without thin walls or fragile sections.



### Note:

The spray nozzle is not suitable for cleaning models made from Tango printing materials. Using it could leave noticeable marks on these models.

Figure 23 Model cleaning using the spray nozzle

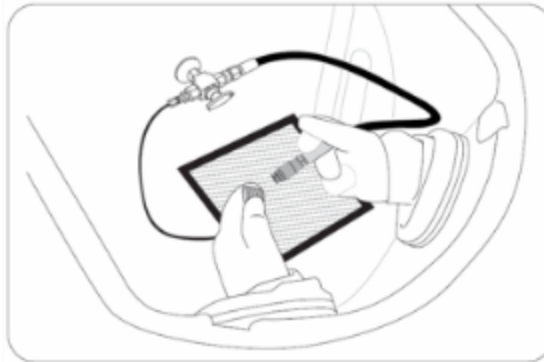

## Jet Nozzle

The jet nozzle is suitable for:

- delicate parts
- parts with thin walls or fragile areas
- clearing Support material from cavities, pipes, tubes and cylinders
- models made from Tango materials

Figure 24 Model cleaning using the jet nozzle



## Operating the WaterJet

### To operate the WaterJet:

1. Open the water supply source to the pump.
2. Turn on the main power switch at the back of the WaterJet.
3. Open the WaterJet cover.
4. Place a model in the WaterJet unit.
5. Close the cover and lock it with the latches (see "Cover Latches" on page 15).



#### **Warning: Jetting hazard**

The WaterJet stream can cause injury.  
Lock the WaterJet cover before operating it.



#### **Warning: Acoustic hazard**

Prolonged exposure to loud noise can cause hearing loss.  
Wear earplugs while operating the WaterJet unit.

6. Insert your hands into the built-in gloves in the WaterJet unit.
7. Select a suitable cleaning nozzle.
8. Using the foot pedal, activate the WaterJet to clean the model. If there is a flow regulator, use it to increase or decrease the flow.

Figure 25 Using the flow regulator



9. After removing the Support material, open the WaterJet cover and remove the model.

## After Using the WaterJet

1. Turn off the WaterJet.



**Note:**

The pressure pump is powered through the WaterJet electrical box. You do not need to turn it off.

2. Empty the waste filter.
3. Close the water supply tap to prevent leaks and damage to the water hose and connections.
4. Open the cover to allow the WaterJet interior to dry and to prevent corrosion of the wiper motor.

## Removing Support Material with Sodium Hydroxide

To remove thin layers of Support material or from hard-to-reach areas, and to give the model a smooth, clean finish, soak the model in a 1-percent solution of sodium hydroxide (NaOH, known as **caustic soda**).

The amount of time required to soak the model in the solution depends on how delicate it is and how much Support material needs to be removed, but it is typically between half-an-hour and several hours. In any case, you should remove as much Support material as possible before the treatment, and rinse the model thoroughly with the WaterJet afterwards.



**Warning: Toxic Hazard**

Caustic soda might cause chemical burns, scarring and blindness. Take adequate safety precautions; always use nitrile gloves when handling caustic soda and models soaked in it.



**Warning: Fire Hazard**

Mixing caustic soda with water creates heat that could ignite other materials. Never pour water onto caustic soda. Always add caustic soda to water. For more information, request the document, "Working with Alkaline Cleaning Solution" (DOC-08380) from your Stratasys representative.



# 6

## Maintenance

<b>Replacing a Lamp</b> .....	<b>34</b>
<b>Replacing the Wiper Fuse</b> .....	<b>36</b>
<b>Maintaining the Water Pressure Pump</b> .....	<b>37</b>
Maintenance .....	37
Troubleshooting .....	38

# Replacing a Lamp

If a lamp inside the WaterJet cover fails, replace it with a standard 24 volt, 15-watt halogen lamp.



## Warning: Hot Surface

The lamp might be hot. Wait until the lamp has cooled before handling it.

### To replace a lamp:

1. Turn off the power switch, on the electrical box.
2. Disconnect the power cable from the wall socket, and place it on a dry surface.



## Warning: Electrical Hazard

Contact with live circuits could cause serious electric shock. Do not continue before turning off the power switch and disconnecting the power cable from the wall socket.

3. Using a Phillips screwdriver, remove the two screws that secure the protective cover (see Figure 26).

Figure 26 Removing the protective cover

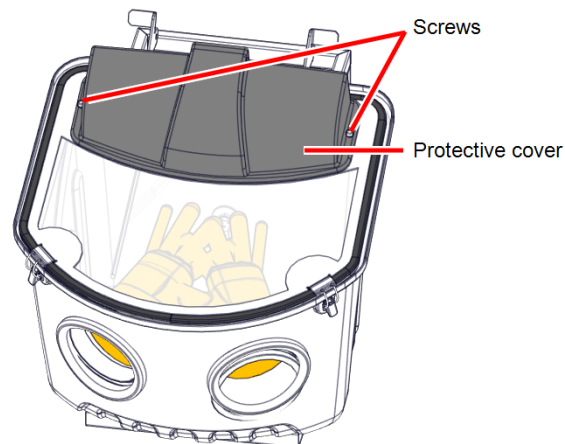

4. Remove the protective cover.

5. Remove the lamp holder (see Figure 27).

Figure 27 Lamp assembly

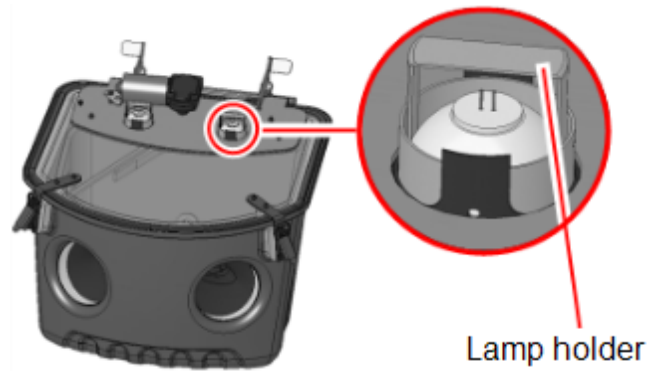

6. Remove the metal band securing the lamp and carefully move the lamp out of the lamp assembly.
7. Pull the faulty lamp out of the socket.
8. Grasp the new lamp with a clean cloth, and insert it into the socket.



**Caution:**

Do not touch the glass part of the new lamp with your fingers. Oil from your fingers can cause the lamp to explode.

9. Place the lamp in the lamp assembly and attach the metal band.
10. Insert the lamp holder.
11. Secure the protective cover. (If necessary, push the locking screws up from under the WaterJet cover.)

# Replacing the Wiper Fuse

If the wiper fuse fails, replace it with one that has the same rating (250V/3.5A/SB).

To replace the wiper fuse:

1. Turn off the power switch, on the electrical box.
2. Disconnect the power cable from the wall socket, and place it on a dry surface.



## Warning: Electrical Hazard

Contact with live circuits could cause serious electric shock. Do not continue before turning off the power switch and disconnecting the power cable from the wall socket.

3. Using a flat-head screwdriver, turn and remove the fuse holder from the electrical box.

Figure 28 Replacing the Wiper Fuse

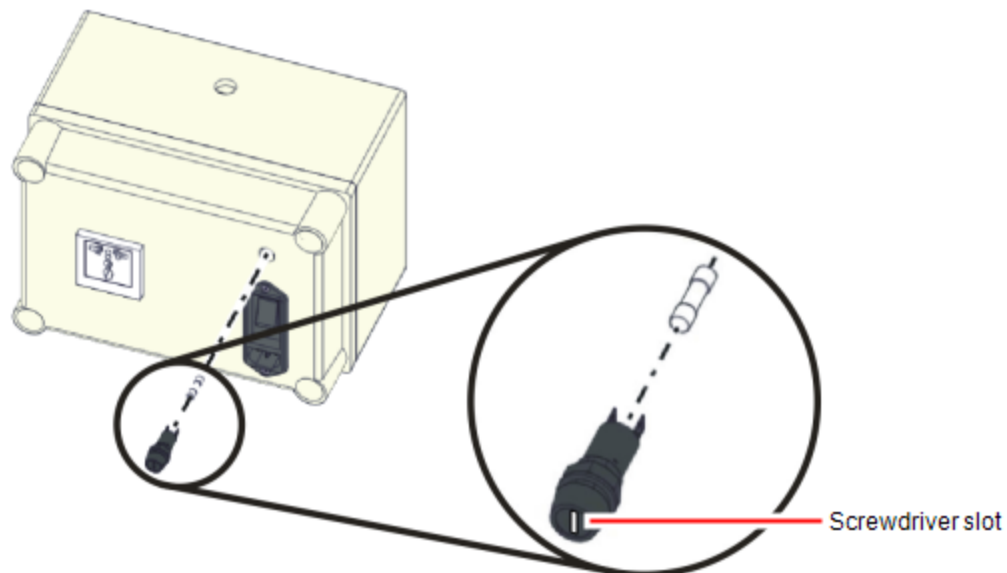

4. Remove the fuse from the fuse holder.
5. Check that the new fuse has the same rating as the replaced one.
6. Insert the new fuse into the fuse holder.
7. Insert the fuse holder into the electrical box and turn to secure.
8. Make sure that the electrical plug is dry, and connect it to the wall socket.
9. Turn on the power switch.
10. Operate the WaterJet and make sure that the wiper operates properly.

# Maintaining the Water Pressure Pump

## Maintenance

Perform the following maintenance checks at least once every six months.

### Water Pressure and Flow

1. Check that the water supply filter is not clogged.
2. Check that the pump filter is not clogged.

Figure 29 Pump filter

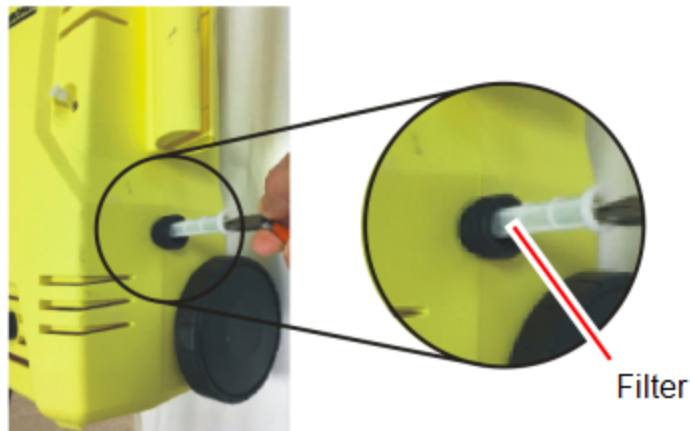

3. Check that the water tap is open fully.



### Caution:

Insufficient water flow/pressure can result in damage to the pump.

### Water Leaks

Check the pump, the hoses, and all connections.

- If water leaks from a hose connection, open it and replace the seal.
- If a connector leaks, replace the thread-seal tape, as follows:
  - a. Open the connector and remove the old thread-seal tape.
  - b. Wrap fresh thread-seal tape (for example, **PTFE** or **Teflon**<sup>®</sup> tape) on the thread of the connector.

Wrap thread-seal tape clockwise, in the direction of the thread, so that it doesn't unwrap when tightening the connection.
  - c. Close and tighten the connector.

## Troubleshooting

The following are typical issues and suggested solutions.

### **The pump turns off every 10 to 15 seconds.**

1. Detach the spray nozzle tip from the nozzle selector valve in the WaterJet and let the water run for about five minutes with the pump on.

This action removes air and dirt trapped in the water pressure pump and in the water supply hose.

2. Check that the nozzle tip is not blocked or damaged.
3. Re-attach the spray nozzle tip.

### **The pump stops working.**

- Reduced water flow might cause the pump to overheat and stop. Check that the tap is open fully and that the water supply and pump filters are not clogged.
- Check the main fuse and replace, if necessary.



[www.stratasys.com](http://www.stratasys.com)

---

**stratasys**<sup>®</sup>

THE 3D PRINTING SOLUTIONS COMPANY