

Type FB1300 & FB1400 Furnaces

OPERATION AND REPAIR MANUAL AND PARTS LIST SERIES 1256 & 1257

Model Numbers

FB1310M, FB1310M-26, FB1314M, FB1315M, FB1318M, FB1310M-33
FB1410M, FB1410M-26, FB1414M, FB1415M, FB1418M, FB1410M-33

Table of Contents

Safety Information	3
Important Information.....	3
Warnings	4
Introduction.....	5
Intended Use	5
General Usage.....	5
Principles of Operation	5
General Specifications	6
Declaration of Conformity	7
Unpacking	8
Installation	9
Site Selection.....	9
Electrical Connections	9
Operation	10
Power Switch	10
Cycle Light.....	10
Door Safety Switch	10
Single Setpoint Controller	10
Basic Operation	11
Buttons and Indicators	11
To View or Change the Setpoint	12
To View the Display Units	12
To View the % Output Power.....	12
Controller Parameters	12
Alarms	13
Sensor Break Protection	14
Overt Temperature Protection (OTP).....	14
Tuning	14
Furnace Loading	16
Preventive Maintenance.....	17
Troubleshooting	18
Maintenance and Servicing	19
To Replace Heating Element.....	19
To Replace Thermocouple.....	22
To Replace Insulation	23
To Replace Door Switches	25
To Replace Solid State Relay	26
To Replace PC Board (Controller).....	26
Wiring Diagram.....	27
Exploded View	28
Replacement Parts List	30
Ordering Procedures	31
One Year Limited Warranty	32

Safety Information

Alert Signals



Warning

Warnings alert you to a possibility of personal injury.



Caution

Cautions alert you to a possibility of damage to the equipment.



Note

Notes alert you to pertinent facts and conditions.



Hot Surface

Hot surfaces alert you to a possibility of personal injury if you come in contact with a surface during use or for a period of time after use.

Important Information

This manual contains important operating and safety information. You must carefully read and understand the contents of this manual prior to the use of this equipment.

Your Thermolyne FB1300 Model or FB1400 Model Furnace has been designed with function, reliability, and safety in mind. It is your responsibility to install it in conformance with local electrical codes. For safe operation, please pay attention to the alert signals throughout the manual.

Warnings

To avoid electrical shock, this furnace must:

1. Use a properly grounded electrical outlet of correct voltage and current handling capacity.
2. Be disconnected from the power supply before servicing.
3. Have the door switch operating properly.

To avoid burns:

1. “Caution: Hot Surface. Avoid Contact.” Do not touch the exterior or interior surfaces of the furnace during use or for a period of time after use.

To avoid personal injury:

1. Do not use in the presence of flammable or combustible materials — fire or explosion may result. This device contains components which may ignite such material.
2. Refer servicing to qualified personnel.

SAFETY INFORMATION

Please note the following WARNINGS:

WARNING

This warning is presented for compliance with California Proposition 65 and other regulatory agencies and only applies to the insulation in this product. This product contains refractory ceramic, refractory ceramic fiber or fiberglass insulation, which can produce respirable dust or fibers during disassembly. Dust or fibers can cause irritation and can aggravate preexisting respiratory diseases. Refractory ceramic and refractory ceramic fibers (after reaching 1000°C) contain crystalline silica, which can cause lung damage (silicosis). The International Agency for Research on Cancer (IARC) has classified refractory ceramic fiber and fiberglass as possibly carcinogenic (Group 2B), and crystalline silica as carcinogenic to humans (Group 1).

The insulating materials can be located in the door, the hearth collar, in the chamber of the product or under the hot plate top. Tests performed by the manufacturer indicate that there is no risk of exposure to dust or respirable fibers resulting from operation of this product under normal conditions. However, there may be a risk of exposure to respirable dust or fibers when repairing or maintaining the insulating materials, or when otherwise disturbing them in a manner which causes release of dust or fibers. By using proper handling procedures and protective equipment you can work safely with these insulating materials and minimize any exposure. Refer to the appropriate Material Safety Data Sheets (MSDS) for information regarding proper handling and recommended protective equipment. For additional MSDS copies, or additional information concerning the handling of refractory ceramic products, please contact the Customer Service Department at Barnstead International at 1-800-553-0039.

Introduction

Intended Use

The FB1300 Model and FB1400 Model furnaces are general purpose laboratory and heat treating furnaces. For optimum element life, observe the following temperature ranges: 100°C (212°F) to 982°C (1800°F) for continuous use, or from 982°C (1800°F) to 1100°C (2012°F) for intermittent use. Continuous use is operating the furnace for more than three straight hours, and intermittent use is operating the furnace for less than three hours.

The unit consists of a heating chamber and a digital controller. See Figure 1 for the overall shape and general features of the unit.

General Usage

Do not use this product for anything other than its intended usage.

Principles of Operation

The furnace chamber is heated by a single three section resistant heater which is embedded in a refractory material. The chamber is insulated with a ceramic fiber insulation. The temperature is controlled by an electronic control. The temperature is measured by a thermocouple and is registered on a digital display. For safety, door switches are incorporated to remove power from the heating elements when the door is opened. The furnace is supported by the control section which also houses the electrical connections.

General Specifications

FB1300 Models

Dimensions: (handle not included)

Chamber: 4" W x 3.75" H x 4.5" D (10.2 x 9.5 x 11.4 cm)

Overall : 7.9" W x 13.8" H x 8.5" D (20.0 x 34.9 x 21.6 cm)

Weight: 15.7 lb. (7.1 kg)

Electrical Ratings:

<u>Model #</u>	<u>Volts</u>	<u>Amps</u>	<u>Watts</u>	<u>Phase</u>	<u>Frequency</u>
FB1310M	220-240	4.4	1060	1	50/60
FB1310M-26	220-240	4.4	1060	1	50/60
FB1310M-33	220-240	4.4	1060	1	50/60
FB1314M	100	10.6	1060	1	50/60
FB1315M	120	8.9	1060	1	50/60
FB1318M	208	5.1	1060	1	50/60

Temperature: Operating Range (continuous): 982°C; (intermittent): 1100°C.

Environmental Conditions:

Operating: 17°C - 27°C; 20% - 80% relative humidity, non-condensing. Installation

Category II (over-voltage) in accordance with IEC 664. Pollution Degree 2 in accordance with IEC 664. Altitude limit: 2,000 meters.

Storage: -25°C - 65°C; 20% - 80% relative humidity.

FB1400 Models

Dimensions: (handle not included)

Chamber: 5.00" W x 4.25" H x 6.00" D (12.7 x 10.8 x 15.2 cm)

Overall: 9.7" W x 15.8" H x 11.1" D (24.6 x 39.0 x 28.3 cm)

Weight: 23 lb. (10.4 kg)

Electrical Ratings:

<u>Model #</u>	<u>Volts</u>	<u>Amps</u>	<u>Watts</u>	<u>Phase</u>	<u>Frequency</u>
FB1410M	220-240	6.3	1520	1	50/60
FB1410M-26	220-240	6.3	1520	1	50/60
FB1410M-33	220-240	6.3	1520	1	50/60
FB1414M	100	14.5	1520	1	50/60
FB1415M	120	12	1450	1	50/60
FB1418M	208	7.3	1520	1	50/60

Temperature: Operating Range (continuous): 982°C; (intermittent): 1100°C.

Environmental Conditions:

Operating: 17°C - 27°C; 20% - 80% relative humidity, non-condensing. Installation

Category II (over-voltage) in accordance with IEC 664. Pollution Degree 2 in accordance with IEC 664. Altitude limit: 2,000 meters.

Storage: -25°C - 65°C; 20% - 80% relative humidity.

Declaration of Conformity

Barnstead International hereby declares under its sole responsibility that this product conforms with the technical requirements of the following standards (-33 models only):

EMC: EN 50081-1 Generic Emission Standard;
EN 50082-1 Generic Immunity Standard.
Safety: EN 1010-1-92 Safety requirements for
electrical equipment for
measurement, control and
laboratory use; Part I:
General Requirements
EN 1010-2-010 Part II: Particular requirements
for laboratory equipment for the
heating of materials

per the provisions of the Electromagnetic Compatibility Directive 89/336/EEC, as amended by 92/31/EEC and 93/68/EEC, and per the provisions of the Low Voltage Directive 73/23/EEC, as amended by 93/68/EEC.

The authorized representative located within the European Community is:

Electrothermal Engineering, Ltd.
419 Sutton Road
Southend On Sea
Essex SS2 5PH
United Kingdom

Copies of the Declaration of Conformity are available upon request.

Unpacking

1. Visually check for any physical damage to the shipping container.
2. Inspect the equipment surfaces that are adjacent to any damaged area.
3. Open the furnace door and remove the packing material from inside the furnace chamber.
4. Vacuum the chamber prior to use to remove the insulation dust due to shipment.
5. Retain the original packaging material if reshipment is foreseen or required.

Installation



Caution

Be sure ambient temperature does not exceed 40°C (104°F). The recommended ambient temperature is 17°C - 27°C. Ambients above this level may result in damage to the controller.



Caution

Allow at least six inches of space between the furnace and any combustible surface. This permits the heat from the furnace case to escape so as not to create a possible fire hazard.



Warning

To avoid electrical shock, this furnace must always use a properly grounded outlet of correct voltage and current handling capacity.

Site Selection

Install furnace on a sturdy surface and allow adequate space for ventilation.

Electrical Connections

The electrical ratings are located on the specification plate on the back of the furnace. Consult Barnstead International if your electrical service is different than those listed on the specification plate. Be sure the front power switch is in the OFF position before connecting the furnace to your electrical supply.

Operation, All Modes



Warning

To avoid personal injury do not use in the presence of flammable or combustible chemicals; fire or explosion may result. This device contains components which may ignite such materials.



Hot Surface

Caution: Avoid Contact. To avoid burns, this furnace must not be touched on the exterior or interior surfaces during use or for a period of time after use.



Warning

Always wear safety glasses or a safety shield and high temperature gloves when loading or unloading the furnace. Long sleeved, fire retardant clothing and a fire retardant apron is also recommended.



Warning

To avoid electrical shock, the door safety switch must be operating properly.

Power Switch

Both the ON/OFF power switch and the digital display will illuminate when power is switched ON. The furnace will begin to heat to the controller's current setpoint. (See the instructions for your type of controller for information on checking and setting the setpoint.)

Cycle Light

The amber cycle light will illuminate whenever the power is being applied to the heating elements. The cycle light will turn on and off as the furnace reaches the setpoint.

Door Safety Switch

The door safety switch removes power from the heating elements when the door is opened. Open and close the door a few times; note that the amber CYCLE light will switch off when the door is opened. If this condition is not true, consult the Troubleshooting section before proceeding. This check must be done when the furnace is heating and the cycle light is illuminated.

Single Setpoint Controller

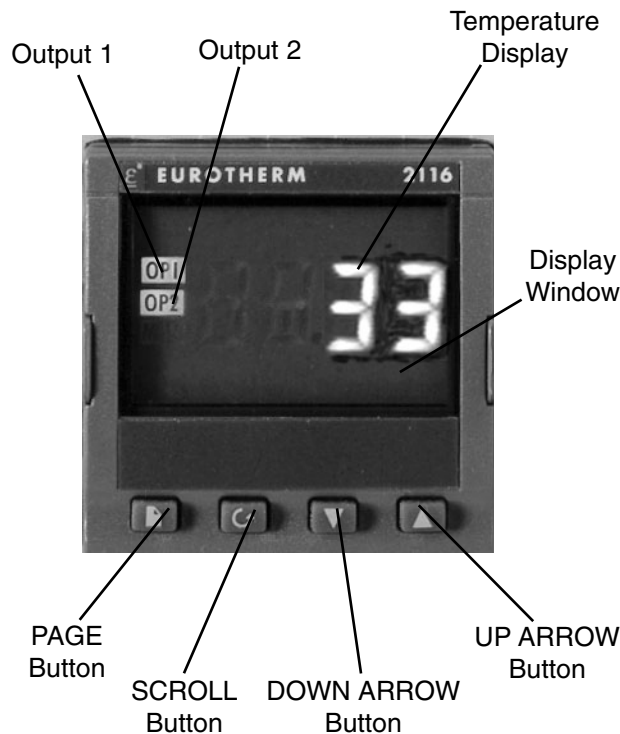

Single Setpoint Models



Note

If at any time you want to return to the HOME DISPLAY, simultaneously press the PAGE and SCROLL buttons.

The **single setpoint model** furnace controller is a single setpoint controller which provides a single digital display to indicate the current chamber temperature or setpoint temperature. This temperature controller features sensor break protection and self-tuning capability.

Basic Operation

When the controller is turned ON it will perform a short self-test and then display the measured value (process value) in the HOME DISPLAY.

Buttons and Indicators

OP1 (Output 1): Illuminates when the logic output is ON.

OP2 (Output 2): Illuminates when the relay output is ON (will go out during an alarm situation).

PAGE button: Allows you to select a new list of parameters.

SCROLL button: Allows you to select a parameter within a list of parameters.

DOWN button: Allows you to decrease a value.

UP button: Allows you to increase a value.

To View or Change the Setpoint

To view the setpoint, press and release the UP or DOWN buttons. If you want to change the setpoint, continue pressing until the

desired setpoint value is displayed and then release the button. A few seconds after the button is released, the controller will accept the new value and revert to the HOME DISPLAY.

To View the Display Units

From the HOME DISPLAY press the SCROLL button. The display will show the temperature units in °C/F/K and then return to the HOME DISPLAY. (Call Customer Service if you require a different temperature unit.)

To View the % Output Power

From the HOME DISPLAY press the SCROLL button twice. Press and release the UP or DOWN button to view the % output power. This value is a read-only value and cannot be changed.

Controller Parameters

Home display

°C: Temperature units in Celsius. Temperature units can not be changed without entering the configuration. Contact Customer Service if a different temperature unit is required.

OP: % output power demand.

IdHi: Deviation high alarm.

Al List

IdHi: Deviation high alarm.

Atun List

tunE: One-shot autotune enable.

Pid List

Pb: Proportional band (in display units).

ti: Integral time in seconds.

td: Derivative time in seconds.

ACCS List Code: Access code (Code needed to enter or change the other configuration parameters which are not normally accessible.) Not accessible.

Alarms

The controller will flash an alarm message in the home display if an alarm condition is detected.

2FSH: Measured value full scale high alarm.

IdHi: Measured value deviation high alarm.

S.br: Sensor break: check that sensor is connected correctly.

L.br: Loop break: check that the heating circuits are working properly.

Ld.F: Heater Circuit fault: indication of either an open or short solid state relay, a blown fuse, missing supply or open circuit heater.



Note

The following alarm messages are factory default settings and may vary if you have changed the configuration of your controller:

IDHi: = 50°C

2FSH: = 1125°C

Sensor Break Protection

This controller provides sensor break protection in the event the thermocouple opens. If an open thermocouple condition occurs, the digital display will blink “S.br” and the power to the heating element will be shut OFF (Cycle light will extinguish).

Over-Temperature Protection (OTP)

The OTP will be in effect during any alarm condition when the temperature of the furnace has deviated beyond the limit. The “Deviation High” alarm is the only alarm value which can be changed. To change it, press the SCROLL button until “IdHi” appears on the display. Press the UP or DOWN button to select the OTP value you desire. We recommend a value of 20° above your working temperature to provide protection for your workload.

Tuning

This controller incorporates a self-tuning feature which determines the optimum control parameters for the best temperature accuracy with your load and setpoint. Use this feature the first time you use your furnace and each time you change either your setpoint or the type of load you are heating.

Barnstead|Thermolyne recommends you use this feature to provide the best temperature accuracy the controller can attain. To use the tuning feature:

1. Adjust the setpoint to your desired value.
2. Press the PAGE button until display reads, “Atun.”



Note

Furnace must be at ambient temperature before starting a tune.

3. Press the SCROLL button. Display will read, “tunE.”
4. Press the UP or DOWN button to select, “on.”
5. Simultaneously press the PAGE and SCROLL buttons to return to the HOME DISPLAY. The display will alternately flash between “tunE” and the HOME DISPLAY while tuning is in progress.
6. The controller will then turn the heating on and off to induce an oscillation. When the measured value reaches the required setpoint the first cycle will end.
7. Tuning will be complete after two oscillation cycles and then the tuner will turn itself off.
8. Normal control function will resume after the controller calculates tuning parameters.



Note

Tune has completed when “tunE” stops flashing on display.

Furnace Loading



Caution

Do not overload your furnace chamber or allow the load to touch the thermocouple. If the load is to be heated uniformly, it should not occupy more than two-thirds of any dimension of the chamber. Failure to observe these cautions could result in damage to furnace components and/or load.

- For best results of furnace loading, use less than two-thirds of any dimension of the chamber. Maintain a 3/4" clearance between the load and the sides of the chamber.
- If you are heating a number of small parts, spread them throughout the middle two thirds of the chamber.
- Keep objects away from thermocouple.
- Raise your load up off the furnace floor with small pieces of ceramic or a hearth plate to promote even heating.
- Use insulated tongs and mittens when loading and unloading furnace.
- Always wear safety glasses.

Preventive Maintenance

**Warning**

Before using any cleaning or decontamination method except those recommended by Barnstead International, users should check with Barnstead International that the proposed method will not damage the equipment.

**Warning**

Disconnect the furnace from power supply before cleaning.

**Warning**

Opening the door for an extended period of time will cause the painted surfaces above the door to be discolored or burnt.

Contamination is a major cause of element failure, therefore, when possible, remove the fume forming material before heating (e.g., cleaning cutting oil from tool steel).

The resistance wire is high-grade nickel-chromium. Some chemicals, notably sulphur, halogens, and cyanides, attack this wire at high temperatures, so avoid spilling these chemicals in the furnace or heating them any hotter than necessary. The refractory cement helps to protect the wire, but will not completely immunize it from damage.

All heating elements must be considered expendable, and replacement is expected; however, reasonable care in their use will greatly extend the service they will give. As the manufacturer has no control over the use or care of the elements, no specific service guarantee can be made.

Housekeeping is vital to your electric furnace—KEEP IT CLEAN! Run your furnace up to 871°C (1600°F) empty occasionally to burn off the contamination that may exist on the insulation and elements. Run for approximately two hours with the door slightly open. See warning.

Element life is reduced somewhat by repeated heating and cooling. If the furnace is to be used again within a few hours, it is best to keep it at the operating temperature or at a reduced level such as 260°C (500°F).

During normal use, the thermocouple in your furnace can become oxidized and cause inaccurate readings; therefore, we suggest that if you regularly use your furnace you should change your thermocouple once every six months to assure the accuracy of your controller readings.

Clean by wiping the outside case of the unit with a damp cloth and mild soap solution.

Troubleshooting

Problem	Possible Causes	Corrective Action
The furnace does not heat (CYCLE light does not illuminate).	<p>No power.</p> <p>Defective electrical hookup.</p> <p>Thermocouple has oxidized and opened the circuit. (Open thermocouple is indicated on the display as a temperature of 0-5 degrees).</p> <p>Fuse(s) blown</p> <p>Controller malfunction.</p> <p>Door switches malfunction.</p> <p>Defective solid state relay.</p>	<p>Check power source and fuses or breakers. Repair electrical hookup.</p> <p>Replace thermocouple.</p> <p>Replace fuse(s).</p> <p>Replace controller.</p> <p>Re-align or replace door safety switches.</p> <p>Replace output relay.</p>
Power is not cut to heating elements when the door is open.	Door switches are not functioning	Re-align or replace door switches.
Slow heatup.	<p>Low line voltage.</p> <p>Heavy load in chamber.</p> <p>Wrong heating element.</p>	<p>Install line of sufficient size and proper voltage. (Isolate furnace from other electrical loads.)</p> <p>Lighten load in chamber.</p> <p>Install proper element.</p>
Repeated element burnout.	<p>Overheating furnace.</p> <p>Heating harmful materials.</p> <p>Contamination present from pervious burnout.</p>	<p>Keep furnace under maximum temperature.</p> <p>Enclose material in container. Clean up spills in and on chamber. Ventilate chamber by opening door slightly when heating known harmful reagents.</p> <p>Replace insulation material.</p>
Inaccurate temperature readout.	<p>Oxidized or contaminated thermocouple.</p> <p>Poor thermocouple connection.</p> <p>Improper loading procedures.</p> <p>Poor ventilation of base.</p> <p>Thermocouple connections reversed. (Indicated by downscaling of temperature on display.)</p> <p>Controller malfunction.</p>	<p>Replace thermocouple.</p> <p>Tighten connections.</p> <p>Use proper loading procedures.</p> <p>Clear area around furnace base.</p> <p>Reconnect thermocouple correctly.</p> <p>Replace controller.</p>

Maintenance and Servicing



Warning

Disconnect the furnace from the power supply before servicing. Refer servicing to qualified personnel.



Note

Perform only maintenance described in this manual. Contact an authorized dealer or our factory for parts and assistance.



Note

It is seldom necessary to disconnect the thermocouple from the controller if the thermocouple is in good condition.

To Replace Heating Element

1. Set the furnace on its top. (See Figure 3). Remove thermocouple cover. (If equipped.)
2. Remove screw and clamp holding thermocouple, then grasp the thermocouple at the bend where it enters the furnace chamber and pull straight back. Retain porcelain insulator.
3. When the thermocouple tip is clear of the furnace back, bend it out of the way.
4. Remove the screws holding the steel back plate to the case.
5. Remove the steel back plate.

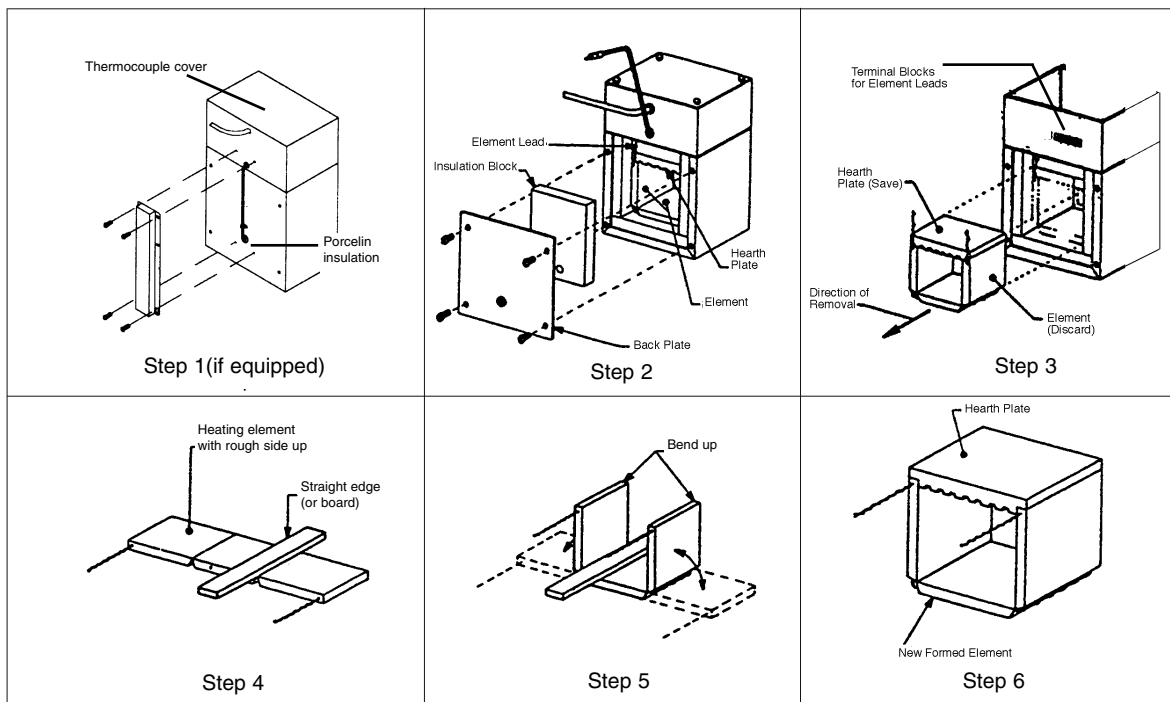

Figure 3: Replacement of a Heating Element

6. Remove the back insulation block by opening the door and gently pushing it out. Support this insulation block while removing it, as it is quite soft and easily crumbled at the edges.
7. Remove bottom cover to obtain access to terminals.

These steps will expose the heating element leads and insulating bushings in the bottom plate of the furnace.



Note

The hearth plate contains no heating coil, and may be saved for re-installation if it is in good condition. The hearth plate is replaceable independent of the heating element.

8. Cut the element leads between the element and the terminal block. (There are two leads.) The element and hearth plate unit may now be removed by pushing it straight back out of the furnace. Use care not to damage the chamber insulation when removing the hearth plate and element as it can be reused if it has not been contaminated.
9. Remove the old element lead wire and power wires from the terminal block, and save the sleeving for re-installation on the new element leads. Sleeving must be replaced if cracked or brittle!
10. New elements are shipped flat to protect them from damage in shipment, and to save space in storage. They must be formed before installation.
11. Place the element on a flat surface with the rough side up. Place a board or other straight edge along one row of notches.
12. Gently bend the element along the straight edge. The refractory cement will break along the row of notches.

Make the bend 90°, avoiding excessive bending. (The element wires will be exposed at the corner thus formed. This will not affect its life or performance.)

13. Bend the other side of the element.
14. Place the hearth plate across the open end of the “U” shaped element.
15. Slide the element and hearth plate unit into the chamber, pushing it firmly against the hearth collar. Use care not to damage the soft insulation. Remove any crumbs of insulation that may get between the unit and the hearth collar.
16. Thread the element leads through the ceramic bushings. Bend the leads so they lie close to the refractory plate and the bottom insulation block. (The easiest and safest way to do this is to press the wire flat with a stick or blunt pusher. Do not use a sharp object or nick the wire.)
17. Replace the sleeving and bend the lead 3/4 turn around the terminal screw. Cut off the excess wire. Replace power wires on top of element lead wires and tighten screw. Do not cross the wire over itself around the terminal; this makes it difficult to keep the connection tight and prevents good electrical contact. If you have excess wire, cut it off. Make sure element lead wires are not touching any other wires.
18. Replace the back insulation block and back plate.
19. Examine the thermocouple, and, if it is good, reinsert it into the chamber. It should extend



Note

Nicking or damaging the element leads will cause premature element failure.

about 1-1/2" into the chamber. Make sure porcelain insulator is in place for the thermocouple to pass through on the steel back plate. Replace clamp and screw. (Excessive scaling, pitting, or cracks are some indications that the thermocouple may need to be replaced.)

20. Replace bottom cover of control unit.
21. Replace thermocouple cover.
22. If replacement of back insulation is necessary, carefully redrill hole for thermocouple, using back cover as guide.
23. Reconnect furnace to power supply.
24. Test operation of furnace.



Warning

Disconnect the furnace from the power supply before servicing.



Note

If the thermocouple touches metal, this could short out the signal, causing the control to display room temperature. This could cause the furnace temperature to run away, possibly damaging furnace components.

To Replace Thermocouple

1. Set furnace on its top.
2. Remove thermocouple cover. (If equipped.)
3. Remove screw and clamp holding the thermocouple, then grasp the thermocouple at the bend where it enters the chamber and pull it straight back from the furnace. Retain porcelain insulator.
4. Remove bottom cover.
5. Disconnect the thermocouple from the terminal block by removing the screws on the terminals. Pull the thermocouple through the hole in the furnace base and discard.
6. Insert the new thermocouple into the back of the furnace chamber. Make sure the porcelain insulator extends through the steel back plate to prevent the lead wires from touching metal.

7. Thread the thermocouple through the hole in the base which has a nylon insulator, replace clamp and screw.
8. Bend the thermocouple sharply toward terminal block.
9. Secure the two yellow wires marked "+" together on the terminal block. Secure the two red wires "-" together on the adjacent terminal. Make sure connections are secure to terminal block.



Note

If the control temperature display moves downward, the thermocouple leads are reversed.

A polarity test of the thermocouple and lead wire is easily made with the use of a magnet. On chromel alumel thermocouples and lead wire, the non-magnetic wire is positive (+) and the magnetic wire is negative (-).

10. Replace bottom plate.
11. Replace thermocouple cover. (If equipped.)
12. Reconnect furnace to power supply.
13. Test operation of furnace.

To Replace Insulation

1. Remove thermocouple cover. (If equipped.)
2. Set furnace on its top and remove screw and clamp securing thermocouple, then grasp thermocouple and remove by pulling it straight back. Retain porcelain insulator.
3. Remove back plate.
4. Remove bottom cover.
5. Disconnect the element leads from terminal block.



Warning

Disconnect furnace from power supply before servicing.



Note

Identify or mark wires disconnected to ensure proper placement and connection when reinstalling.

6. Disconnect thermocouple leads from terminal block.
7. Remove four nuts holding control section to furnace chamber.
8. Remove the ground nut.
9. Remove the control section from the furnace chamber. Remove plates, screws, spacers and nuts. Be sure to note how plates are assembled together for reassembly.
10. Remove back piece of insulation by opening door and pushing it out gently.
11. Remove bottom piece of insulation by lifting it out.
12. Remove element and hearth plate by pulling it straight back out of the furnace chamber. (Be careful not to damage elements.)
13. Remove side insulating pieces.
14. To remove top insulating piece and hearth collar, position the furnace on its side. Remove both objects from furnace.
15. Reposition furnace on its top. Reinsert new hearth collar and the new top piece of insulation. Insert the new side pieces of insulation last.
16. Reinsert element and hearth plate unit into the chamber, pushing it firmly against the hearth collar. (Be careful not to damage insulation.)
17. Reinsert new bottom piece of insulation over hearth plate. (Element leads and ceramic bushings should be exposed above insulation bottom piece.)

18. Thread the element leads and ceramic bushings through the bottom plate. Bend the leads so they lie close to the refractory plate and the bottom insulation block. (The easiest and safest way to do this is to press the wire flat with a stick or blunt pusher. Do not use a sharp object or nick the wire.) Secure plate to furnace chamber.
19. Reverse steps 1-9 to reassemble furnace.

To Replace Door Switches

1. Place furnace upside down and remove bottom cover.
2. Disconnect wires from door switches. Identify or mark wires disconnected from door switches to ensure proper placement and connection when reinstalling.
3. Remove two screws and nuts from door switches and slide door switches out.
4. Install new door switches to bracket. Place furnace in an upright position. Adjust door switches until a click is heard from the switches, when furnace door is approximately 2" from being completely closed. Secure door switches to bracket.
5. Place furnace upside down. Reconnect the wires to new door switches.
6. Replace bottom cover and place furnace upright.
7. Reconnect furnace to power supply.
8. Test operation of door switches as described in step 4.



Warning

Disconnect furnace from power supply before servicing.



Warning

Disconnect furnace from power supply before servicing.



Warning

Disconnect furnace from power supply before servicing.

To Replace Solid State Relay

1. Place furnace upside down and remove the bottom cover.
2. Disconnect the wires from the solid state relay. Identify or mark the wires disconnected to ensure proper placement and connection when re-installing.
3. Remove solid state relay from bottom cover. Note placement of solid state relay.
4. Install new solid state relay and reconnect wires.
5. Replace bottom cover and place furnace upright.
6. Reconnect furnace to power supply.

To Replace Controller

1. Place furnace upside down and remove bottom cover.
2. Disconnect wires from the controller. Identify or mark wires disconnected to ensure proper placement and connection when re-installing.
3. Remove the controller from bottom cover.
4. Install new controller and secure.
5. Reconnect wires identified in step 3 to new controller.
6. Replace bottom cover and place furnace upright.
7. Reconnect furnace to power supply.

Wiring Diagrams

DIAGRAM COMPONENT LIST

REF. NO.	DESCRIPTION	MODEL NO. AND OUR PART NO.(S)					
		FB1410M	FB1410M-26	FB1410M-33	FB1414M	FB1415M	FB1418M
CN1	CONTROL	CN71X81	CN71X81	CN71X101	CN71X81	CN71X81	CN71X81
DS1	PILOT LIGHT	PLX82	PLX82	PLX82	PLX76	PLX76	PLX82
F1	FUSE	FZX30	FZX30	FZX30	FZX29	2-58147	FZX30
F2	FUSE	FZX30	FZX30	FZX30	FZX29	2-58147	FZX30
FL1	CAPACITOR			CAX98			
H1	HEATING ELEMENT	EL48X2	EL48X2	EL48X2	EL186X2	EL48X1	EL48X3
RY1	RELAY, SOLID STATE	RXX34	RXX34	RXX34	RXX34	RXX34	RXX34
S1	SWITCH, POWER	SWX144	SWX144	SWX144	SWX143	SWX143	SWX144
S2	SWITCH, DOOR	SWX163	SWX163	SWX163	SWX163	SWX163	SWX163
S3	SWITCH, DOOR	SWX163	SWX163	SWX163	SWX163	SWX163	SWX163
TB1	TERMINAL BLOCK	TRX96	TRX96	TRX96	TRX96	TRX96	TRX96
TB2	TERMINAL BLOCK	TRX136	TRX136	TRX136	TRX136	TRX136	TRX136
TC1	THERMOCOUPLE	TC746X1A	TC746X1A	TC746X1A	TC746X1A	TC746X1A	TC746X1A

FB 1400 models

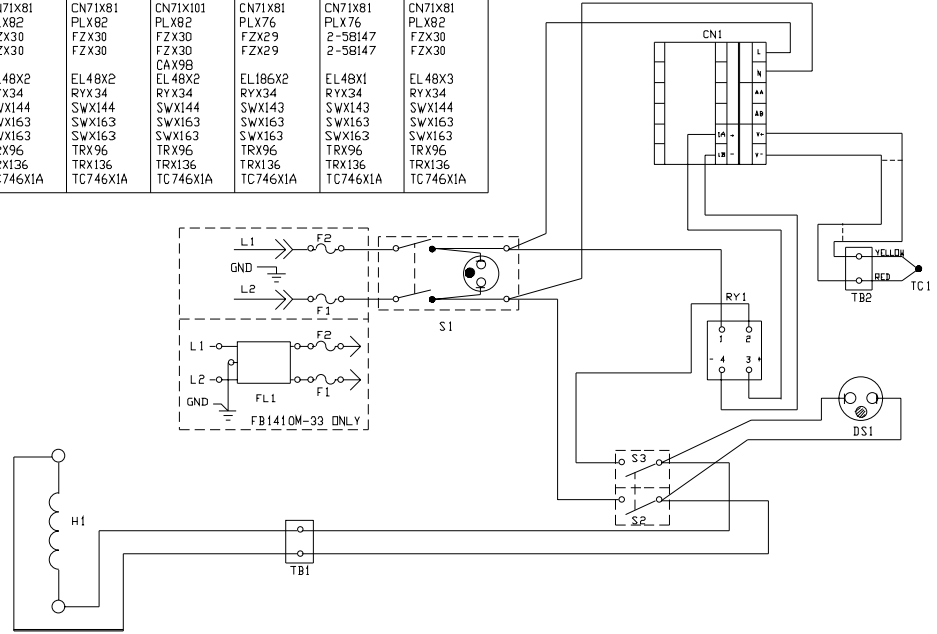
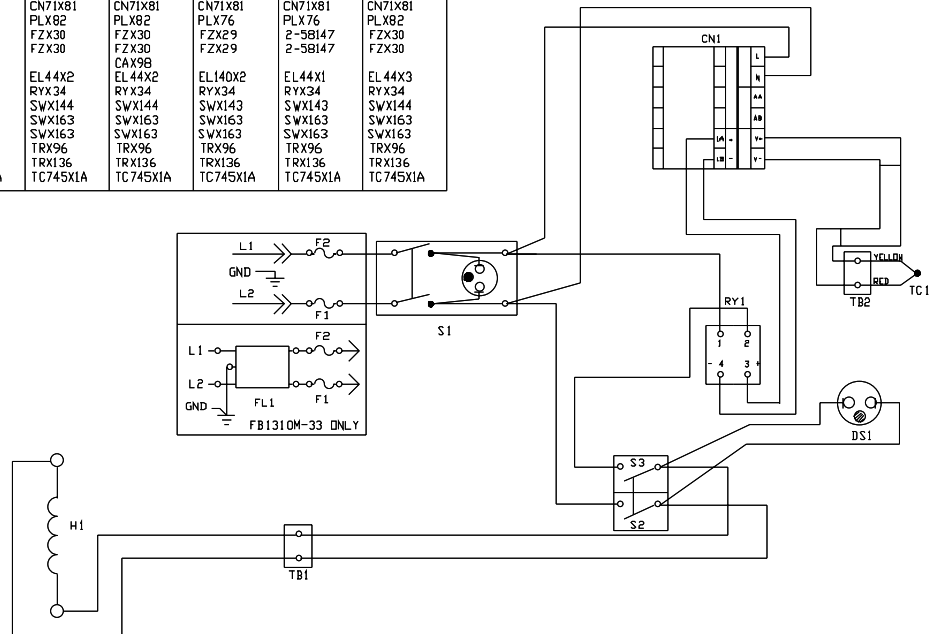

DIAGRAM COMPONENT LIST

REF. NO.	DESCRIPTION	MODEL NO. AND OUR PART NO.(S)					
		FB1310M	FB1310M-26	FB1310M-33	FB1314M	FB1315M	FB1318M
CN1	CONTROL	CN71X81	CN71X81	CN71X81	CN71X81	CN71X81	CN71X81
DS1	PILOT LIGHT	PLX82	PLX82	PLX82	PLX76	PLX76	PLX82
F1	FUSE	FZX30	FZX30	FZX30	FZX29	2-58147	FZX30
F2	FUSE	FZX30	FZX30	FZX30	FZX29	2-58147	FZX30
FL1	CAPACITOR			CAX98			
H1	HEATING ELEMENT	EL44X2	EL44X2	EL44X2	EL140X2	EL44X1	EL44X3
RY1	RELAY, SOLID STATE	RXX34	RXX34	RXX34	RXX34	RXX34	RXX34
S1	SWITCH, POWER	SWX144	SWX144	SWX144	SWX143	SWX143	SWX144
S2	SWITCH, DOOR	SWX163	SWX163	SWX163	SWX163	SWX163	SWX163
S3	SWITCH, DOOR	SWX163	SWX163	SWX163	SWX163	SWX163	SWX163
TB1	TERMINAL BLOCK	TRX96	TRX96	TRX96	TRX96	TRX96	TRX96
TB2	TERMINAL BLOCK	TRX136	TRX136	TRX136	TRX136	TRX136	TRX136
TC1	THERMOCOUPLE	TC745X1A	TC745X1A	TC745X1A	TC745X1A	TC745X1A	TC745X1A

FB1300 models



Exploded View

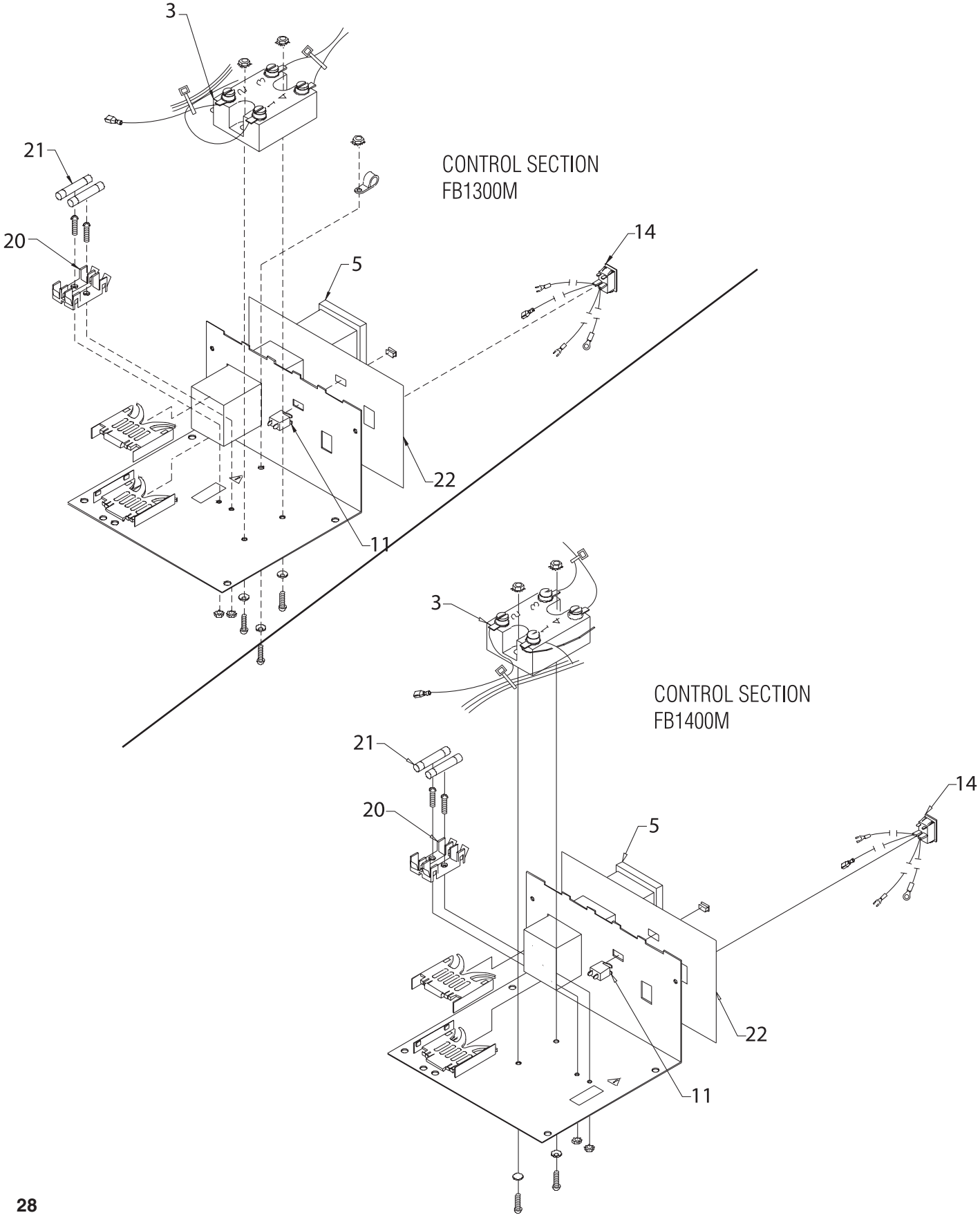

EXPLODED VIEW

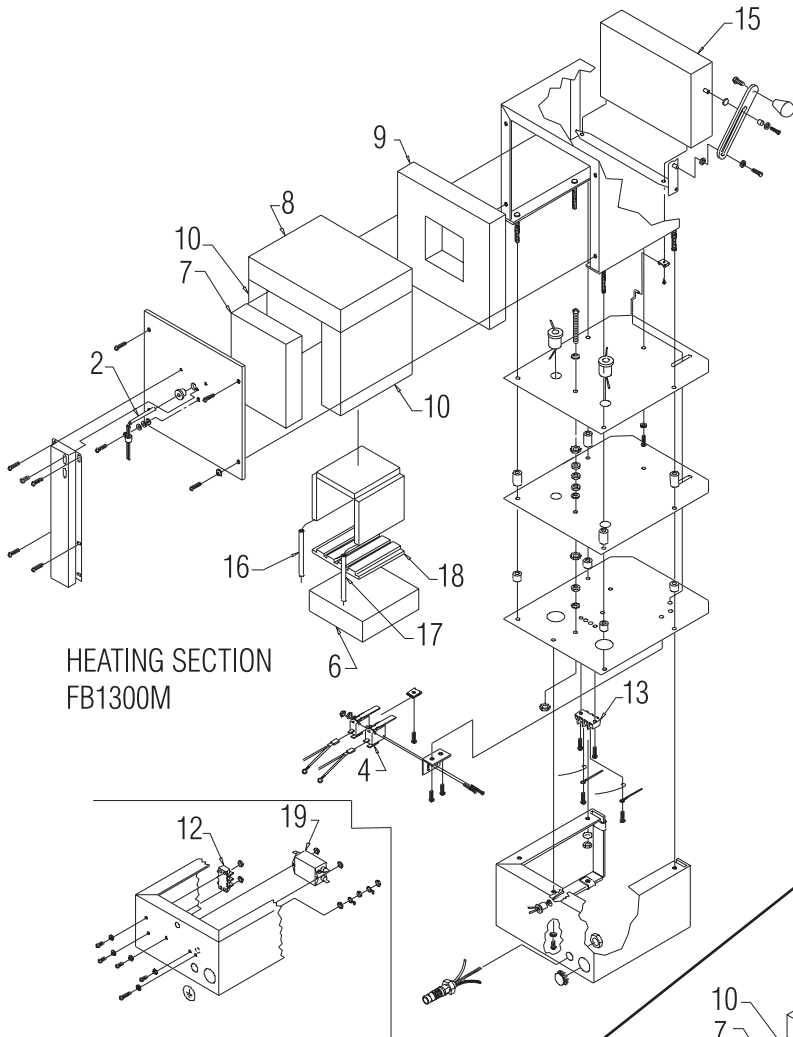

HEATING SECTION
FB1300M

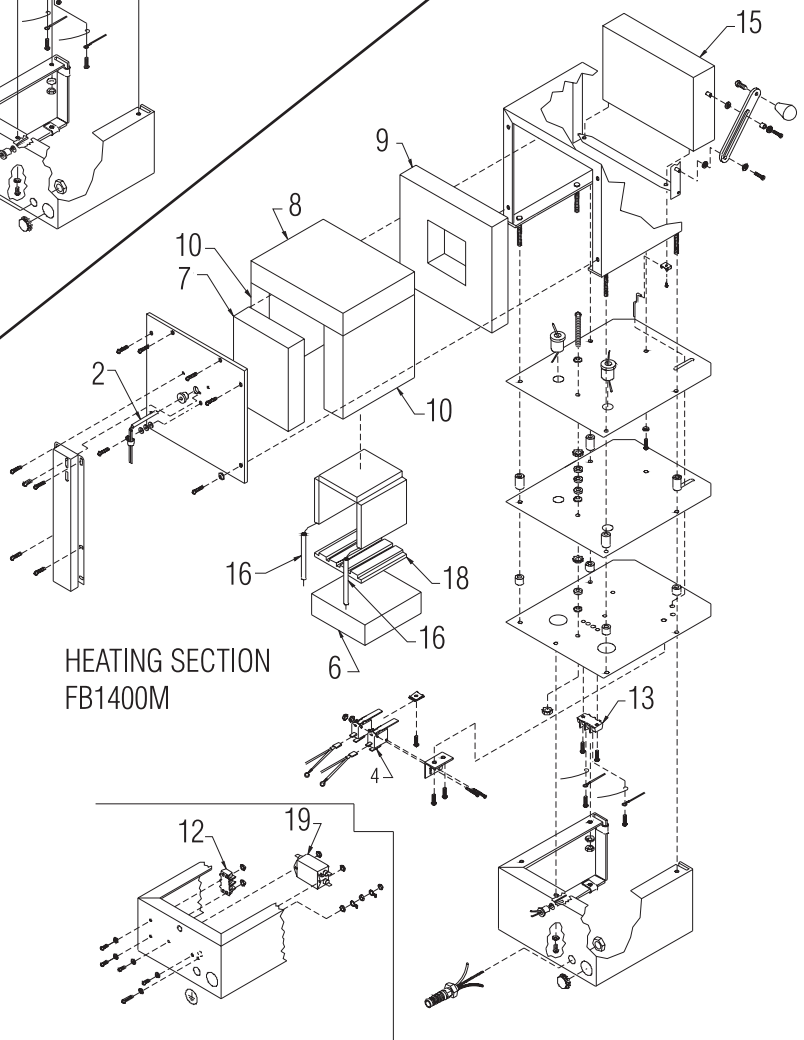

HEATING SECTION
FB1400M

Replacement Parts List

<u>Key#</u>	<u>Description</u>	<u>Quantity Required</u>	<u>Part Number</u>
1	Heating element (100V - FB1314M)	1	EL140X2
1	Heating element (120V - FB1315M)	1	EL44X1
1	Heating element (208V - FB1318M)	1	EL44X3
1	Heating element (240V - FB1310M, -33)	1	EL44X2
1	Heating element (100V - FB1414M)	1	EL186X2
1	Heating element (120V - FB1415M)	1	EL48X1
1	Heating element (208V - FB1418M)	1	EL48X3
1	Heating element (208V - FB1410M, -33)	1	EL48X2
2	Thermocouple (FB1300 models)	1	TC1256X1
2	Thermocouple (FB1400 models)	1	TC746X1A
3	Solid State Relay (all models)	1	RYX34
4	Door Switches (all models)	2	SWX163
5	Control (FB1300M & FB1400M models except FB1410M-33)	1	CN71X81
5	Control (FB1400M-33 model only)	1	CN71X101
6	Insulation Btm (all FB1300 models)	1	JC44X1
6	Insulation Btm (all FB1400 models)	1	JC48X2
7	Insulation Back (all FB1300 models)	1	JC44X4
7	Insulation Back (all FB1400 models)	1	JC48X1
8	Insulation Top (all FB1300)	1	JC44X3
8	Insulation Top (all FB1400)	1	JC48X3
9	Insulation Hearth Collar (FB1300)	1	HC44X1
9	Insulation Hearth Collar (FB1400)	1	HC48X1
10	Insulation Sides (FB1300)	2	JC460X2
10	Insulation Sides (FB1400)	2	JC48X4
11	Cycle Light (amber) (all 100V & 120V)	1	PLX76
11	Cycle Light (amber) (all 208V & 240V)	1	PLX82
12	Terminal Block	1	TRX136
13	Terminal Block	1	TRX96
14	Power Switch (100 & 120V models)	1	SWX143
14	Power Switch (208 & 240V models)	1	SWX144
15	Door Assembly (FB1300 all models)	1	DR347X1A
15	Door Assembly (FB1400 all models)	1	DR348X1A
16	Element Sleeving (all models)	1	SL745X1
17	Element Sleeving (all FB1300 models)	1	SL59X2
18	Hearth Plate (all FB1300 models)	1	PH44X1
18	Hearth Plate (all FB1400 models)	1	PH48X1
19	Filter (all -33 models)	1	CAX98
20	Fuse Holder (all models)	1	FZX26
21	Fuse 10 amp .25 x 1.25 - (Buss™ Type ABC, 240V & 208V models)	2	FZX30
21	Fuse 15 amp .25 x 1.25 (Buss™ Type ABC, 120V models)	2	2-58147
21	Fuse 20 amp .25 x 1.25 (Buss™ Type ABC, 100V models)	2	FZX29
22	Dial Plate Label (FB1300)	1	DLX248
22	Dial Plate Label (FB1400)	1	DLX249

Ordering Procedures

Please refer to the Specification Plate for the complete model number, serial number, and series number when requesting service, replacement parts or in any correspondence concerning this unit.

All parts listed herein may be ordered from the Barnstead International dealer from whom you purchased this unit or can be obtained promptly from the factory. When service or replacement parts are needed we ask that you check first with your dealer. If the dealer cannot handle your request, then contact our Customer Service Department at 563-556-2241 or 800-553-0039.

Prior to returning any materials to Barnstead International, please contact our Customer Service Department for a "Return Goods Authorization" number (RGA). Material returned without a RGA number will be refused.

One Year Limited Warranty

BARNSTEAD INTERNATIONAL (“BARNSTEAD”) warrants that if a product manufactured by Barnstead shall be free of defects in materials and workmanship for one (1) year from the first to occur of (i) the date the product is sold by BARNSTEAD or (ii) the date the product is purchased by the original retail customer (the “Commencement Date”). Except as expressly stated above, BARNSTEAD MAKES NO OTHER WARRANTY, EXPRESSED OR IMPLIED, WITH RESPECT TO THE PRODUCTS AND EXPRESSLY DISCLAIMS ANY AND ALL WARRANTIES, INCLUDING BUT NOT LIMITED TO, WARRANTIES OF DESIGN, MERCHANT ABILITY AND FITNESS FOR A PARTICULAR PURPOSE.

An authorized representative of BARNSTEAD must perform all warranty inspections. In the event of a defect covered by BARNSTEAD’s warranty, BARNSTEAD shall, as its sole obligation and exclusive remedy, provide free replacement parts to remedy the defective product. In addition, for products sold by BARNSTEAD within the continental United States or Canada, BARNSTEAD shall provide provide free labor to repair the products with the replacement parts, but only for a period of ninety (90) days from the Commencement Date.

BARNSTEAD’s warranty provided hereunder shall be null and void and without further force or effect if there is any (i) repair made to the product by a party other than BARNSTEAD or its duly authorized service representative, (ii) misuse (including use inconsistent with written operating instructions for the product), mishandling, contamination, overheating, modification or alteration of the product by any customer or third party or (iii) use of replacement parts that are obtained from a party who is not an authorized dealer of BARNSTEAD.

Heating elements, because of their susceptibility to overheating and contamination, must be returned to the BARNSTEAD factory and if, upon inspection, it is concluded that failure is due to factors other than excessive high temperature or contamination, BARNSTEAD will provide warranty replacement. As a condition to the return of any product, or any constituent part thereof, to BARNSTEAD’s factory, it shall be sent prepaid and a prior written authorization from BARNSTEAD assigning a Return Goods Number to the product or part shall be obtained.

IN NO EVENT SHALL BARNSTEAD BE LIABLE TO ANY PARTY FOR ANY DIRECT, INDIRECT, SPECIAL, INCIDENTAL, OR CONSEQUENTIAL DAMAGES, OR FOR ANY DAMAGES RESULTING FROM LOSS OF USE OR PROFITS, ANTICIPATED OR OTHERWISE, ARISING OUT OF OR IN CONNECTION WITH THE SALE, USE OR PERFORMANCE OF ANY PRODUCTS, WHETHER SUCH CLAIM IS BASED ON CONTRACT, TORT (INCLUDING NEGLIGENCE), ANY THEORY OF STRICT LIABILITY OR REGULATORY ACTION.

The name of the authorized Barnstead International dealer nearest you may be obtained by calling 1-800-446-6060 (563-556-2241) or writing to:

 **Barnstead**International
an Apogent company *Your Lab Starts Here*

2555 Kerper Boulevard
P.O. Box 797
Dubuque, Iowa 52001-0797
Phone: 563-556-2241 or 800-553-0039
Fax: 563-589-0516
E-mail: mkt@barnstead.com
www.barnstead.com

