

Microfluidics Lab Sherline / Flashcut CNC Mill assembly and maintenance

Revised and Updated by for UCSB Soh Lab by UCSB Capstone Team 19,2012

ASSEMBLY INSTRUCTION

TITLE: Replacement Plate Assembly Rev. 1

EFFECTIVE DATE: 5/21/12

Page 2 of 13

APPROVED:

APPROVED:

Quality Assurance

Responsible Department Manager

The program begins by opening the specified DXF file and reading the contents into a large string. A parser consisting of regular expression VIs inside a *while* loop is used to read the (x; y) locations of each hole to be drilled. The values in the resulting 2 by n array (where n is the number of holes to drill) are converted to millimeters if necessary and fed pairwise, one hole at a time, into the main *for* loop. This loop feeds the DXF hole coordinates plus the parameters specified on the front panel to the *cadlogic.vi* sub-VI, which returns the new coordinates of the hole in the mill's coordinate system. A large concatenation operation adds necessary G-code statements and builds a single large string which is finally saved as the output FGC file. The program maintains a usage log at *c:\ncnclog.txt*; this default location can be changed in the diagram code.

4 System Maintenance

4.1 Resetting the location of the vacuum chuck

For a variety of reasons, the location of the vacuum chuck may change from its original location. This will result in the loss of functionality of the coordinate transformation as described in section 2.5c, because this method is dependent on the vacuum chuck location. Follow these steps in order to reprogram the location of the vacuum chuck inside of LabVIEW.

1. Open *dx2f2fgc.vi* and select the circular wafer from approximate center tab
2. Open Flashcut
3. Manually jog the spindle to the location of the approximate center of the vacuum chuck
4. Find the reprogram center box located at the bottom of the VI screen, as shown

ASSEMBLY INSTRUCTION

TITLE: **Replacement Plate Assembly**

Rev. 1

EFFECTIVE DATE: 5/21/12

Page 3 of 13

APPROVED:

APPROVED:

Quality Assurance

Responsible Department Manager

<table border="1" style="width: 100%; border-collapse: collapse;"> <tr><td style="text-align: center;">10630.0</td><td style="text-align: center;">-22500.0</td></tr> <tr><td style="text-align: center;">11130.0</td><td style="text-align: center;">-8500.0</td></tr> <tr><td style="text-align: center;">-7600.0</td><td style="text-align: center;">-5000.0</td></tr> <tr><td style="text-align: center;">-7600.0</td><td style="text-align: center;">-8500.0</td></tr> <tr><td style="text-align: center;">-18870.0</td><td style="text-align: center;">-8500.0</td></tr> <tr><td style="text-align: center;">-4800.0</td><td style="text-align: center;">-22500.0</td></tr> <tr><td style="text-align: center;">-8300.0</td><td style="text-align: center;">-22500.0</td></tr> <tr><td style="text-align: center;">-19370.0</td><td style="text-align: center;">-22500.0</td></tr> </table>	10630.0	-22500.0	11130.0	-8500.0	-7600.0	-5000.0	-7600.0	-8500.0	-18870.0	-8500.0	-4800.0	-22500.0	-8300.0	-22500.0	-19370.0	-22500.0	<table border="1" style="width: 100%; border-collapse: collapse;"> <tr><td style="text-align: center;">10630.000000</td><td style="text-align: center;">-22500.000000</td></tr> <tr><td style="text-align: center;">11130.000000</td><td style="text-align: center;">-8500.000000</td></tr> <tr><td style="text-align: center;">-7600.000000</td><td style="text-align: center;">-5000.000000</td></tr> <tr><td style="text-align: center;">-7600.000000</td><td style="text-align: center;">-8500.000000</td></tr> <tr><td style="text-align: center;">-18870.000000</td><td style="text-align: center;">-8500.000000</td></tr> <tr><td style="text-align: center;">-4800.000000</td><td style="text-align: center;">-22500.000000</td></tr> <tr><td style="text-align: center;">-8300.000000</td><td style="text-align: center;">-22500.000000</td></tr> <tr><td style="text-align: center;">-19370.000000</td><td style="text-align: center;">-22500.000000</td></tr> </table>	10630.000000	-22500.000000	11130.000000	-8500.000000	-7600.000000	-5000.000000	-7600.000000	-8500.000000	-18870.000000	-8500.000000	-4800.000000	-22500.000000	-8300.000000	-22500.000000	-19370.000000	-22500.000000	<table border="1" style="width: 100%; border-collapse: collapse;"> <tr><td style="text-align: center;">10.63</td></tr> <tr><td style="text-align: center;">11.13</td></tr> <tr><td style="text-align: center;">-7.60</td></tr> <tr><td style="text-align: center;">-7.60</td></tr> <tr><td style="text-align: center;">-18.87</td></tr> <tr><td style="text-align: center;">-4.80</td></tr> <tr><td style="text-align: center;">-8.30</td></tr> <tr><td style="text-align: center;">-19.37</td></tr> </table>	10.63	11.13	-7.60	-7.60	-18.87	-4.80	-8.30	-19.37
10630.0	-22500.0																																									
11130.0	-8500.0																																									
-7600.0	-5000.0																																									
-7600.0	-8500.0																																									
-18870.0	-8500.0																																									
-4800.0	-22500.0																																									
-8300.0	-22500.0																																									
-19370.0	-22500.0																																									
10630.000000	-22500.000000																																									
11130.000000	-8500.000000																																									
-7600.000000	-5000.000000																																									
-7600.000000	-8500.000000																																									
-18870.000000	-8500.000000																																									
-4800.000000	-22500.000000																																									
-8300.000000	-22500.000000																																									
-19370.000000	-22500.000000																																									
10.63																																										
11.13																																										
-7.60																																										
-7.60																																										
-18.87																																										
-4.80																																										
-8.30																																										
-19.37																																										

X, Y Values of Home to Center Offset <----- ONLY CHANGE THESE VALUES IF
G52 X70.052 Y98.269 THE CHUCK BASE IS MOVED!!!!
 USE FLASHCUT AND JOG THE SPINDLE
 TO THE CHUCK CENTER TO GET A NEW
 OFFSET.

5. Type in the x and y coordinates as shown on Flashcut, be careful to only change the coordinates, and leave the other formatting.

ASSEMBLY INSTRUCTION

TITLE: Replacement Plate Assembly Rev. 1

EFFECTIVE DATE: 5/21/12

Page 4 of 13

APPROVED:

APPROVED:

Quality Assurance

Responsible Department Manager

4.2 Replacing the camera

The camera model is an Oasis Scientific 2.0 MP, 8mm USB Digital Microscope, available from Amazon.com

4.3 Replacing the vacuum chuck heads

1. PURPOSE

- 1.1. This assembly instruction describes the assembly of the modified vacuum chuck with its matching replacement top plates.

2. REFERENCES

2.1 Assembly Drawings:

- 004-005RevB, Vacuum Chuck Assy

2.2 Part Drawings:

- 003-004RevA, Replacement Top Plate
- 010-003RevA, Replacement Plate Rectangular
- 013-001RevA, Chuck Base Final

ASSEMBLY INSTRUCTION

TITLE: **Replacement Plate Assembly** Rev. 1

ASSEMBLY INSTRUCTION

TITLE: **Replacement Plate Assembly** **Rev. 1**

3. RESPONSIBILITIES

3.1 The assembler is responsible for using the latest revision of this Assembly procedure listed in the commodity code database, unless otherwise directed by Dave Bothman.

4. REQUIRED EQUIPMENT

<u>Tools</u>
#6 (7/64") Allen Key

<u>Hardware</u>		
<u># needed</u>	<u>McMaster Part #</u>	<u>Description</u>
2	91251A345	Type 316 Stainless STL Socket Head Cap Screw 10-32 Thread, 3/4" Length

5. PROCEDURE FOR ASSEMBLY AND TEST

Follow procedures in sequential order as follows:

ASSEMBLY INSTRUCTION

TITLE: **Replacement Plate Assembly** Rev. 1

Section 1: Removal of current plate (if one is present)

Parts

1x 013-001RevA, Chuck Base Final

1x 010-003RevA, Replacement Plate Rectangular

OR

003-004RevA, Replacement Top Plate

Hardware

No additional hardware needed

2x (6-32 SHCS x .75" Long already in place)

Tools

#6 (7/64") Allen Key

Background: This procedure will disassemble the chuck base (013-001RevA, Chuck Base Final) and any top plate in place (010-003RevA, Replacement Plate Rectangular **OR** 003-004RevA, Replacement Top Plate).

ASSEMBLY INSTRUCTION

TITLE: Replacement Plate Assembly

Rev. 1

Step 1.1

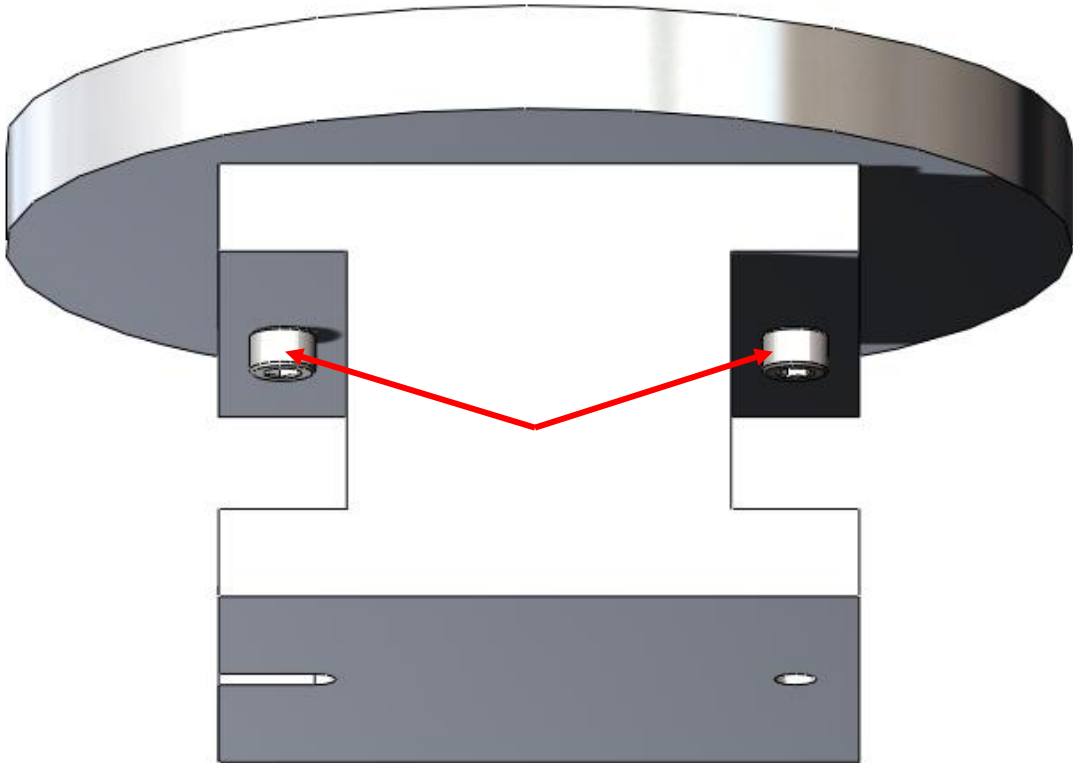

Step 1.1)

Locate the 2 #10-32 screws where shown.

Items

1x 010-003RevA, Replacement Plate Rectangular

1x 013-001RevA, Chuck Base Final

2x 91251A345

ASSEMBLY INSTRUCTION

TITLE: Replacement Plate Assembly

Rev. 1

Step 1.2

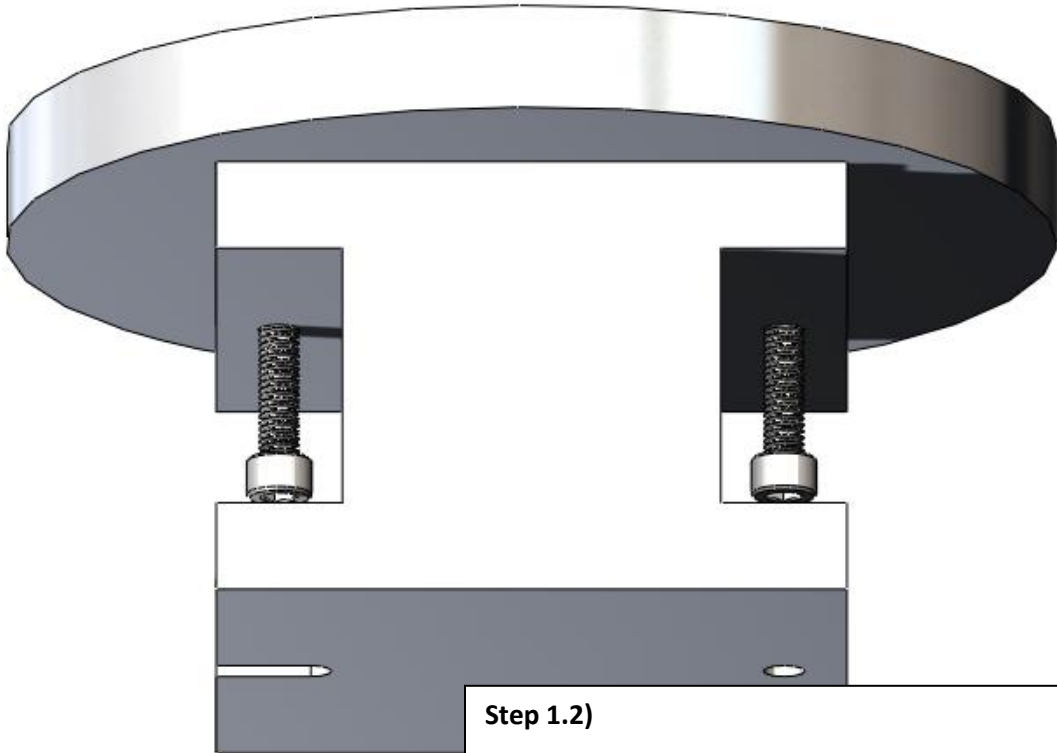

Step 1.2)

Unscrew as shown using #6 (7/64") Allen Key.

Items

1x 010-003RevA, Replacement Plate
Rectangular

1x 013-001RevA, Chuck Base Final

2x 91251A345

1x #6 (7/64") Allen Key

ASSEMBLY INSTRUCTION

TITLE: **Replacement Plate Assembly**

Rev. 1

Step 1.3

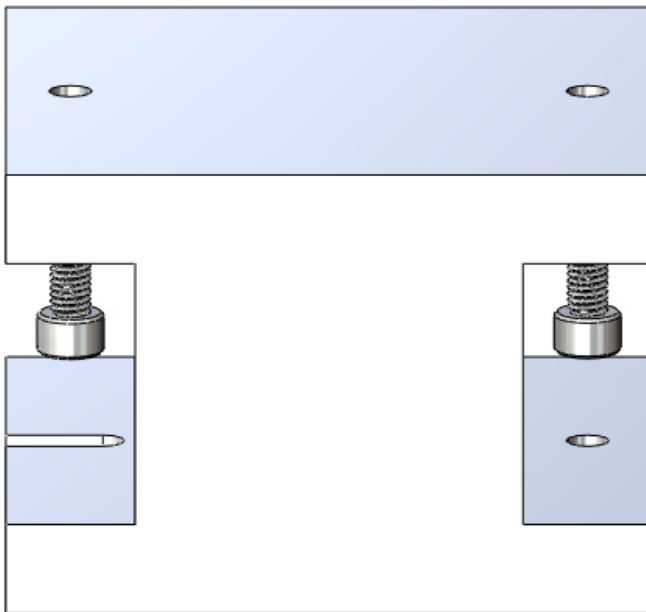

Step 1.3)

Remove replacement plate as shown.

Items

1x 013-001RevA, Chuck Base Final

2x 91251A345

ASSEMBLY INSTRUCTION

TITLE: **Replacement Plate Assembly** **Rev. 1**

Section 2: Assembly of top plate once vice chuck top surface is exposed

Parts

1x 013-001RevA, Chuck Base Final

1x 010-003RevA, Replacement Plate Rectangular

OR

003-004RevA, Replacement Top Plate

Hardware

No additional hardware needed

2x (6-32 SHCS x .75" Long already in place)

Tools

#6 (7/64") Allen Key

ASSEMBLY INSTRUCTION

TITLE: Replacement Plate Assembly

Rev. 1

Step 2.1

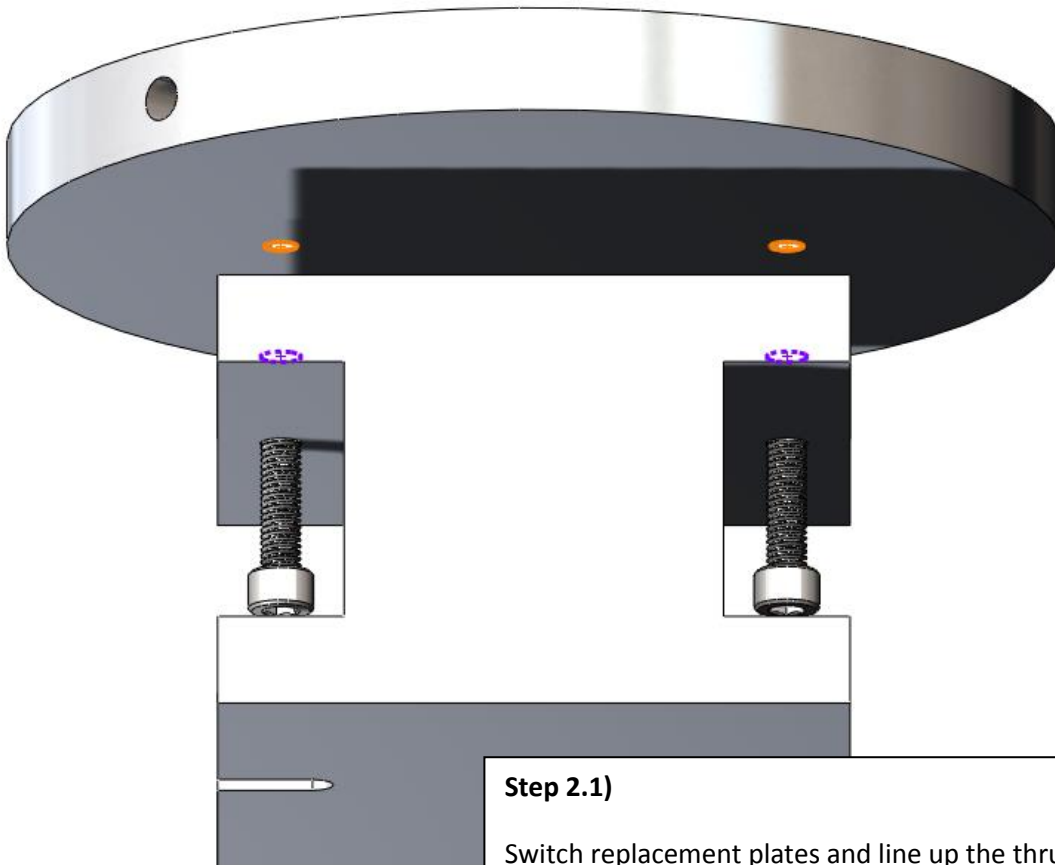

Step 2.1)

Switch replacement plates and line up the thru holes in the base with the threaded holes in the top plate (as shown).

Items

1x 013-001RevA, Chuck Base Final

1x 003-004RevA, Replacement Top Plate

2x 91251A345

ASSEMBLY INSTRUCTION

TITLE: **Replacement Plate Assembly** Rev. 1

Step 2.2

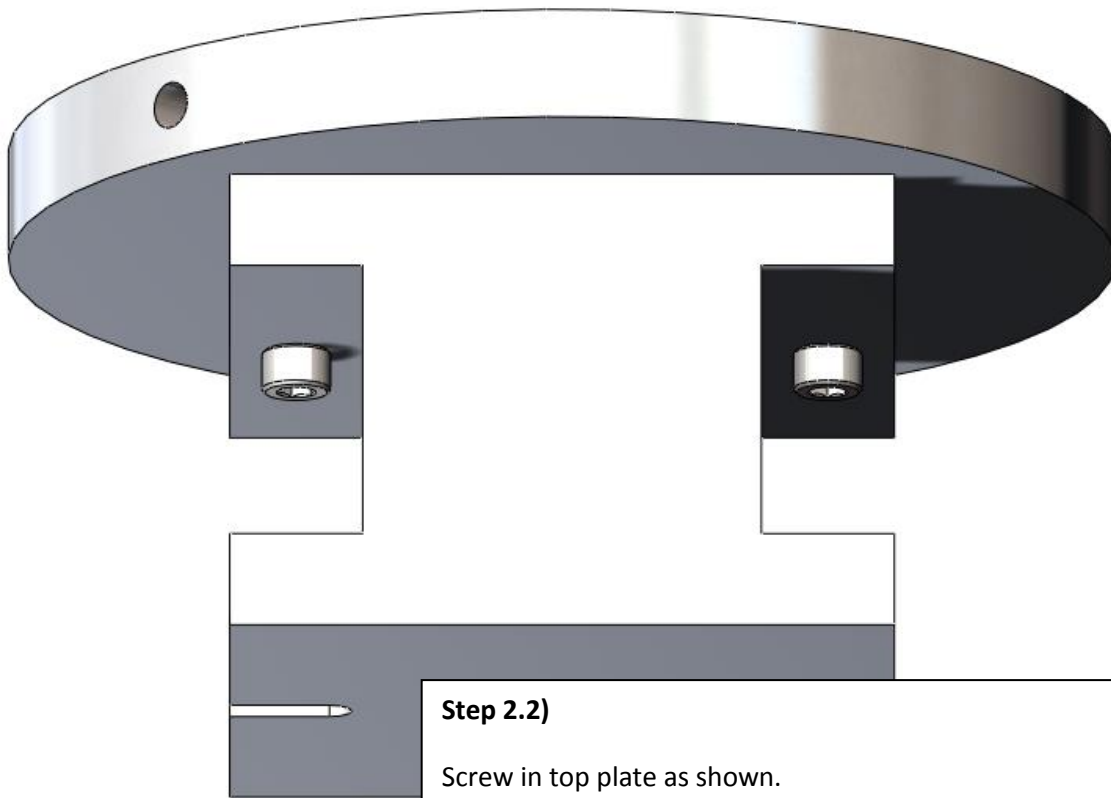

Step 2.2)

Screw in top plate as shown.

Items

1x 013-001RevA, Chuck Base Final

1x 003-004RevA, Replacement Top Plate

2x 91251A345

1x #6 (7/64") Allen Key