

STRIATECH.

where mind meets motor



the official look book

shop at www.striatech.com

More Than Motors

Striatech has been answering the call to innovation since its beginning.

Tired of traditional AC and DC motors – which, while ubiquitous, are noisy and rather unreliable – the minds behind Striatech began powering switch reluctance motors with ground-breaking technology. The result? A silent, highly controllable and programmable, durable motor.

The results have been staggering. Our customers have implemented these motors in woodworking and metalworking tools, pumps, dust collectors, winches, HVAC systems and more. In each of these applications, we've seen significant energy savings – more than 50% energy savings over a traditional AC motor. These motors require limited maintenance, offer extensive safety features and allow for remarkable flexibility in applications.

Because of the technology, the motor can adapt its behavior to the environment and adjust accordingly. That's exactly what it sounds like: a motor that thinks for you.

Despite this incredible innovation, Striatech is not a company that is happy to rest on its laurels. The innovation pipeline at Striatech is always full – bursting with ideas for new applications, improvements to the software and ways to enhance our technology.

*Striatech's mission is simple. We are much more than just a company that makes motors; we are a company that creates **solutions**.*



The Mind in Motion

Switch reluctance has many advantages over its competitors. In our motors, we have perfected the simple construction: no brushes, no commutators, and no permanent magnets in our MF, MM and DF Series of motors.

The "smart" part of our motor is a point of pride for us.

Switched reluctance has a great deal of merit on its own in motor technology, but when paired with our controller, the motor takes on a whole new dynamic. Striatech's motor is able to control torque and utilize electronic braking even from top speeds.

It's the intelligence of our motor that our name relates to. The root of the word "Striatech" is Striatum. This is the anatomical part of the human brain that is responsible for directing movement. Neuroscientists call it "motor control" – and so do we. The controller is the mind, and the motor is the muscle.

That's why Striatech is where mind meets motor.



The SF Series

Striatech's SF Motor Series offers a single firing motor that provides a cost-efficient option that is capable of reaching high speeds.

This particular motor offers speeds between 1,000-14,000 RPM. As it is still equipped with the intelligent electronic control within Striatech's line, it is capable of self-adjusting speed and power to suit its environmental conditions. Motors in this series can come with either a built-in or separate controller.

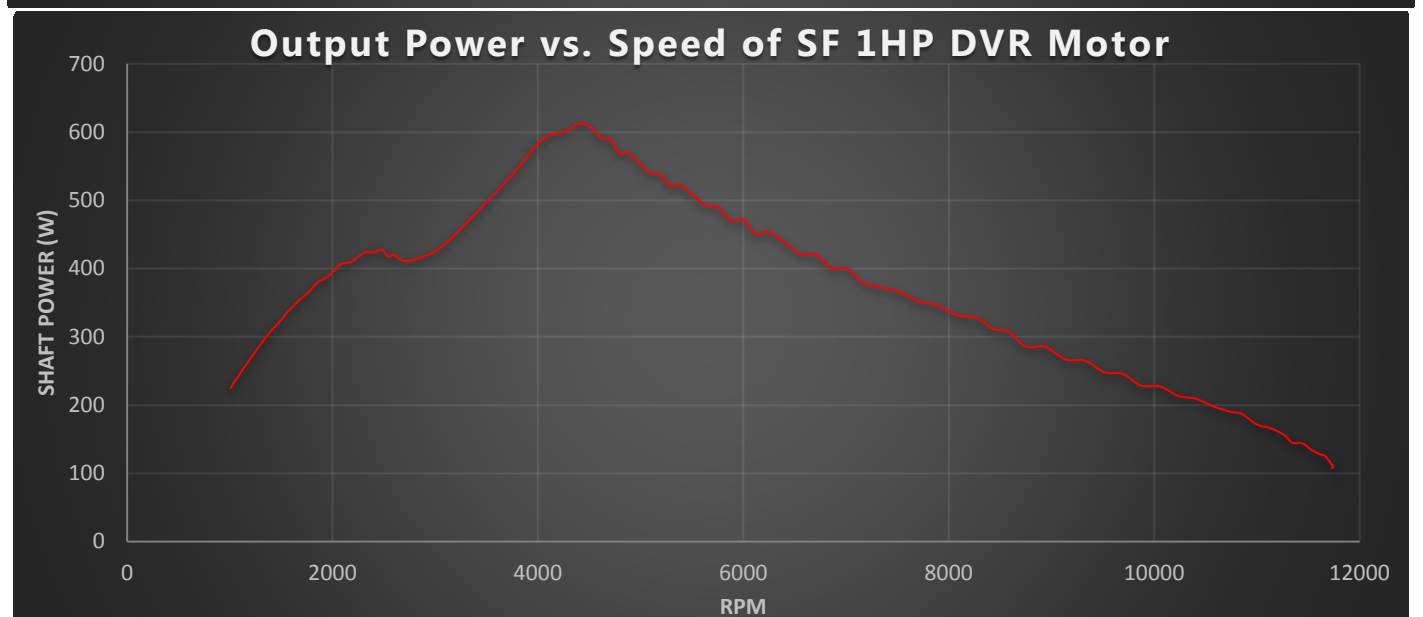
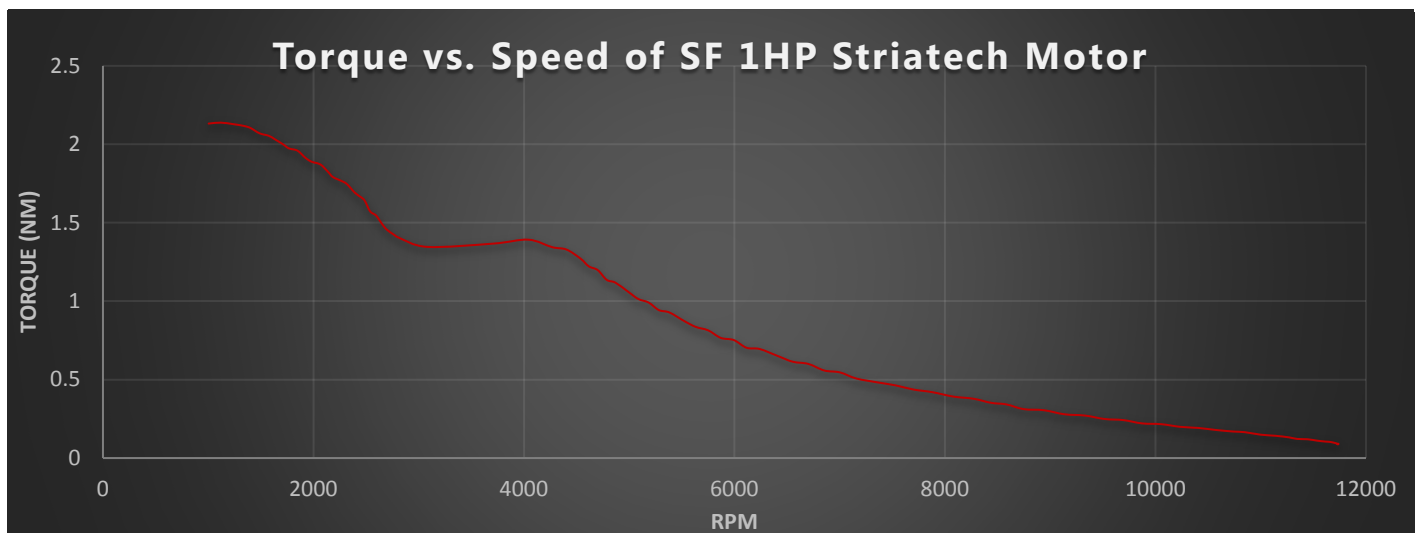

Sizes and Specifics for the SF Series

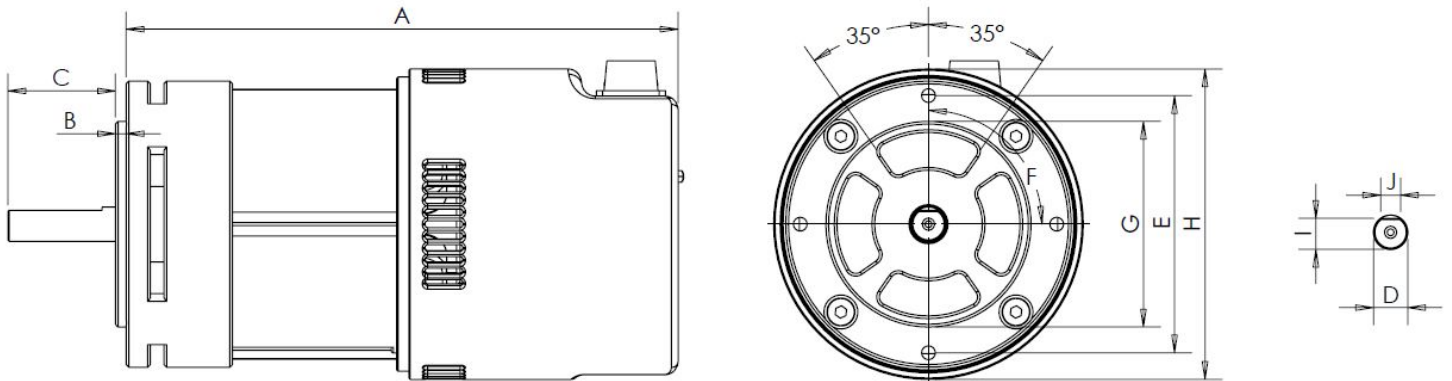

Model	Power (W)	HP	Frame	RPM Range	A mm	B mm	C mm	D mm	E mm	F mm	G mm	H mm	I mm	J mm	Tap Size
SF100	750	1	NEMA4 8C	1000- 5000	185.5	3.18	39.62	12.7	95.25	90	76.2	111.79	11.51	7.4	¼"- 20

Contact Striatech for complete pricing information on the SF Series.

Email: sales@striatech.com | Phone: Phone: 727.202.9932

Case Study:

Shopsmith's Revitalization

Problem:

A machine designed and developed during the post-World War II do-it-yourself boom has a great deal of charm. A company called Shopsmith manufactured such a machine. Their all-in-one multi-tool specific to woodworking occupied a large number of workshops across the world until very recently. Sales boomed for the first three decades, as people rushed to get the machine that is so versatile that it can complete with an entire shop. But, in its construction, there were a few compromises. Users were challenged by the careful planning required to convert one tool function to the next. Eventually, the rise of single-function machines took over Shopsmith's market share. As these standalone tools became lower-cost and more functional, the demand for this bulky multi-tool faded.

Solution:

That did not stop Shopsmith from working toward re-inventing their machine. Their research determined that the next generation of machines required an advanced powertrain to be successful. The solution became apparent in 2010, when Shopsmith implemented the Striatech motor into their new Mark VII machine. This was the start of Shopsmith's PowerPro line, which was a perfectly, delicately configured controller that helped make use of the multi-tool easier than ever.

The PowerPro was so successful that Shopsmith began retrofitting its older machines with the new Striatech motor. The change resulting in a power boost from 1HP to 1.75HP, doubling the torque and offering an increase in the depths of cut and feed rates. It gives the machine a 10,000rpm speed range, which gives the users professional-level results. By adding in a reverse component, it made it possible to do bi-directional sanding as well.



User Experience:

"While the old Shopsmith headstock achieved a useful 7 to 1 speed variation, using variable pitch pulleys, the DVR powered Power Pro has a 40 to 1 speed range, 250 to 10,000 rpm, providing full torque throughout. The computer/controller also has a mode that can assist in selecting the proper speed for a particular operation. The computer senses the load, and automatically provides the necessary torque. The smooth and quiet operation is impressive. Placing a cup of coffee on the table reveals nary a ripple, even at 10,000 rpm."

"Rated at 2 HP on 240 volt, users will find that the Power Pro's ability to sense torque makes it possible to do table saw ripping equal to many cabinet saws. Additionally, the variable speed feature has made it possible for me to rip and crosscut curly maple and cherry without getting burn marks. At 250 rpm in lathe mode, I can turn heavy stock, up to 16" diameter. Likewise, as a drill press, the Power Pro provides the necessary power to drill with large diameter forstner bits with ease. At 10,000 rpm, it can spin larger diameter

shaper and router bits with more power than available with traditional routers. While multi-purpose tools are not for everyone, this upgrade gives those who must work in very small shops, like my 192 sq. ft., the increased power and capability of many larger stand alone machines."



- From ["Wow! This isn't grandpa's old Shopsmith"](#), by [Lumberjocks.com](#)

The MF Series

This series of motors is Striatech's flagship line. It brings next-generation intelligence along with a high-powered, highly customizable motor – combined to create the ideal solution across a variety of applications.

MF motors live inside the NOVA Voyager Drill Press and several of NOVA's wood lathes. In fact, Striatech has been implementing and innovating its products in NOVA's wood lathes for nearly a decade – withstanding the test of time and breathing new life into the woodturning industry.

But it's so clear that these motors can do more than just power woodturning machines. They've been applied to integrated fluid handling applications, conveyor systems and HVAC solutions – and have integrated seamlessly into each of these applications. This line of motors can be utilized as Package Drive motors, featuring four main customizable base configurations.

The broad range of capabilities is what many find most impressive. These smart motors can reduce current draw based on load in order to reduce power consumption. The HMI (Human Machine Interface) Board can be programmed and reprogrammed for any application. Plus, the motors can be paired with a wireless remote to make use even easier.



Striatech's MF Series						
Maximum Torque Deliver Speed (Base Speed), rpm	Max Torque, N-m	@ rpm	Max Power, W	@ rpm	Start Torque, N-m	Start Torque safe until ~XXX rpm
1800	16.82	@ 220	1354	@ 1769	13.4	847
1000	19.75	@ 171	1349	@ 1535	17.22	567
600	21.89	@ 125	1317	@ 1098	21.1	421

Torque Curve: 600rpm Maximum Torque Delivery Speed (Base Speed)

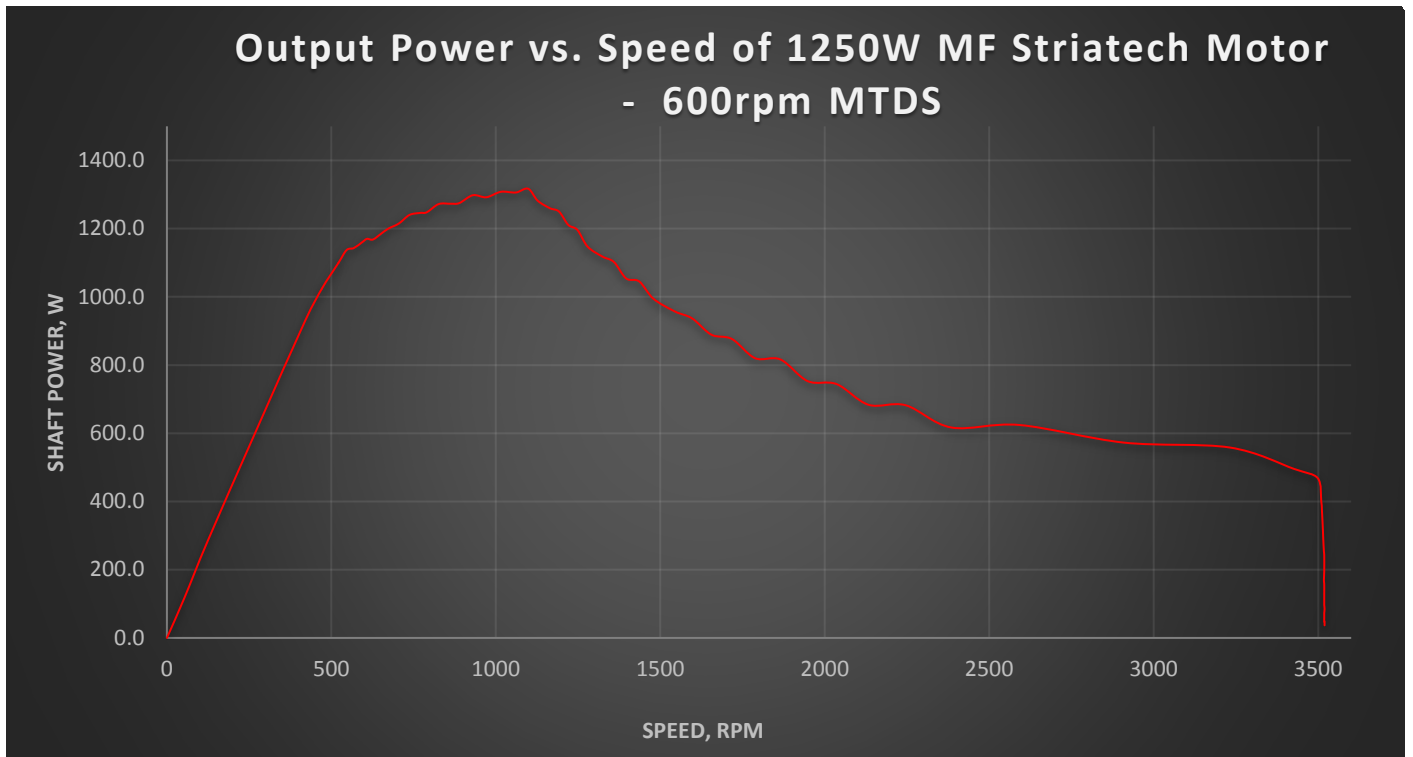
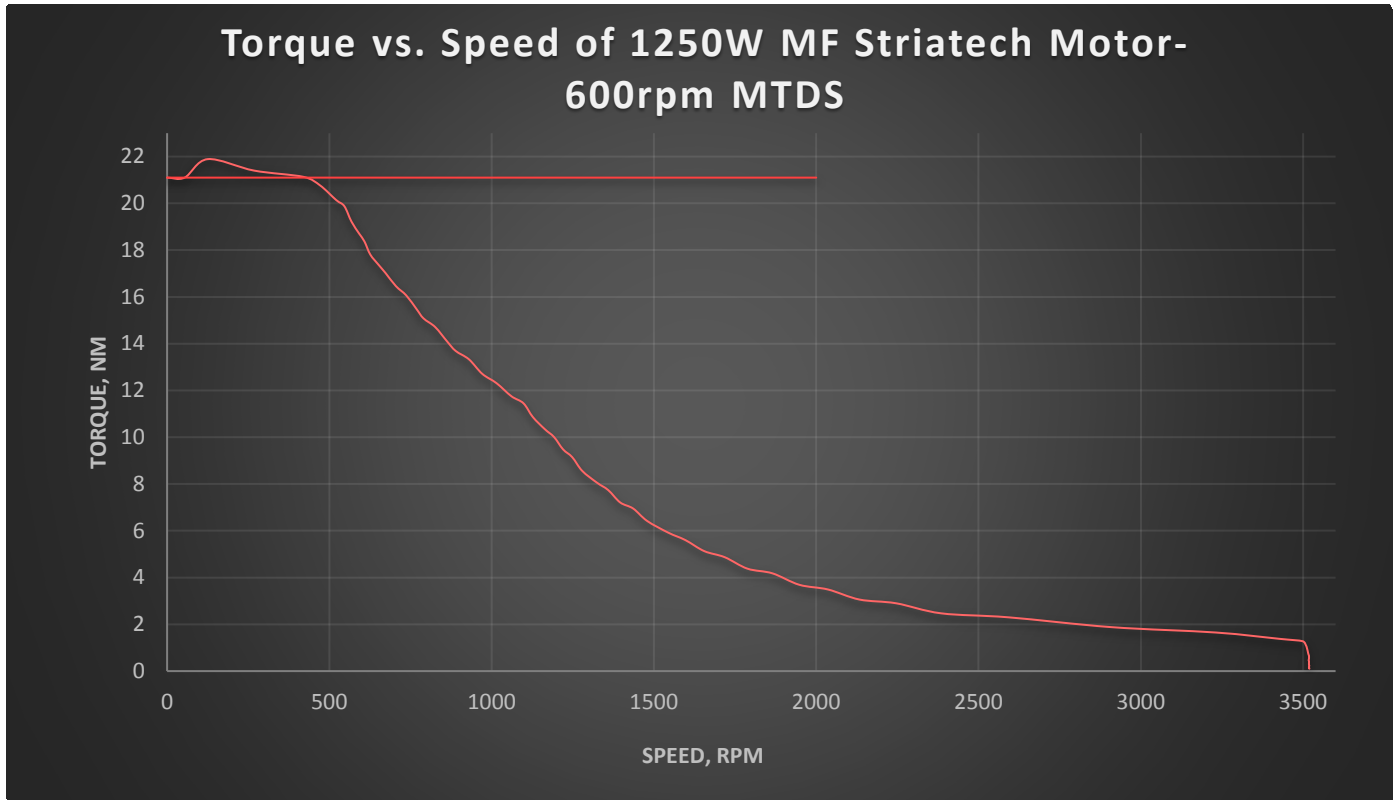

Torque Curve: 1000rpm Maximum Torque Delivery Speed (Base Speed)

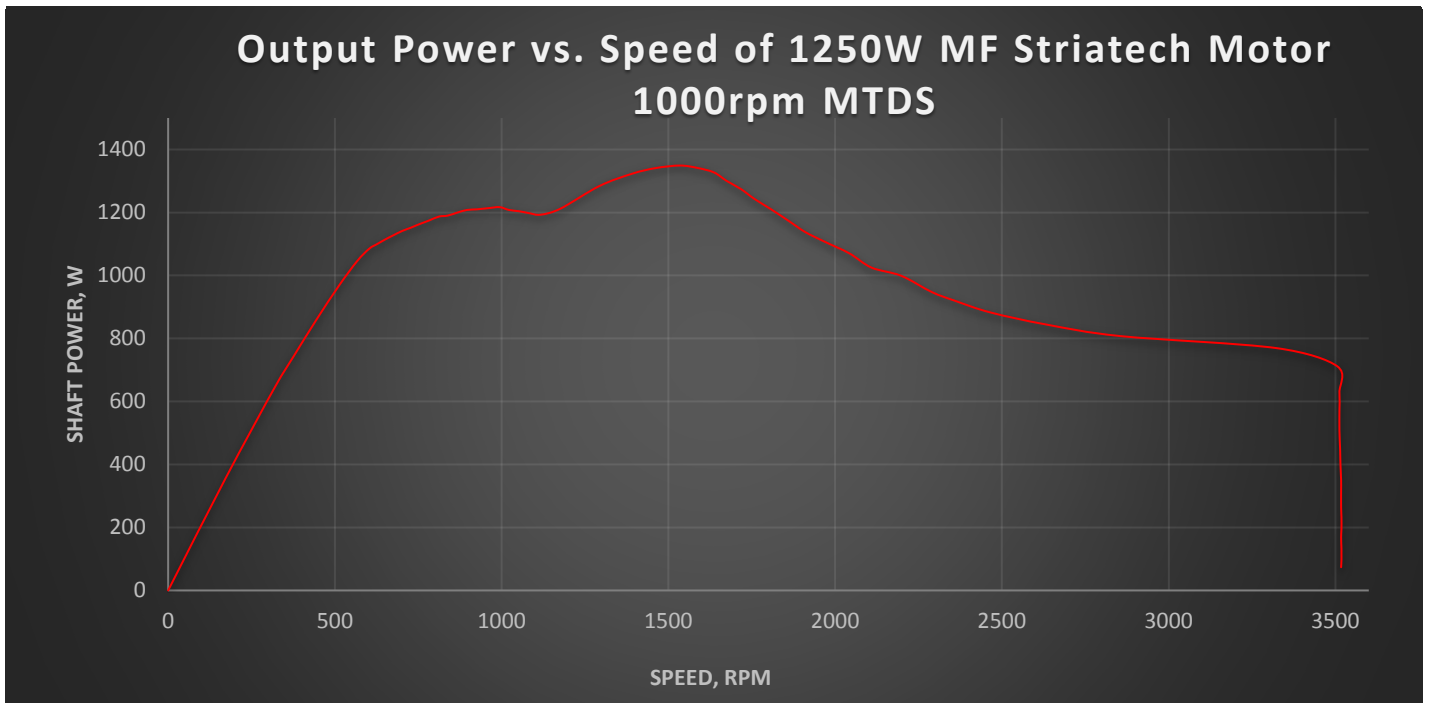
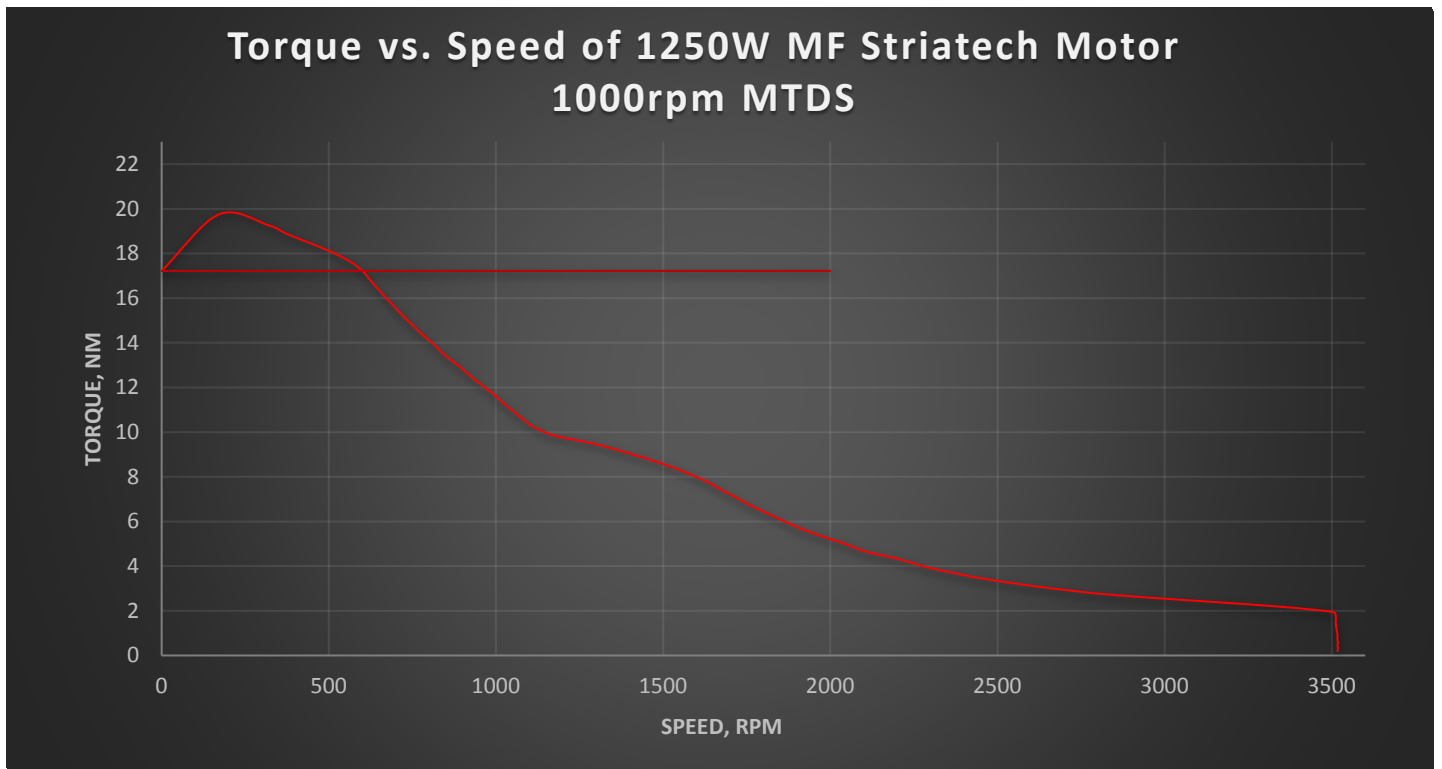

Torque Curve: 1800rpm Maximum Torque Delivery Speed (Base Speed)

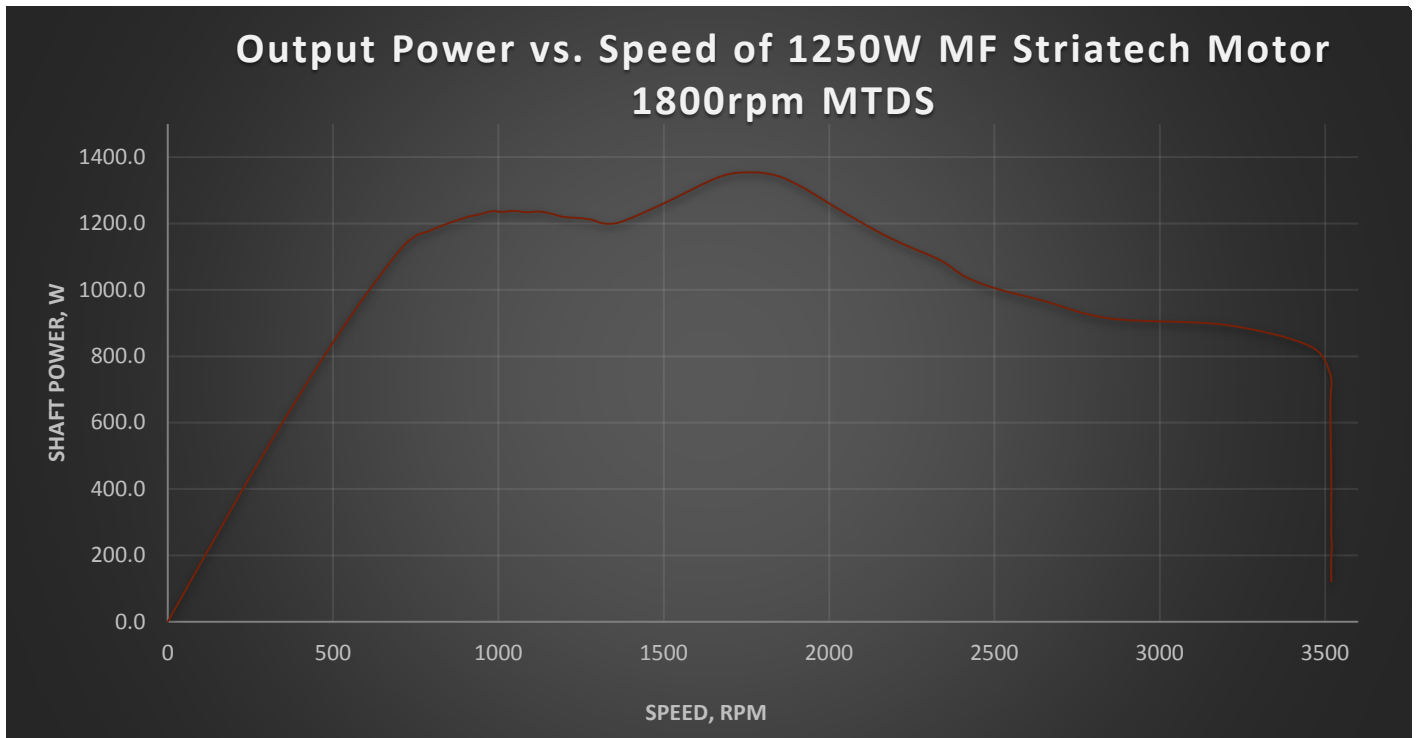
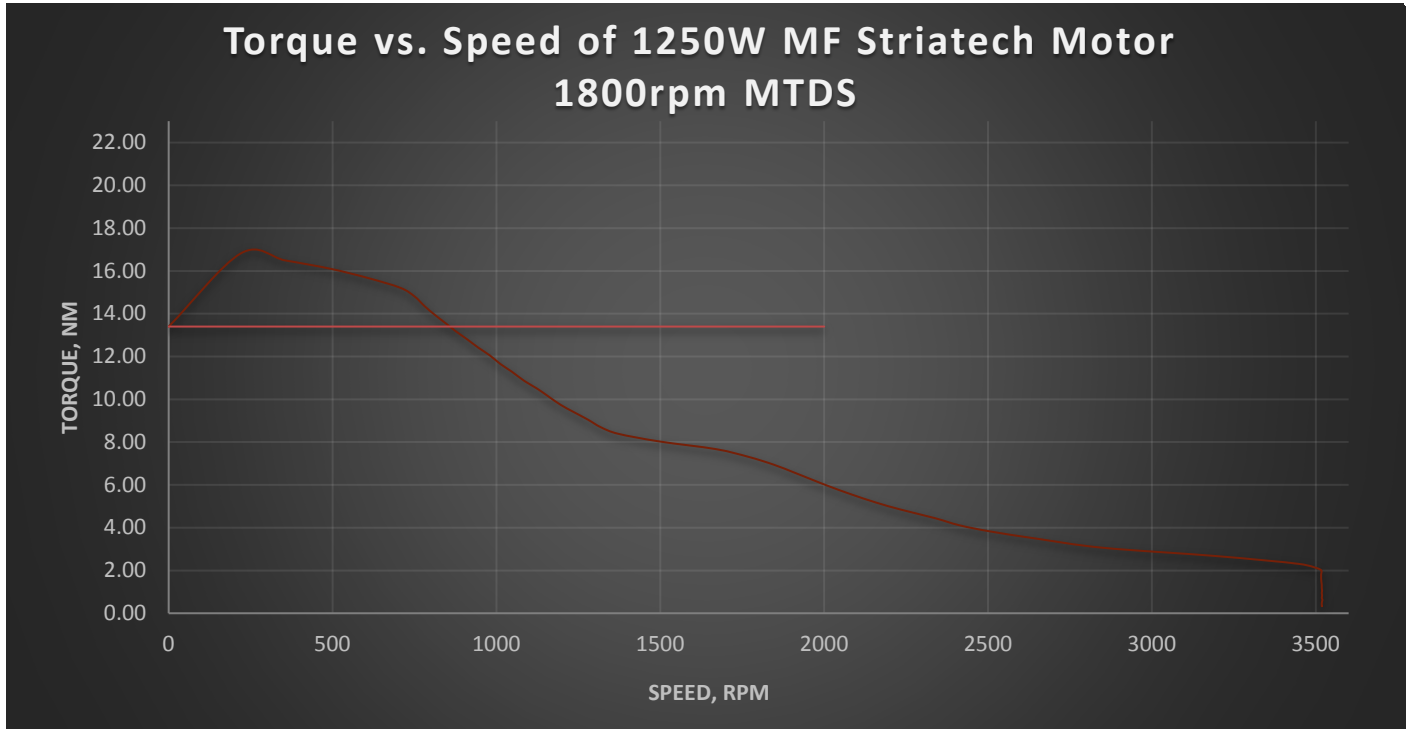

Sizes and Specifics for the MF Series

NEMA Flange Mount

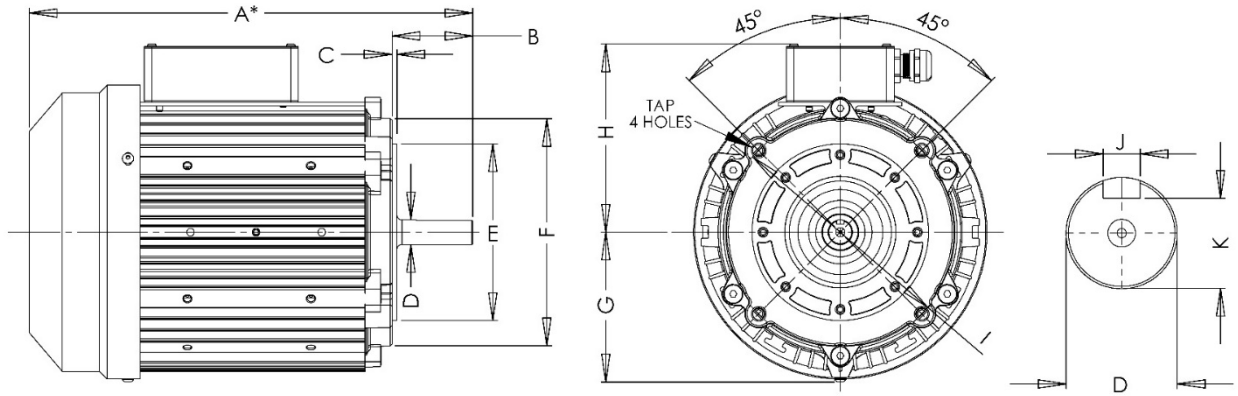

Model	Power (W)	HP	Frame	RPM Range	A* Approx., mm	B in	C in	D in	E in	F in	G in	H in	I in	J in	K in	Tap Size
	1250	1.67	NEMA	50-5500	11.311	2-1/16	1/8	5/8	4-1/2	5-11/14	3.814	4-2/5	5-7/8	3/16	33/64	3/8"-16
Extended Shaft	1250	1.67	NEMA	50-5500	11.311	2-1/16	1/8	5/8	4-1/2	5-11/14	3.814	4-2/5	5-7/8	3/16	33/64	3/8"-16
Reduced Shaft	1250	1.67	NEMA	50-5500	11.311	2-1/16	1/8	5/8	4-1/2	5-11/14	3.814	4-2/5	5-7/8	3/16	33/64	3/8"-16

Metric Flange Mount

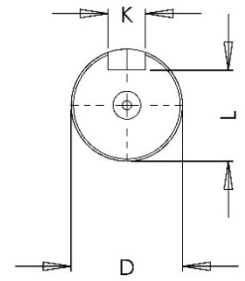
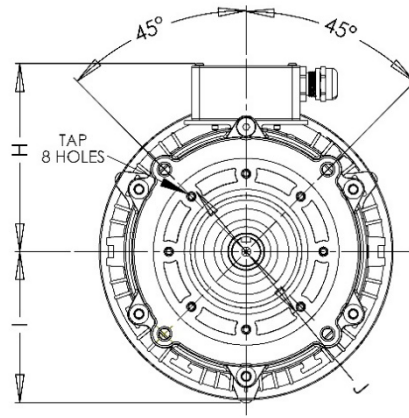
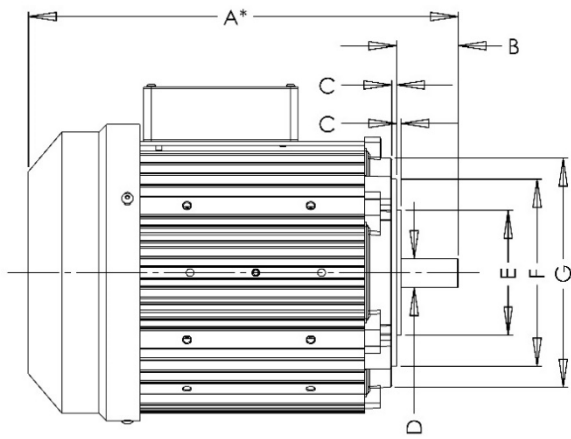

Model	Power (W)	HP	RPM Range	A* App. mm	B mm	C mm	D mm	E mm	F mm	G mm	H mm	I mm	J mm	K mm	L mm	Tap Size
	1250	1.67	50-5500	278	40	3	19	80	120	147	112	96.9	100	6	15.5	M6x1.0
Extended Shaft	1250	1.67	50-5500	278	40	3	19	80	120	147	112	96.9	100	6	15.5	M6x1.0
Reduced Shaft	1250	1.67	50-5500	278	40	3	19	80	120	147	112	96.9	100	6	15.5	M6x1.0

Torque Curves for the 2200W MF Series Motor

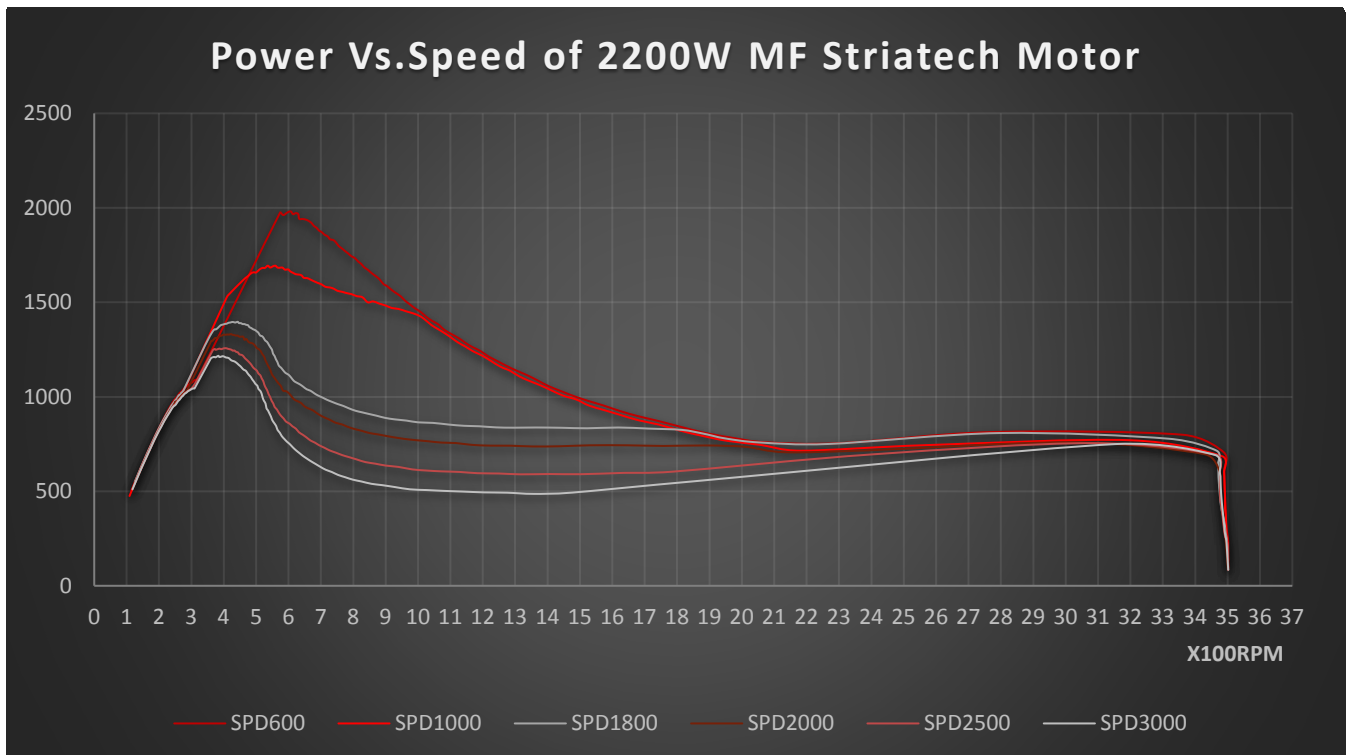
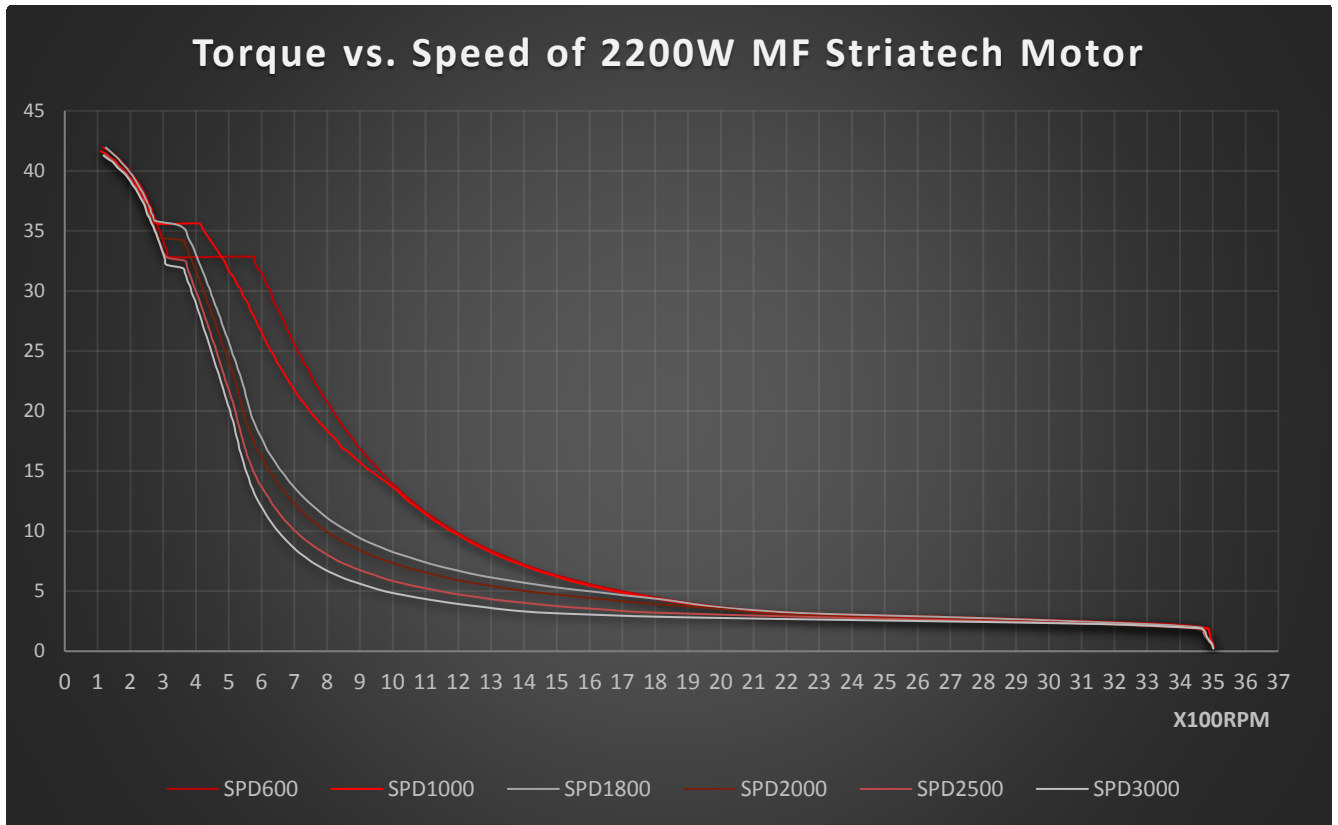

Case Study: The Drill Press

Problem:

Traditional drill press technology required a great deal of work in order to ascertain enough power to complete a job. This has resulted in major issues with safety, reliability and efficiency.

Society is fairly well-equipped with technology that keeps them safer and tools that helps them save time. However, the world of power tools, lags dramatically behind other industries in terms of technological breakthroughs.

This can be seen in the hundreds of catastrophic injuries sustained as documented by the U.S. Department of Labor's Occupational Safety and Health Administration.

A query for "drill press" under their incident file search shows more than 130 cases with various injuries, including amputated fingers, fractures and lacerations.



Evidence of Safety Issues in Traditional Drill Presses

Employee Sustains Amputation Of Two Fingers On Drill
Employee'S Thumb Is Amputated By Drill Press
Employee'S Fingers Are Amputated By Drill Press
Employee'S Finger Is Amputated By Drill Press
Employee'S Finger Is Amputated By Drill Press
Employee'S Arm Is Fractured In Rotating Shaft Of Drill Press
Worker Injures Finger On Drill Bit Flutes
Employee'S Finger Is Amputated When Caught By Drill Bit
An Employee'S Thumb Is Amputated While Using A Drill Press.
Employee'S Index Finger Is Amputated By Drill Press
Employee'S Glove Is Caught In Drill Press, Receives Fracture
Employee'S Thumb Is Amputated By Drill Press
Employee Is Injured By Drill Press, Finger Is Amputated

This is just a sample of the documented incidents involving drill presses that don't have Striatech motors and safety features. OSHA provides a full report on these types of injuries as they happen in the workplace, and most pertain to either belt changes or loss of control of the machine. OSHA does not consider the number of trips to the Emergency Department taken by woodworking and metalworking hobbyists. As non-professionals, the incidence of injuries is anecdotally high.

The NOVA Voyager Drill Press, equipped with the Striatech motor, is sold at a price point that amateurs can afford. Due to the motor's ability to sense load and balance, and to come to an immediate stop due to its electronic braking feature, the Voyager drill press offers safety features that can limit these tragic incidents and allow its users unparalleled safety.

Apart from the safety issues, traditional drill press systems require management of belts that help the operation of the device in terms of speed modification. This is a major time-loss for those who are trying to find the right speed for their drilling. These belt adjustments, even for the most experienced operator, can slow a project dramatically.

Solution:

By implementing the Striatech motor into a thoughtfully designed standing drill press, NOVA has created a tool that will revolutionize workshops across the world. This tool is branded as the NOVA Voyager DVR.

When applied to the drill press, a Striatech motor gives the user built-in safety features, including a highly visible emergency stop button, load sensing capabilities that allow the motor to adjust appropriately, slow start speeds to help the operator ease in to the workpiece, and more. These key features aid in limiting and preventing injuries that are common in a more traditional drill press.

Along with these safety features numerous convenience features complete this next generation drill press. With the variable speed motor, the user can easily adjust speed through the digital interface. The user can also take advantage of speed settings, and utilize the speed recommendations offered based on the bit and the material being drilled. There are no belts to change – speed adjustments are instantaneous.

Conclusion:

Striatech customer, NOVA Woodworking, has utilized the power of the DVR motor to improve the user experience. By making it easier to change speeds by removing the belt-changing process, use of the drill press became far more accessible to more users.

With the Striatech motor's smart technology, the standard drill press becomes far easier and safer to use. Plus, drilling is faster and more efficient. With such a powerful drill, it could potentially be utilized in additional applications, such as for metalworking.

User Experience

Voyager owner Sean Murray posted to NOVA's Facebook page with the following:

"I have used it for many applications from high speed polishing steel with a sanding mop to drilling and tapping 5mm holes in 1/4" plate steel so cool to watch this tool cut threads in steel. Next week I will have a bunch of wood tap handles to do where I'll drill a 1\2" hole followed up with a brass insert, I played around setting this job up a couple of weeks ago the user set depth setting was very helpful for screwing in the brass inserts to the correct depth.

Another job that I do requires a 2" hole almost 6" deep in end grain wood and the Voyager handles it like a champ amazing how it just applies more torque to maintain the bit speed as I applied pressure to the handle.

I bought this drill press to replace my Powermatic 2800b and the Voyager wins hands down in every department I would have just broken bits if I tried tapping steel with the 2800b, not to mention the belts slipping if I needed any sort of torque with a bigger bit. I bet this motor would be nice in a table saw!"



The DF Series

In search of a more economical motor solution? Striatech's DF series provides a lower-cost, stripped down version of the MF series.

These motors share similar basic bones and components, but the DF Series has a simplified controller to run the switched reluctance technology.

Users of a DF motor will experience the same limited maintenance and reliability offered in Striatech's other lines. With no brushes, belts or pulleys, the DF motor is a simple solution for any basic application.

With a vibration-free, quiet motor, you'll see what an advantage Switched Reluctance motors have over traditional AC and DC motors.



Contact Striatech for complete pricing information on the DF Series.

Email: sales@striatech.com | Phone: 727.202.9932

The MM Series

The MM Series is one of Striatech's most economical, compactly sized motors. Despite its small size, it's a powerful motor that's ideal for smaller applications, including pumps and fans.

The MM Series is small in size but big in power. Coming in at 60W, this motor offers high-end intelligent control, which can be stripped down to basics for simple applications or boosted to the top of its capabilities for highly intelligent applications.

This is the newest member of the Striatech Switched Reluctance motor family, and it far exceeds the capabilities that its low price suggests. In line with its paramount intelligence features, its quietness and reliability are on par with the other models of the Striatech motor line.

MM is a Switched Reluctance motor with the simplest construction – including no permanent magnets, no brushes, belts and pulleys and its composition of least moving parts – which keeps its production cost down at equally advanced capabilities as in the MF series. The MM delivers big features in a small package.



While the DF and SF series are simplified versions of the MF motors operating with less magnets firing the MM is basically a smaller version of the MF that reaches comparable results. The firing of multiple magnets delivers a lot more starting torque and allows maximum efficiency due to its fluctuation of power being much more controlled as in the simplified version. The only main difference between the MF and the MM besides their size is their ratio. The MF has a 12/8 configuration which means that the rotor has 8 teeth and the stator 12 teeth while the MM's rotor features 6 teeth and its stator 8 teeth.

Contact Striatech for complete pricing information on the MM Series.

Email: sales@striatech.com | Phone: 727.202.9932

Human Machine Interface

Our brains have nerves that are wired to our muscles that help make movement happen. Our motors have the Human Machine Interface.

Powered by an STM32 Microcontroller, this control board offers the ideal programming environment for development and prototyping with the Striatech motor drive. With the help of its 32-bit microcontroller, the HMI allows for fast processing while offering control and monitoring of the motor.

Technically speaking, the microcontroller has a 72MHz max CPU and 128kb flash memory, 20kb RAM, three 16-bit timers and two ADC conversion units. It's compatible with several developing environments, and has one reset output, 12 programmable I/O and nine expanded I/O. With the expanded I/O port, you can add sensors or other I/O to the HMI.

Add in USB and CAN compatibility, and it's a highly customizable, developer-friendly tool. Plus, it is capable of pairing with a wireless remote.

HMI Options

Standard HMI:

The standard HMI is a high-end, feature-intensive board that provides incredible precision and high-end motor function. This is the equivalent to the "fully-loaded" vehicle – it comes complete with vital components that create a smooth user experience. This information in the HMI is then used to control the motor based on pre-programmed metrics pertaining to those conditions.

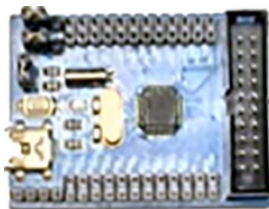
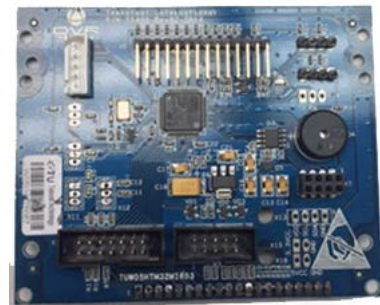

Low-Cost HMI:

This matchbook-sized board maintains the high precision that is required to run the motor. However, some of the intelligent components have been removed. This limits the motor's ability to interact with the environment and relevant conditions, and is useful for those looking to simply run a motor with the torque requirements offered by all Striatech motors.

Case Study:

Modernizing the Wood Lathe

Problem:

The wood lathe is a tool utilized for woodturning projects, including creating bowls, pens, spindles and much more – often resulting in beautiful, artistic work.

However, in a world overwrought with smart phones, smart homes, smart cars, etc., the woodworking world was still living in the technological dark ages. Turners were burdened by inaccurate speed selection, excessive vibration and noise from the old AC motors that powered their lathes, and a number of safety risks each time they went into their workshops.



Solution:

As a longstanding innovator in the woodworking world, NOVA began to formulate a method for a better turning experience. The result was the Striatech motor and controller, which allowed users to choose a specific speed (and save eight different “favorite” speeds), and utilize the machine’s recommendations based on the workpiece’s size and shape.

The lathe is fully equipped with safety features, made possible by the motor’s ability to sense load changes and apply electronic braking. Not only that, but the lathe can be password protected to keep children’s hands away from it unless supervised. But the most heralded change to woodturning, thanks to the Striatech smart motor, is the quiet, vibration-free experience.

User Experience:

After implementing a plug-and-play replacement motor to the NOVA 1624 wood lathe, customers flocked to use this incredibly quiet, user-friendly machine. The motor is so simple to use customers are able to swap their old lathe motor out for the Striatech motor without professional help. And once the lathe is up and running, the positive feedback kept flowing. NOVA was so inundated with orders for the replacement motors, it could hardly keep them stocked on the shelves. This was changing the face of woodturning – making it a more enjoyable experience.

The motor has been a successful component of the DVR XP Lathe, which reviewers lauded for its ease of use and smooth turning experience.



NOVA 1624-44 (AND NOVA DVR-XP)

These two are identical except for the headstock and drive mechanism. The 1624-44 is an excellent basic lathe and the author's choice for best value. The DVR (inset) has an excellent electronic speed control. Both lathes are light and will benefit from having a base with plenty of ballast.

In a head-to-head tool test, published in Fine Woodworking Magazine, a reviewer noted the many positives this motor offered the lathe:

Stepping it up. The Nova 1624-44 has eight speeds, set by shifting the drive belt between pairs of pulleys with the lathe stopped. But for many turners, this is all the speed control they will need.



"The unique Nova DVR integrates the motor and headstock; it has no drive pulleys. This makes for an extremely rigid spindle and very smooth, quiet operation."

Make Connections

Sales or Product Inquiries:

sales@striatech.com

General Information:

info@striatech.com

Phone Number:

+1 (727) 202-9932

Visit Our Website/Purchase Motors:

www.striatech.com

Like Us on Facebook:

www.facebook.com/striatech



where mind meets motor