

OLYMPUS®

AX70

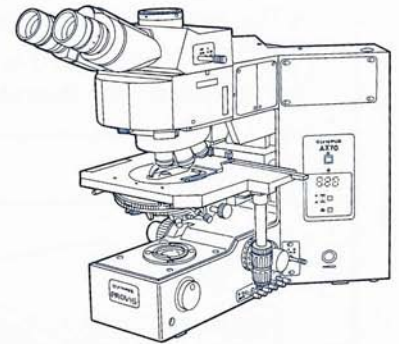

INSTRUCTIONS

AX70

TRUE RESEARCH SYSTEM MICROSCOPE

2 Restrictions when Using Additional Intermediate Attachments

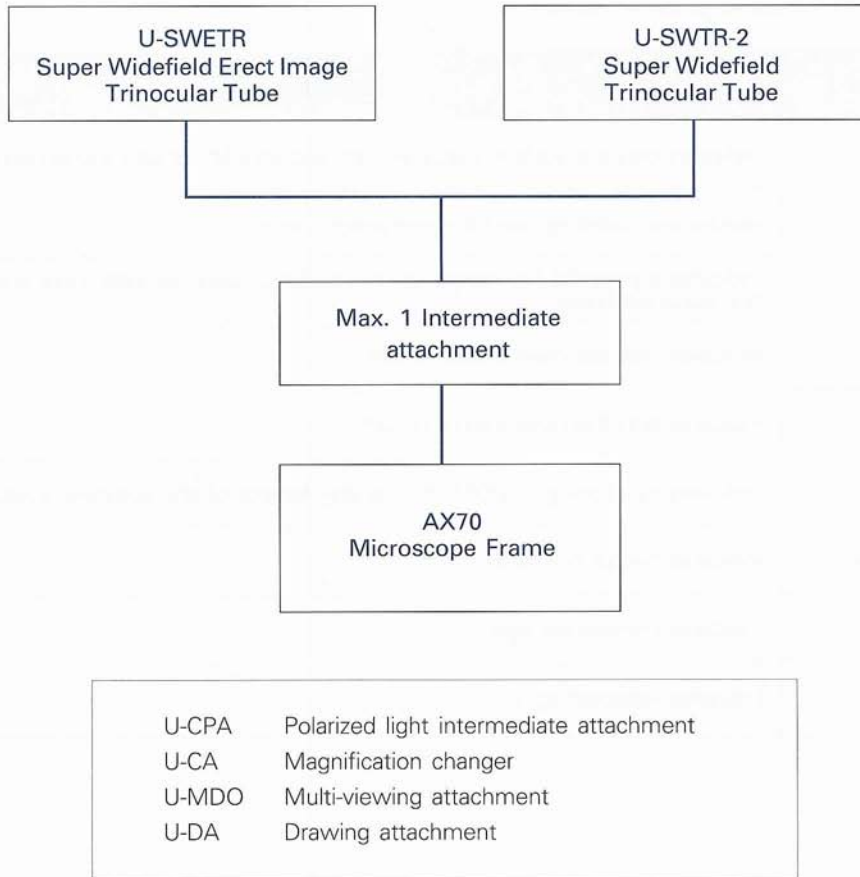









3 Maintenance and Storage

1. Clean lens by wiping gently with gauze. To remove fingerprints or oil stains, wipe with gauze slightly moistened with xylene or a mixture of ether (70%) and alcohol (30%).
★ Since both ether and alcohol are highly flammable, be careful these chemicals away from open fire and potential sources of electrical sparks, such as switching of main switches ON/OFF.
2. Do not attempt to use organic solvents to clean the non-optical components of the microscope (especially plastic parts). To clean these, use a lint-free, soft cloth lightly moistened with a diluted neutral detergent.
3. Do not disassemble any part of the microscope.
4. When not using the microscope, keep it covered with the provided dust cover.

4 Safety Symbols

The following symbols are found on the microscope. Study the meaning of the symbols, and always use the microscope in the safest possible manner.

Symbol	Explanation
	Indicates that the surface becomes hot, and should not be touched with bare hands.
	Before use, carefully read the instruction manual.
	Indicates a potential fire hazard; when replacing fuses, be sure replacement fuse is of the specified rating.
	Indicates that the main switch is ON.
	Indicates that the main switch is OFF.
	Indicates functioning ON/OFF for standby remote of the sub-main switch.
	Indicates output connector.
	Indicates transmitted light.
	Indicates reflected light.

5 Caution

If the equipment is operated in a manner not specified by this manual, the safety of the equipment may be impaired. In addition, the equipment may also be damaged. Always operate the equipment as outlined in this instruction manual.

CONTENTS

1	NOMENCLATURE	1	1
2	ASSEMBLY	2	2
	2-1 Assembly Diagram.....	2	
	2-2 Detailed Assembly Procedure	3	
3	CONTROLS	9	3
4	SUMMARY OF OBSERVATION PROCEDURES	12	4
5	USING THE CONTROLS	14	5
	5-1 Base	14	
	5-2 Stage.....	18	
	5-3 Observation Tube.....	20	
	5-4 Condenser	22	
	5-5 Focusing Adjustment Knobs	24	
	5-6 Immersion Objectives.....	25	
	5-7 Photomicrography.....	25	
6	OBSERVATION METHODS	27	6
	6-1 Phase Contrast Observation	27	
	6-2 Simple Polarized Light Observation	28	
	6-3 Nomarski Differential Interference Contrast Observation.....	28	
7	SPECIFICATIONS	31	7
8	OPTICAL CHARACTERISTICS	33	8
9	ERROR CODE CHART	34	9
10	TROUBLESHOOTING GUIDE	35	10

1 NOMENCLATURE

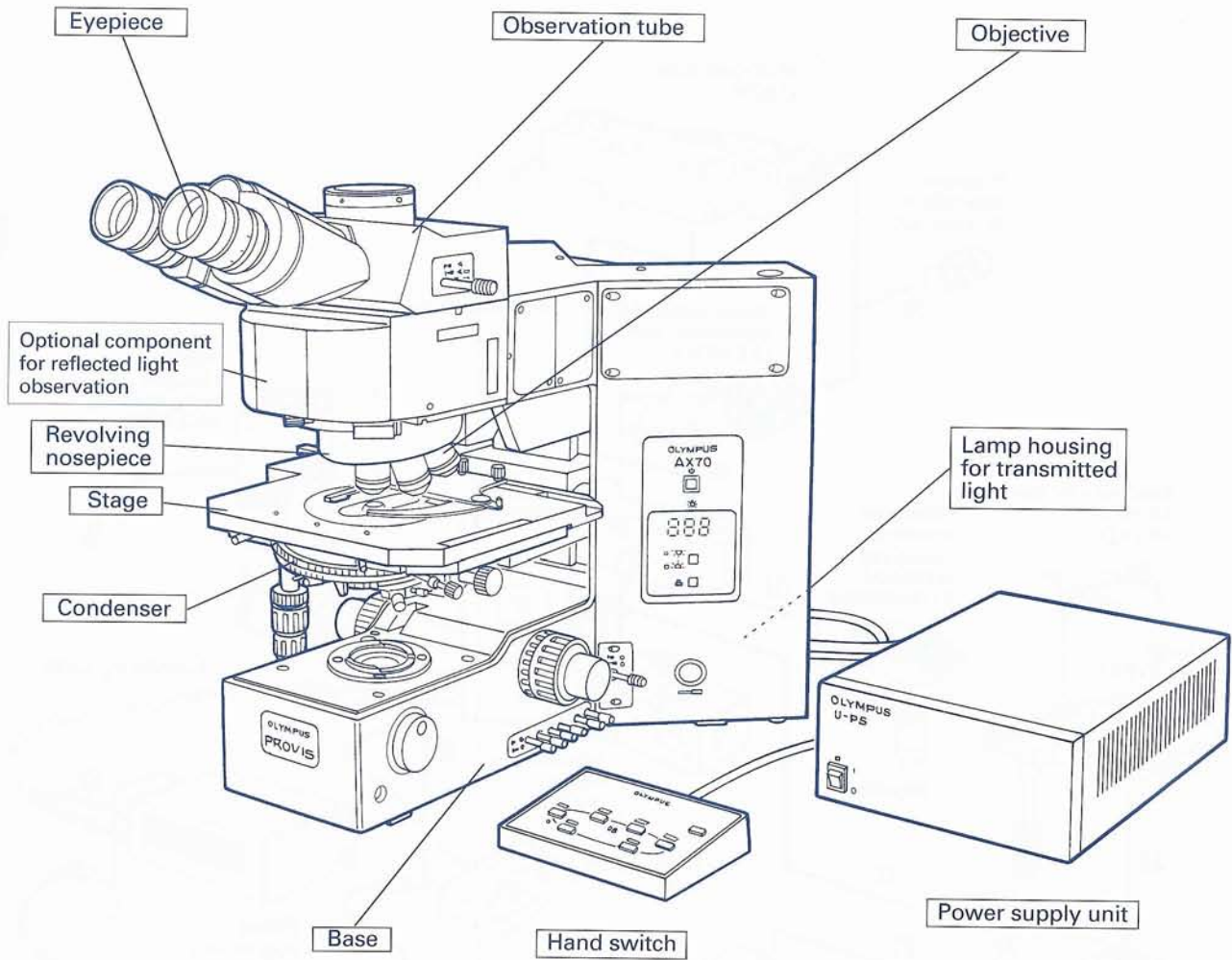

2 ASSEMBLY

2-1 Assembly Diagram

The diagram below shows how to assemble the various components. The numbers indicate the order of assembly.
★ When assembling the microscope, make sure that all parts are free of dust and dirt, and avoid scratching any parts or touching the glass surfaces.

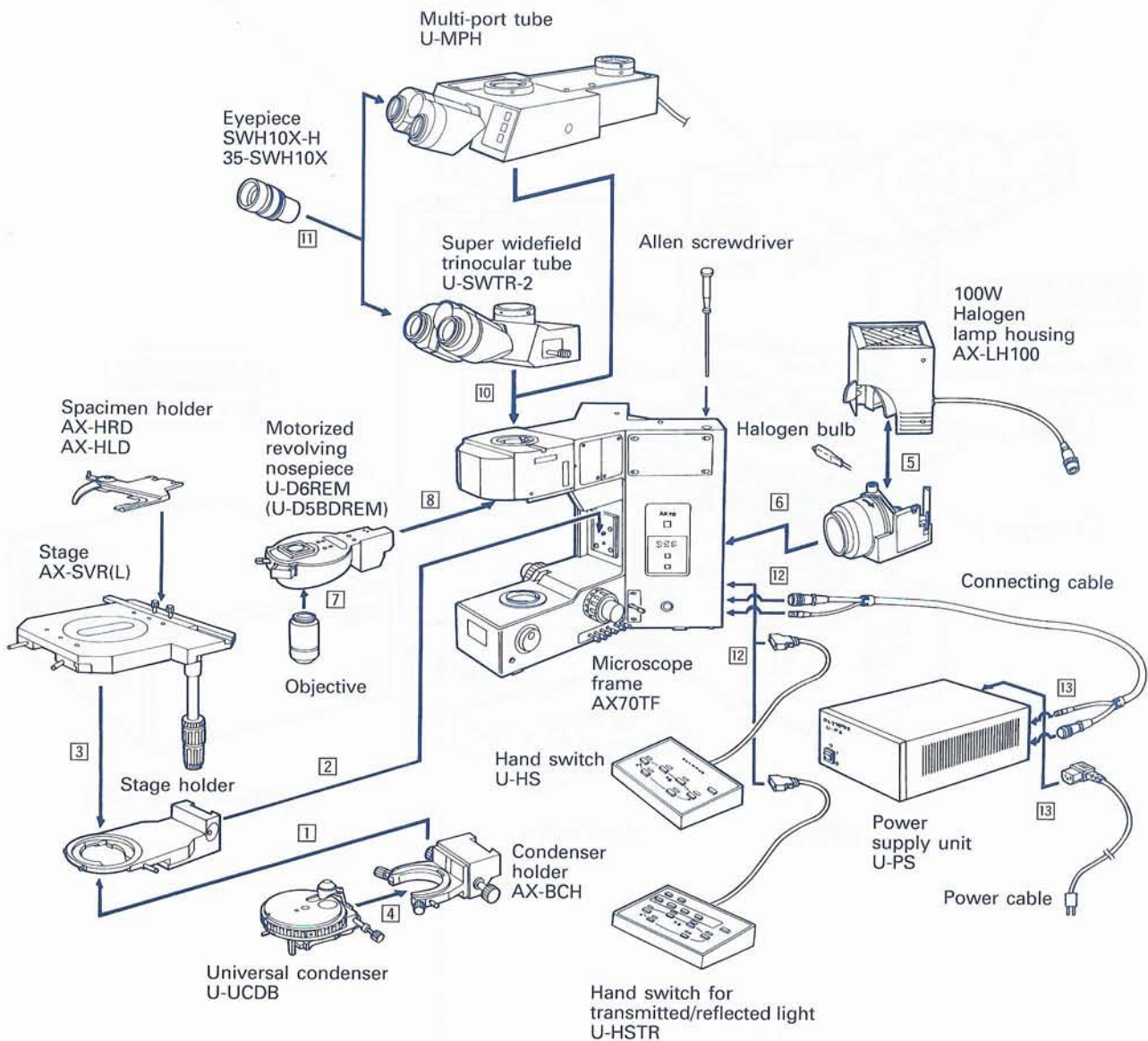

2-2 Detailed Assembly Procedure

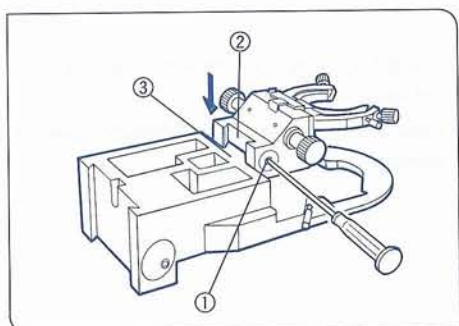

Fig. 1

1 Attaching the Condenser Holder (Fig. 1)

- ⊙ Turn the stage upside down for assembly.
- 1. Using the Allen screwdriver provided with the microscope, loosen the screw ① used to clamp the condenser holder.
- 2. Slide the condenser holder dovetail ② onto the stage dovetail ③ from below.
- 3. Using the Allen screwdriver, tighten the clamping screw ① again.

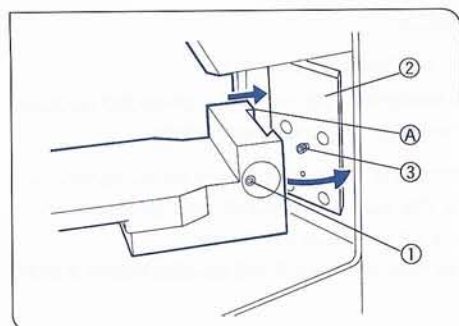

Fig. 2

2 Attaching the Stage Holder (Fig. 2)

- 1. Adequately loosen the stage holder fixing screw ① by Allen screwdriver attached to the microscope frame.
- 2. Mate the stage holder side A with the attaching dovetail ②, and then contact the fixing screw side to the attaching dovetail.
- 3. Lower down the holder gradually until it contacts with stopper screw ③.
- 4. Adequately tighten the fixing screw ① with Allen screwdriver.
- ★ Since the stage holder is heavy, be careful so that your hands or fingers may not be nipped when to install it. Attaching will be easier if the attaching dovetail ② is lowered down to the lowest position.

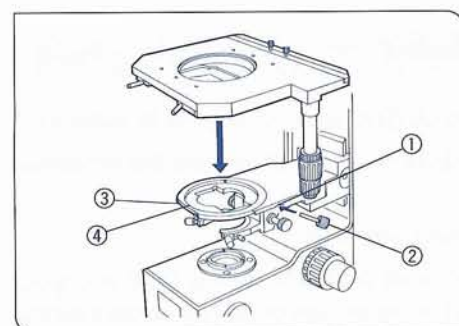

Fig. 3

3 Attaching the Stage Plate (Figs. 3, 4, 5)

- 1. Adequately loosen in a counterclockwise direction the centering screw ① (2 portions) on the stage using attached centering tool.
- 2. Next, loosen the locking screw ③ with dedicated Allen screwdriver (3 mm).
- 3. Align the front pun of stage holder ④ attached to the ring with the groove of stage, gradually insert the stage, and rotate the stage centering screw ① for a few rotations. Then tighten the locking screw lightly. (Fig. 3)
- 4. Remove the centering tools and keep them in the tool box.

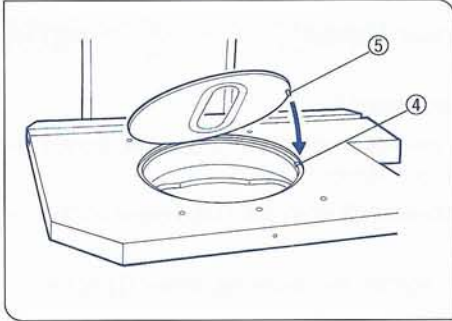

Fig. 4

Attaching the Stage Plate

Attach the stage plate by aligning the stage pin hole on the stage (4) with the guide pin (5) on the stage plate. (Fig. 4)

★ Handle the stage plate with care. Shock or impact may distort or destroy the levelness of the plate surface.

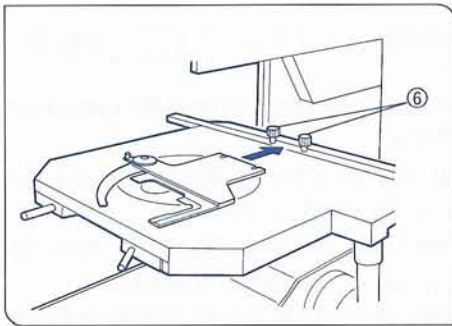

Fig. 5

Attaching the Specimen Holder

1. Loosen the specimen holder clamping screws (6).
 - ★ If the clamping screws are loosened too much, the threaded portions may interfere with the grooves in the specimen holder.
2. Insert the specimen holder from the front until it comes up against the stop. At this point, make sure the specimen holder clamping screws fit into the positioning grooves on the specimen holder.
 - ★ If the specimen holder is not fully inserted, it will be attached in a tilted position.
3. Tighten the specimen holder clamping screws. (Fig.5)

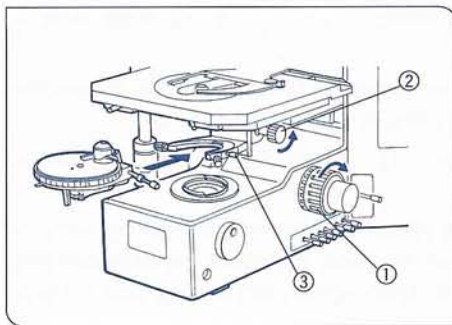

Fig. 6

4 Mounting the Condenser

(Fig. 6)

1. Turn the coarse adjustment knob (1) to raise the stage to its upper limit.
2. Turn the condenser height adjustment knob (2) to lower the condenser holder to its lower limit.
3. Loosen the condenser clamping screw (3).
4. When using the U-UCDB universal condenser or the U-SC swing-out achromatic condenser, swing the top lens out of the way before inserting the condenser.
5. Position the condenser with the scale markings in front, and insert it into the condenser holder fork as far as it will go.
 - ★ When mounting the U-UCDB universal condenser or the U-SC swing-out achromatic condenser, align the positioning pin at the back of the condenser with the groove in the condenser holder fork.
6. Tighten the condenser clamping screw, then raise the condenser to its upper limit.

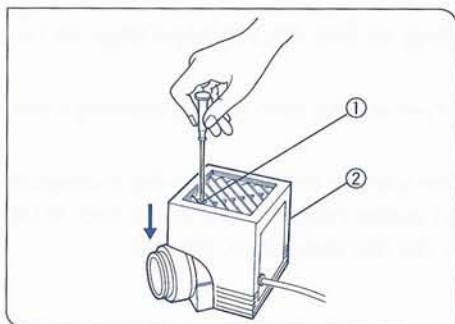

Fig. 7

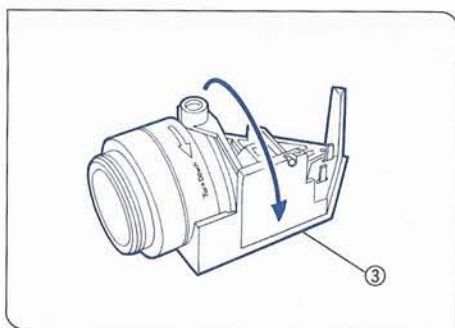

Fig. 8

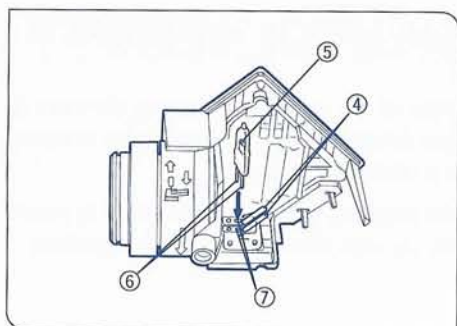

Fig. 9

5 Installing the Halogen Bulb

(Figs. 7, 8, 9)

Ⓢ Use only a designated 12V 100W/AL-L halogen bulb (Philips 7724)

1. Fully loosen the lamp housing clamping screw ① on top of the lamp housing cover with the provided Allen screwdriver.
2. Lift the lamp housing cover ② upward to remove it. (Fig. 7)

3. Turn the lamp socket ③ 90° in the direction indicated by the arrow. (Fig. 8)
4. Holding the bulb ⑤ with gloves or a piece of gauze, depress the bulb clamping levers ④ and insert the bulb pins ⑥ fully into the pin holes ⑦. Gently release the bulb clamping levers ④ to their original position to secure the bulb. (Fig. 9)

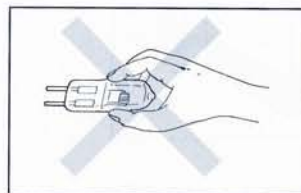

★ Do not touch the bulb with bare hands. If fingerprints are accidentally left on the bulb, wipe the bulb with a soft cloth.

5. Slide the lamp housing cover onto the housing base from above. Tighten the clamping screw ① while pressing downward on the cover. (Fig. 7)
- ★ Whenever you replace the bulb, first turn OFF the main switch on the power supply (U-PS) and wait for the bulb, lamp housing, and lamp socket to cool down.

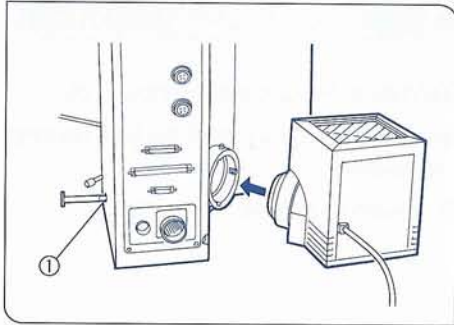

Fig. 10

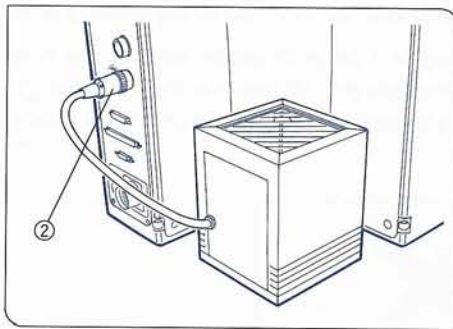

Fig. 11

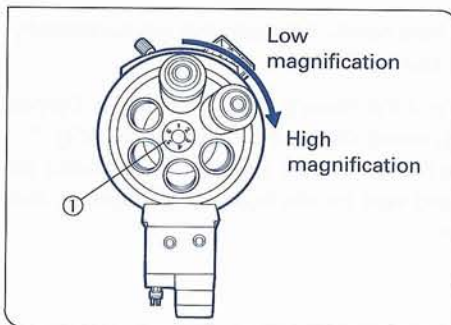

Fig. 12

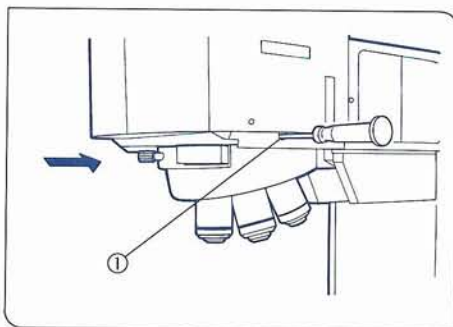

Fig. 13

6 Attaching Lamp Housing to the Microscope (Figs. 10,11)

1. Using the Allen screwdriver, fully loosen the lamp housing clamping screw ① on the microscope.
2. Insert the lamp housing collector unit into the opening in the microscope frame until it touches the lamp housing mounting collar on the back of the base (lower part), then tighten the clamping screw. (Fig. 10)
3. Plug the connecting cord into the power outlet ② marked ⚡. Make sure the connection is tight. (Fig. 11)

7 Mounting the Objectives (Fig. 12)

Mount the objectives in the order of the objective mounting numbers ① on the revolving nosepiece in such a manner that the magnification increases from low to higher powers in a clockwise direction.

- Ⓞ To secure smooth rotation of the revolving nosepiece, make sure to mount objectives evenly in all sockets; i.e. also mount rarely used objectives.

8 Mounting the Motorized Revolving Nosepiece (Fig. 13)

1. Turn the coarse adjustment knob to lower the stage all the way.
2. Using the Allen screwdriver, loosen the nosepiece clamping screw ① on the microscope.
3. Carefully slide the nosepiece along the dovetail, in the direction of the arrow, all the way in.
 - ★ When inserting the revolving nosepiece, make sure the connection between nosepiece and the microscope frame is tight.
4. Clamp the nosepiece by tightening the nosepiece clamping screw ①.

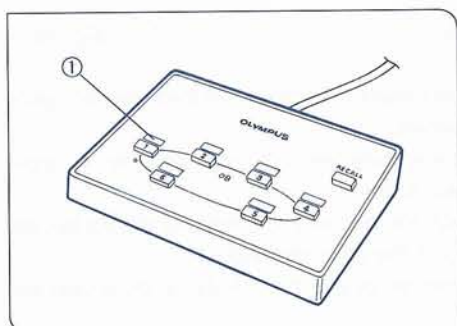

Fig. 14

9 Attaching Magnification Index Stickers (Fig. 14)

1. Attach the sticker corresponding to the mounted objective with the lowest power at the hand switch magnification index position ①.
2. Attach the appropriate stickers at the other index positions in such a manner that the magnification indication increases from low to higher powers in a clockwise direction.
 - ★ In the case of the quintuple nosepiece, skip the index position ⑥. Attach stickers with no magnification index at the numbers not used. (Fig. 15)

Ⓞ The adhesive strength of the sticker is designed so that the stickers can be easily moved by sliding them sideways.

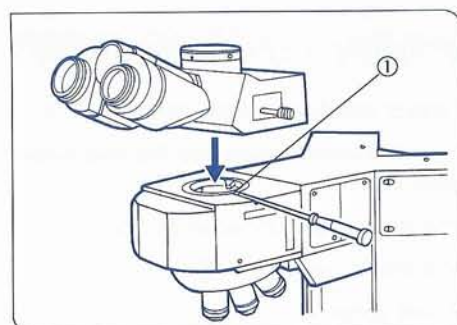

Fig. 15

10 Mounting the Observation Tube (Figs. 15, 16)

1. Using the Allen screwdriver, loosen the observation tube clamping screw ①.
2. Insert the circular dovetail mount at the bottom of the observation tube into the opening on the microscope frame, positioning the observation tube to point the binocular eyepieces towards the front. Clamp the observation tube by tightening the clamping screw. (Fig. 15)

★ If the direction of stage movement and the direction of image movement differs during observations, loosen the stage clamping screw ② slightly and adjust the stage ③ by rotating it, while observing the image. (Fig. 16)

★ Refer to page 30 for "Installation of Multi-port Tube".

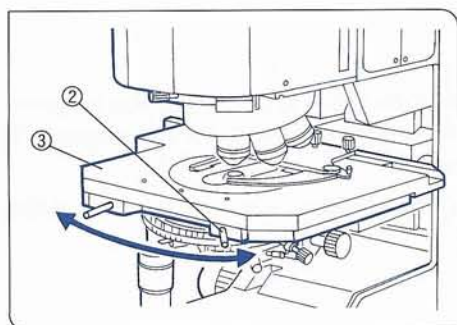

Fig. 16

11 Mounting the Eyepiece (Fig. 17)

Ⓞ Eyepiece mounting is performed in the same manner when the super-widefield erected image trinocular observation tube (U-SWETR) is used.

1. When employing a photoreticle eyepiece or any other eyepiece with a focussing front lens assembly, insert this eyepiece into the right-hand eyepiece sleeve. When doing so, make sure that the eyepiece positioning pin ① fits into the notch ② at the bottom of the eyepiece sleeve.
2. Insert the other eyepiece ③ into the left-hand eyepiece sleeve as far as it will go. Make sure that the eyepiece positioning pin fits into the notch at the bottom of the eyepiece sleeve.

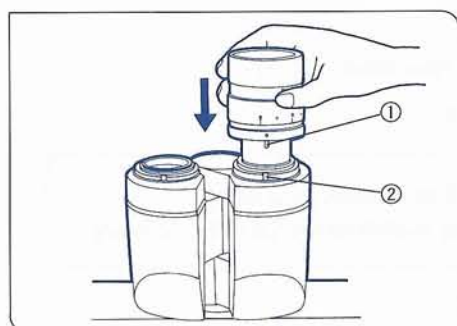

Fig. 17

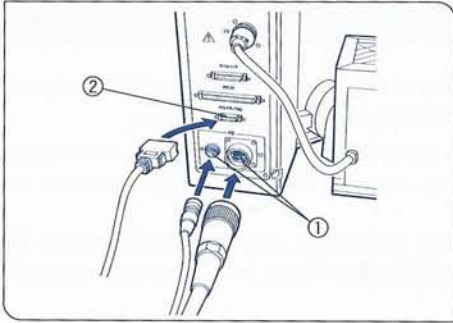

Fig. 18

12 Connecting the Cables

(Fig. 18)

★ The cables are easily damaged if bent or twisted. Never apply excessive force to the cables.

1. Insert the connecting cable's two multi-pin plugs firmly into the two input sockets ① on the microscope frame.
 - To connect the large plug, align the pins with the holes in the socket and push. Turn the clamping ring of the plug clockwise.
 - To connect the small plug, align the pins with the holes in the socket and push.
2. Insert the hand switch connecting cable into the multi-pin socket ② on the microscope frame.

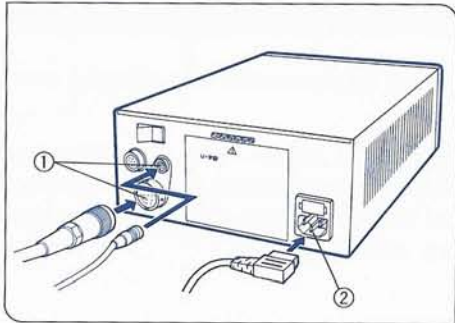

Fig. 19

13 Connecting the Power Supply

(Figs. 19, 20, 21)

★ Make sure that the U-PS power supply unit main switch ○(OFF).

1. Insert the connecting cable's two multi-pin plugs into the two output sockets ① on the power supply unit.
- Ⓞ Connect the plugs in the same manner as outlined in Section 12.
2. Insert the power cord plug into the AC receptacle ②.
3. Plug the power cord into the wall outlet.
4. Connect the power cord ground wire to the ground terminal on the wall outlet. (In the USA the ground wire is part of the power cord).

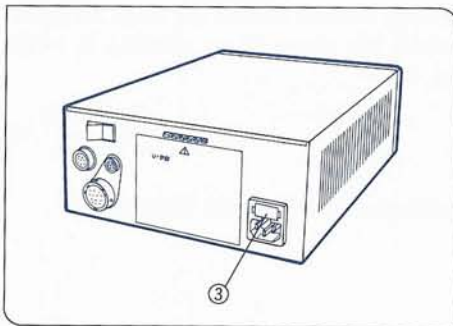

Fig. 20

Fuse Replacement

Ⓞ Before replacing fuses, set the main switch to OFF and unplug the power cord. (The power cord should be unplugged from the AC receptacle to allow removal of the fuse cassette.)

1. Remove the fuse cassette ③ by squeezing it at both sides and pulling outward. (Fig. 20)

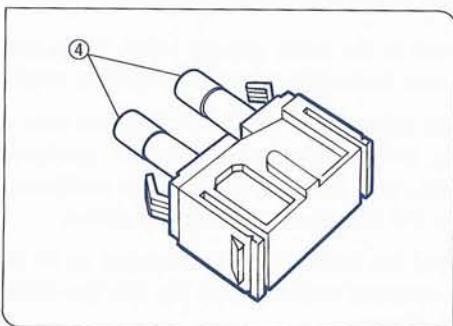

Fig. 21

2. Replace both fuses ④ with new ones. (Fig. 21)

★ Use only specified fuses.

Applicable fuse: 250V, 6.3A (Littelfuse 21506.3)
Time Lag High-Breaking Capacity, 2 fuses

3 CONTROLS

3 CONTROLS

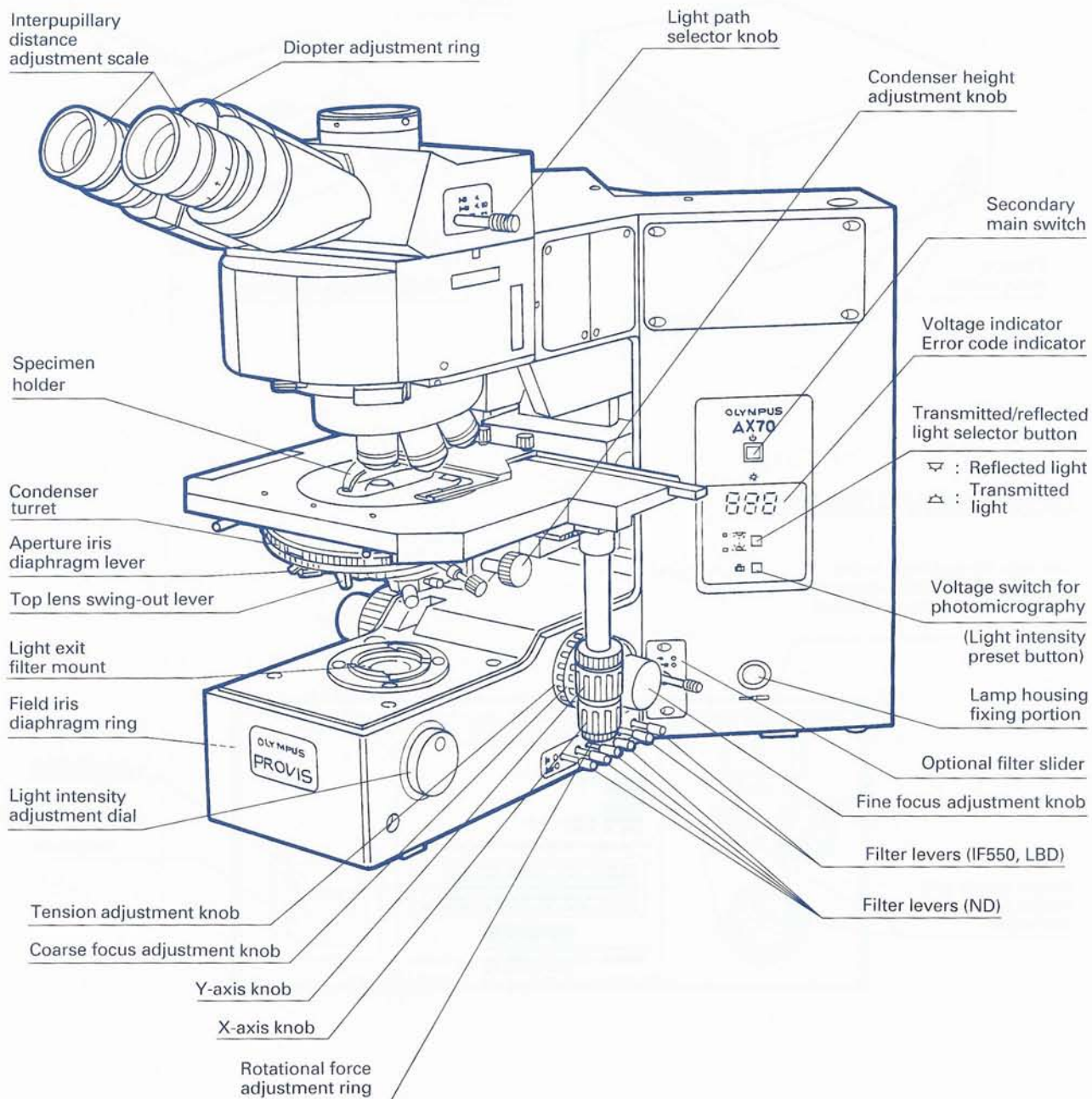

Power Supply Unit (U-PS)

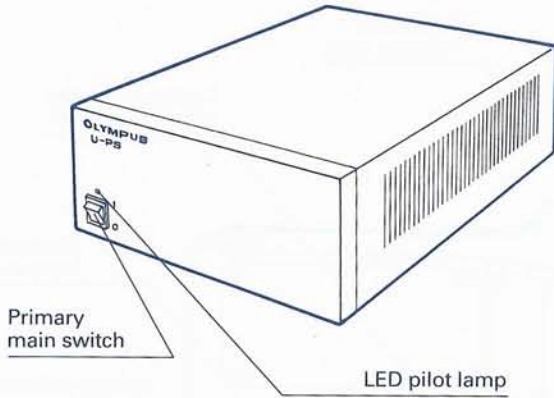

Hand Switch (U-HS)

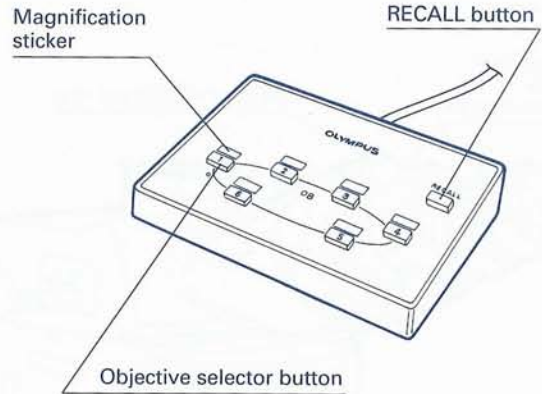

Power Supply Unit Rear Panel

Use with the switch set to this position (right-hand side depressed).
 ★ Never change the position of the switch.

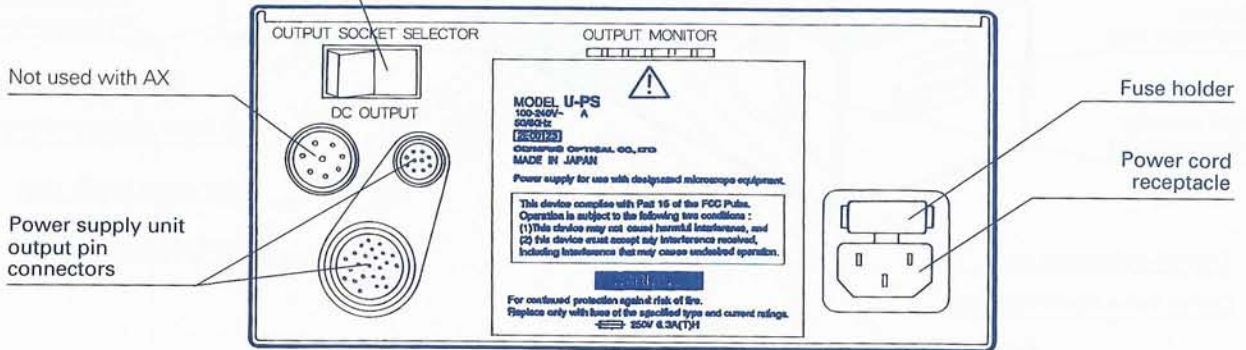

★ This power supply unit (U-PS) is for use with the AX70, AX80 series only.
 In no event will Olympus be liable for the safety of the equipment if the unit is used for any purpose other than its intended use.

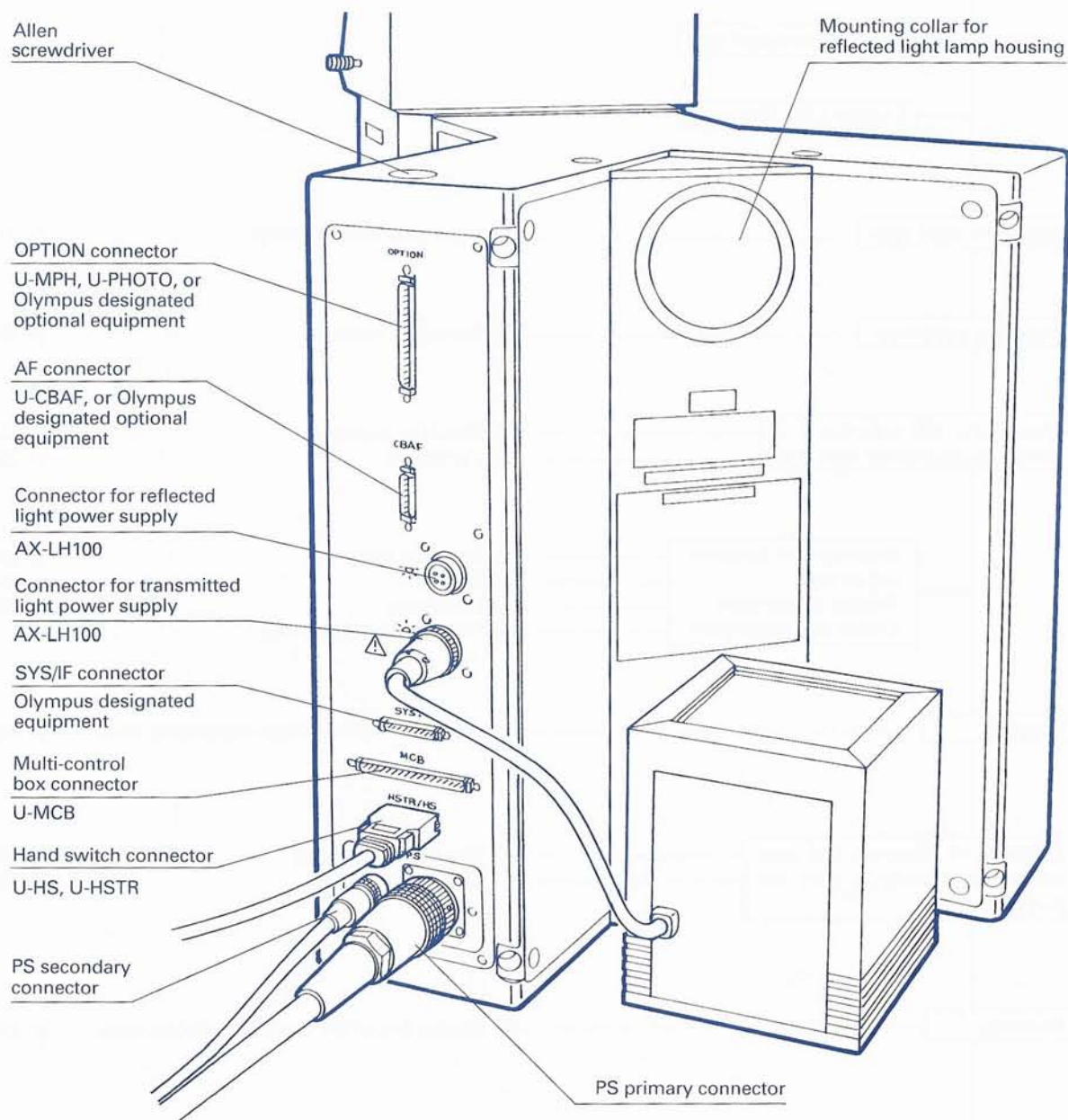

3

CONTROLS

- ★ Never connect equipment other than Olympus designated equipment to the connectors on the AX microscope frame.
- ★ The top surface of the lamp housing will be extremely hot. Ensure enough space around the lamp housing especially at the top and bottom, when to install the microscope frame.
- ★ Furthermore, make sure that no cables, etc. contact the lamp housing during operation.

4 SUMMARY OF OBSERVATION PROCEDURES

4

SUMMARY OF OBSERVATION PROCEDURES

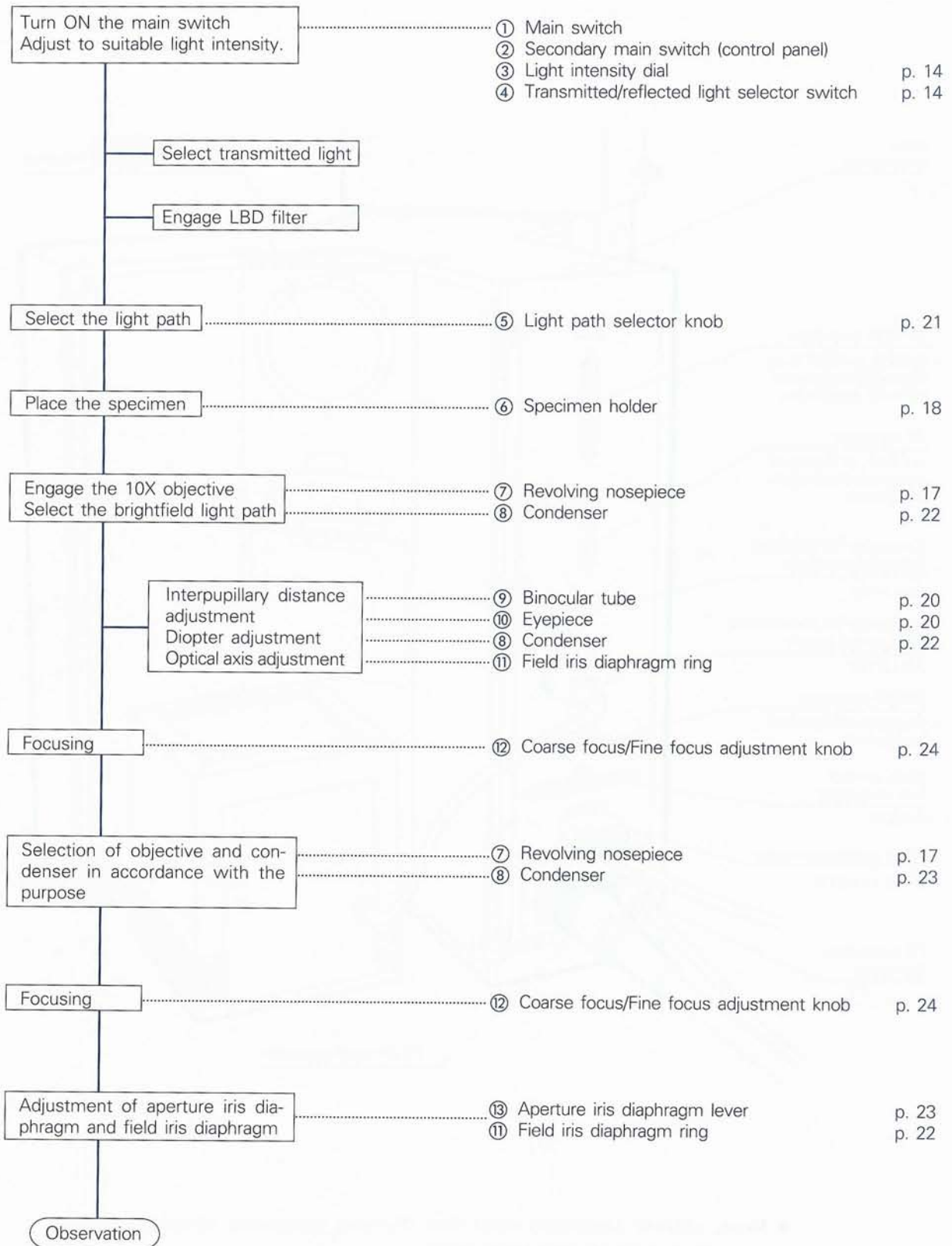

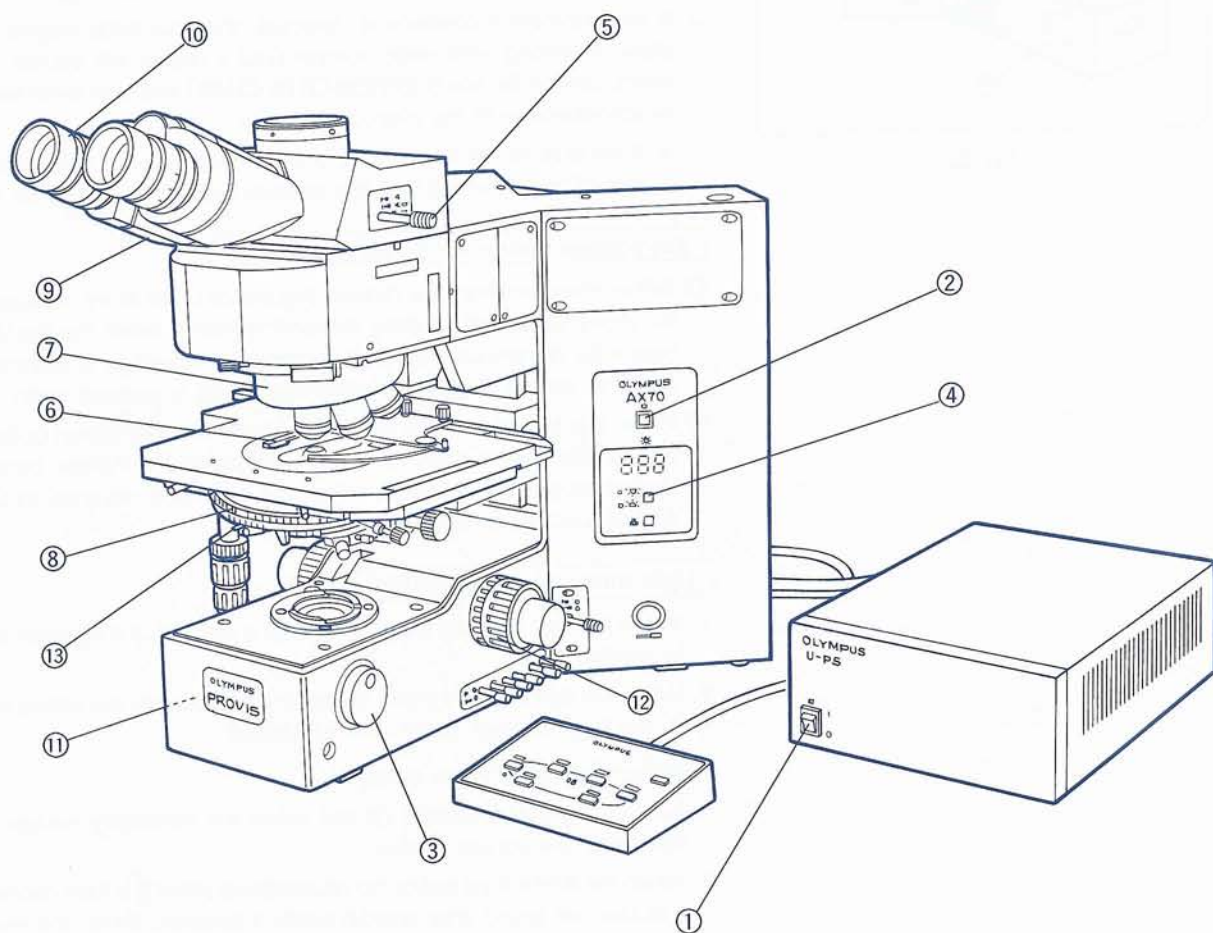

4 SUMMARY OF OBSERVATION PROCEDURES

5 USING THE CONTROLS

5-1 Base

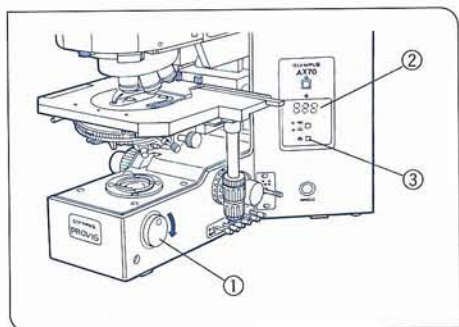

Fig. 22

1 Voltage Display/Error Code Display (Fig. 22)

1. Turning the light intensity dial ① clockwise increases the voltage, thus increasing light intensity.
 2. The voltage is digitally indicated on the voltage display ② .
 3. If any anomalous condition is detected, the error code display ② will show a blinking error code number (and a buzzer will sound). In this event, consult Section 9, ERROR CODE CHART and take remedial action in accordance with the instructions given.
- ★ If the bulb burns out, or a bulb is not mounted, the voltage display will blink (provided that the voltage indication is 2.0V or more).

Set-Voltage Button for Photomicrography

- ⊙ Before shipment from the factory, this button is set to 9V, as suggested for photomicrography. During photomicrography, when the Set-Voltage button for photomicrography ③ is pressed, the voltage is automatically set. This setting is released when the button is pressed again.
- ⊙ When this button can also be used as light intensity preset button (LP button), the switch then does not function as Set-Voltage button for photomicrography. However, when the setting is returned to 9V, its original function is restored.

Light Intensity Preset Button

1. When the light intensity preset button ③ is pressed, the previous setting is recalled.
2. When the light intensity preset button is pressed again, the setting returns to the original stage (which can be altered).

Setting the Light Preset Voltage

1. Turn the light intensity dial ① and select the necessary voltage while observing the voltage display.
2. When the Set-Voltage button for photomicrography ③ is kept depressed, a buzzer will sound after approximately 2 seconds. When the finger is removed from the button, the setting is completed.

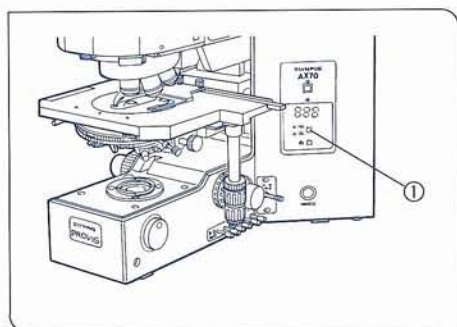

Fig. 23

2 Using the Transmitted/Reflected Light Selector Button

Press the transmitted/reflected light selector button ① to select transmitted light illumination ∇ .

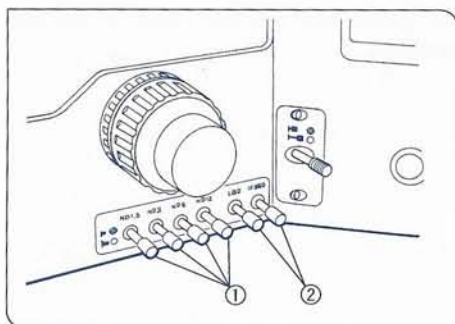

Fig. 24

3 Use of Filters

(Figs. 24,25,26,27)

Use filters as required for the observation.

Using Built-in Filters

(Fig. 24)

The following filters are built into the base of the microscope. These filters can be engaged and disengaged using the levers arranged in block ① and ②.

	Filter	Application	
①	ND1.5	Filter for adjustment amount of light	Transmission ratio 1.5%
	3		* 3%
	6		* 6%
	12		* 12%
②	LBD	Filter to convert the color temperature	
	IF550	Filter to increase contrast during B&W observation (green)	

- When the filter lever of the required filter is pushed in, the filter is placed in the light path. At the same time, the previously engaged filter is removed from the light path.
- To engage multiple filters simultaneously, press in the corresponding levers at the same time.

< How to Gradually Reduce the Light Intensity >

When using one ND filter, insert the front side filter from the inner side. When two or more filters are used, it is easier to insert adjacent two filters (or 3 filters) from the inner side.

(Example)

$$ND12 \rightarrow 6 \rightarrow 3 \rightarrow 1.5 \rightarrow \frac{12}{6} (0.72) \rightarrow \frac{6}{3} (0.18) \rightarrow \frac{3}{1.5} (0.045)$$

◎ To gradually increase the light intensity, reverse the above procedure.

1. Disengaging Block ① Filters

- To disengage an engaged filter(s), push an unengaged filter's lever halfway in.
- If all filters are engaged, push in the ND1.5 filter lever to disengage all the filters.

2. Disengaging Block ② Filters

- When the unengaged filter's lever is pushed halfway in, the engaged filter is removed from the light path.

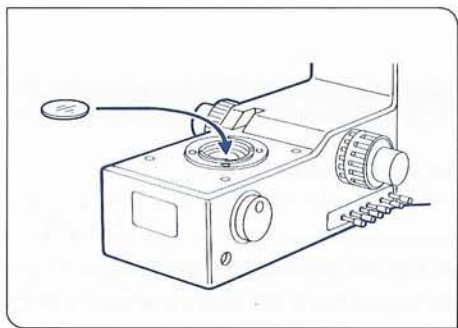

Fig. 25

Accessory Filter

(Fig. 25)

One 45 mm diameter filter can be placed in the filter holder on the light exit at the base of the microscope.

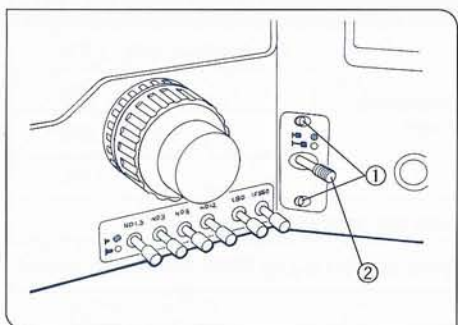

Fig. 26

How to Place Optional Filter

(Figs. 26, 27)

1. Using the Allen screwdriver, loosen the filter clamping screws ①.
2. Pull out the optional filter assembly by pulling at the filter lever ②. (Fig. 26)
3. Using tweezers, etc., remove the retaining ring ③ inserted into the filter holder. (Fig. 27)
4. Insert a 32 mm diameter filter (max. 4 mm thick).
5. Return the optional filter assembly to its original position.
6. If the filter is less than 2.7 mm thick, insert also the retaining ring ③.

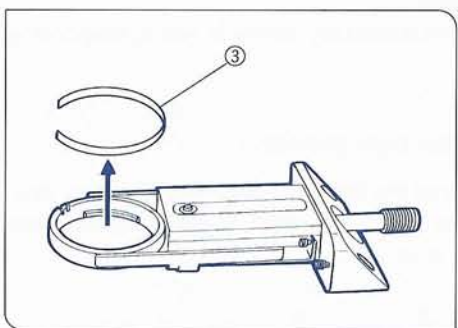

Fig. 27

Filter designation	Application
32FR	Frosted filter
32FF	Didymium filter
32IF436	Enzyme/Antibody labelling filter
32LBT	Light balancing filter

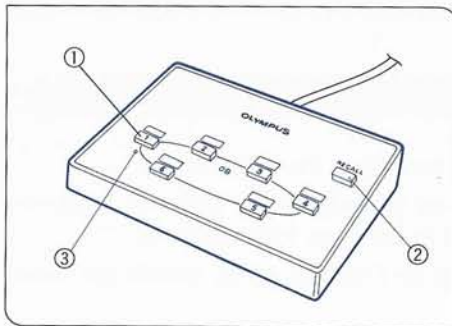

Fig. 28

4 Using the Hand Switch (U-HS)

(Fig. 28)

Objective Change

★ If the objective is changed while the stage is raised, the objective may impinge on the specimen. Focusing, starting with the low power objective and proceeding in the order of low to higher powers, should only be performed at the initial setting before use, and the parfocalizing distance should always be retained.

When the objective selector button a corresponding to the objective to be used is pressed, the objective moves into the light path. (In this example, the [2] button is pressed.)

- ★ If the revolving nosepiece misses the click-stop, the LED of the magnification indicator will blink and the revolving nose-piece will continue to move. In this event, press any of the buttons.
- ★ If the nosepiece connector is disconnected, the hand switch magnification indicator will blink.
- ◎ When the RECALL button ③ is pressed, the objective previously engaged into the light path is selected again.
- ★ **Never attempt to rotate the revolving nosepiece by hand. Rotating by hand may damage the gears, or cause other malfunctions.**
- ◎ The pin ③ for blind operation is placed below the selector button [1].

Objective Interchange

- ◎ Press the RECALL button on switch between two desired objectives.
 1. Select the first objective by pressing the corresponding objective selector button.
 2. When the objective selector button corresponding to the second objective is pressed, the setting is completed. When the RECALL button ② is pressed, the two objectives will be engaged alternately.
- ◎ The "recall-position" is retained in memory even if the main switch of the power supply unit (U-PS) is set to ○(OFF).

5-2 Stage

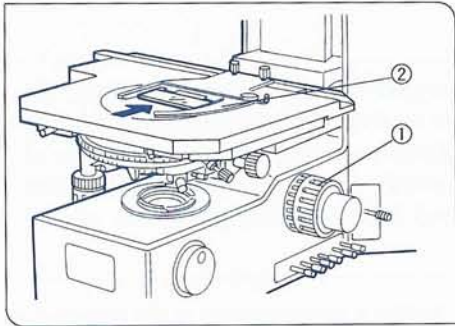

Fig. 29

1 Specimen Placement (Fig. 29)

1. Turn the coarse adjustment knob ① to lower the stage.
2. Open the spring-loaded curved finger ② on the specimen holder and place the specimen slide on to the stage from the front.
3. After placing the slide as far as it will go, gently release the curved finger.
 - ★ The maximum applicable slide dimensions are 26 X 76 mm (1" X 3") (max. 2 slide glasses), with a thickness of 0.9–1.4 mm and cover glass thickness of 0.17 mm.
 - ★ When observing very large specimens, remove the specimen holder and use the stage as a plain stage.

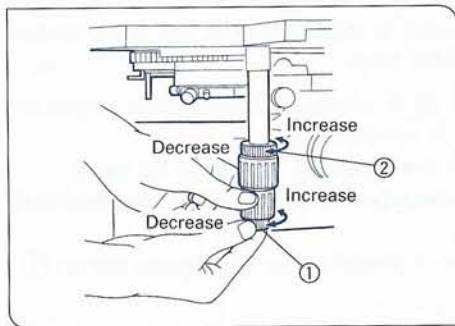

Fig. 30

2 Adjusting the Tension of X-axis and Y-axis knob (Fig. 30)

- ⊙ The tension of the X-axis and Y-axis knobs can be individually adjusted. Turning the X adjustment knob ① or the Y adjustment knob ② counter-clockwise increases tension, and turning them clockwise reduces tension. When adjusting the tension, hold the X-axis and Y-axis knobs to keep them from turning along with the tension adjustment knobs.
- ⊙ If the tension is adjusted too tight, a creaking sound may be heard during stage travel, and the stage may return back to its original position when stopped.

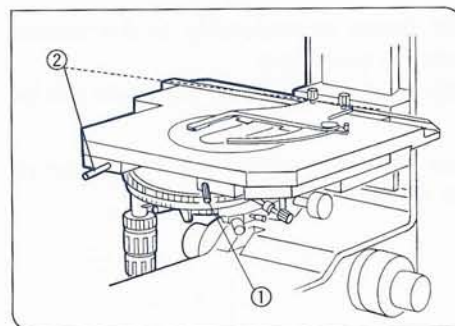

Fig. 31

3 Rotating the Stage (Fig. 31)

1. Slightly loosen the stage clamping screw ①.
 2. The stage is rotated by stable rotation screws ② (2 locations at front and back), but it can also be rotated to right and left directions by holding the stage fixing screw.
 3. If the stage fixing screw is tightened, the stage is fixed at optional position.
 - ★ In this case, the observation object may move and the image may be out of focus.
- ⊙ The angle of rotation varies, depending on the position of the stage knobs.

	Angle of rotation	
	Clockwise	Counterclockwise
Right hand knobs	220°– 235°	0°– 20°
Left hand knobs	0°–20°	220°– 235°

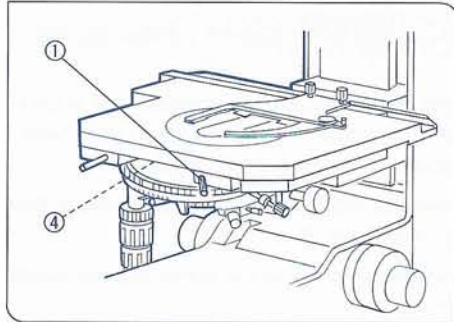

Fig. 32

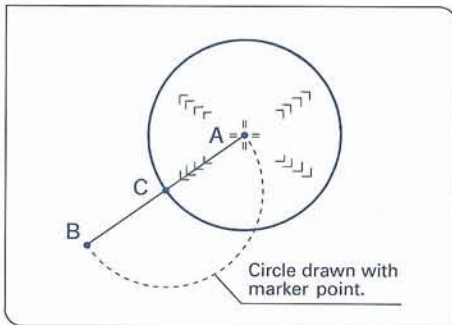

Fig. 33

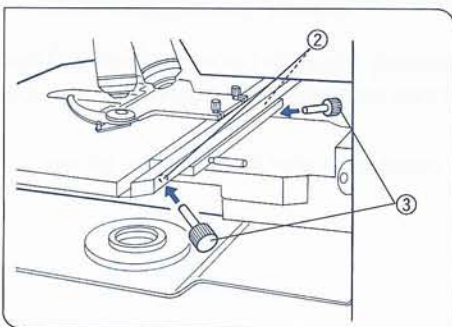

Fig. 34

4 Stage Rotation Centering

(Figs. 32, 33, 34)

◎ The higher power the objective, the more accurate the centering. For practical purposes, however, the 10X objective will be sufficient.

1. Focus on the specimen and look for an easily recognizable detail in the field. Move this detail in the center of the eyepiece crosslines with the coaxial stage movement knobs.
2. Loosen the stage clamping screw, and rotate the stage approximately 180°. (Fig. 32)

3. When the stage is rotated, the detail moves in a circle from A to B. Insert the provided centering knobs ③ into the stage centering knobs ② and coincide the detail with the imaginary center C of the A-B circle. (Fig. 33, 34)

- ★ When it cannot move centering around the marker point, loosen the locking screw ④.
- ★ There is a case where the image is out-focused while stage centering screw is operated.

4. Turn the coaxial movement knobs to move the specimen so that the detail coincide with the cross line center again C → A. (Fig. 34)
5. Repeat steps 2 and 4 several times until the center of the stage rotation is in the center of the cross lines, i.e., when rotating the stage, the specimen detail remains in the center of the cross lines.
6. Fix the locking screw lightly.

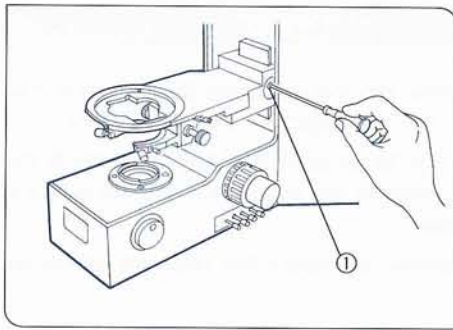

Fig. 35

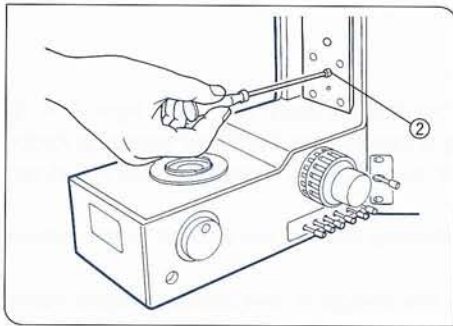

Fig. 36

5 Height Adjustment

(Figs. 35, 36)

⊙ By lowering the position of the substage, the microscope will accommodate specimens with maximum heights of 40 mm. This is useful when observing metallurgical specimens and other thick objects.

1. Using Allen screwdriver, loosen the substage bracket clamping screw ① and remove the substage. (Ref. to p. 3)
2. Using the Allen screwdriver, loosen and remove the upper stopper screw ②.
3. Reattach substage bracket and stage.
4. Then attach the stopper screw ② to the lower screw hole. (Fig. 36)
5. Replace the stage holder and stage to the original position.

5-3 Observation Tube

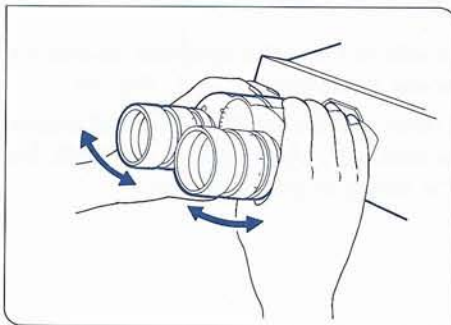

Fig. 37

1 Interpupillary Distance Adjustment

(Fig. 37)

While looking through the eyepieces, adjust for binocular vision until the left and right fields of view coincide completely. The index dot • indicates the interpupillary distance.

⊙ Dot down your interpupillary distance so that it can quickly be set.

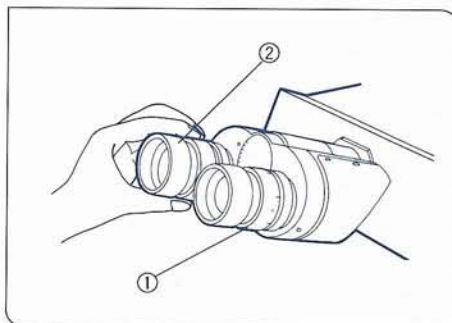

Fig. 38

2 Diopter Adjustment

(Figs. 38, 39)

1. Looking through the photo-format eyepiece ① with your right eye, turn the knurled top of the eyepiece ② until two distinct sets of reticles and a clearly defined double crossline can be seen in the field of view. (Fig. 38)

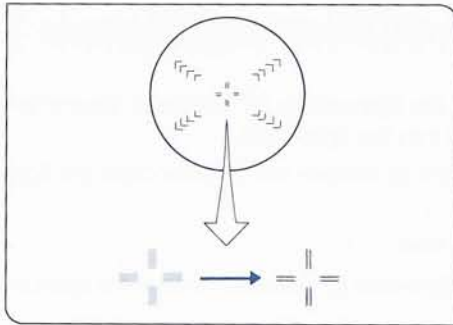

Fig. 39

2. Looking through the right eyepiece, rotate the fine adjustment knob to bring the specimen and reticles into simultaneous focus.
3. Looking through the left eyepiece with your left eye, turn the knurled top of the eyepiece ② to focus on the specimen.

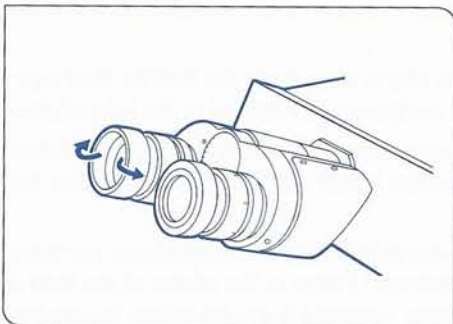

Fig. 40

3 Using the Eye Shades

(Fig. 40)

When Not Wearing Eyeglasses

With the eye shades in their normal extended position, observe with your eyes close to the eye shades.

When Wearing Eyeglasses

Fold the eye shades down with both hands.

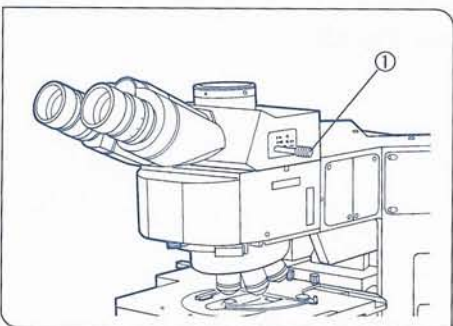

Fig. 41

4 Light Path Selection

(Fig. 41)

Slide the light path selector knob ① to select the desired light path.

- Ⓞ The selector knob is ordinarily at the middle position. With dark specimens, push the knob in. If additional light is needed for television or photomicrography, pull the knob out.

Light path selector knob	Symbol	Intensity ratio	Application
Pushed in		100% for binocular eyepieces	Observation of dark specimens
Middle position		20% for binocular eyepieces, 80% for TV/photography	Observation of bright specimens, photography, TV observation, AF
Pulled out		100% for TV/photography	Photography, TV observation, AF

- Ⓞ When using the U-SWETR, two options are available; i.e. 100% for binocular eyepieces or 100% for TV/photography.

5-4 Condenser

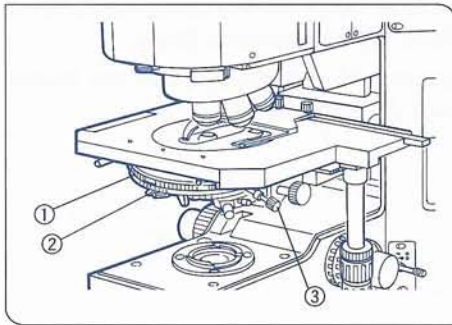

Fig. 42

5

USING THE CONTROLS

1 Condenser Centering

(Figs. 42, 43, 44, 45)

1. Rotate the turret ①, to select the light path for BF brightfield observation (no optical element engaged into the light path).
2. Pull the polarizer knob outward to remove the polarizer from the light path.
3. Swing in the condenser top lens.
4. Rotate the aperture iris diaphragm lever ② clockwise to open the aperture iris diaphragm.
5. Rotate the field iris diaphragm ring ③ to open the field iris diaphragm. (Fig. 42)
6. Place the specimen on the stage. Engage the 10X objective and focus on the specimen.
7. Rotate the field iris diaphragm ring to stop down the field iris diaphragm so that the diaphragm image becomes inscribed in the field of view.
8. While observing through the eyepieces, raise the condenser to its upper limit. Bring the field iris diaphragm image and the specimen image into simultaneous focus.
9. Gradually open the field iris diaphragm. Turn the condenser centering screw ③ to move the iris diaphragm image to the center of the field of view. (The condenser is properly centered if the iris image is centered and inscribed in the field of view.) (Fig. 42)
10. During actual use, open the field diaphragm slightly until its image circumscribes the field of view. (Fig. 43)

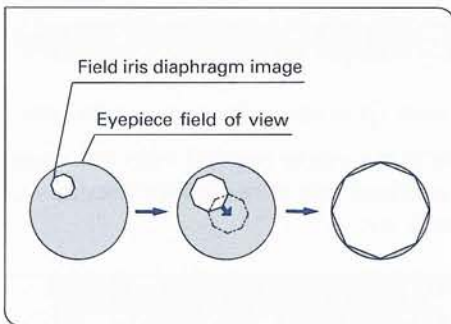

Fig. 43

Field Iris Diaphragm

The field iris diaphragm restricts the diameter of the beam of light entering the objective and thus excludes extraneous light, improving image contrast. The diameter of the field iris should be adjusted for each objective power to the extent that it just circumscribes the field of view. (See "Compatibility of Objectives and Condensers" on next page.)

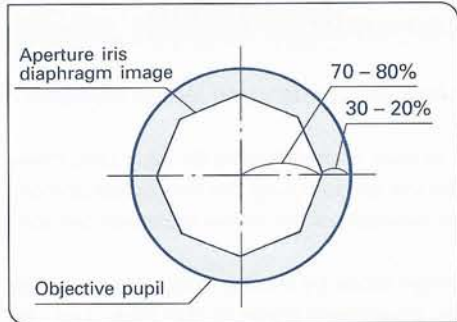

Fig. 44

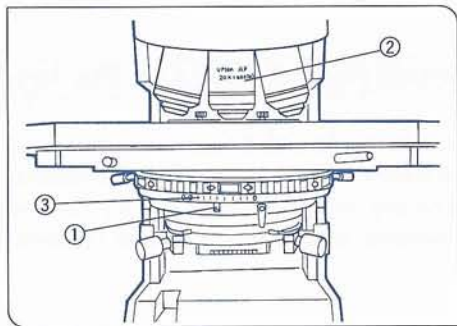

Fig. 45

Aperture Iris Diaphragm

- The aperture iris diaphragm determines the numerical aperture of the illumination system. Matching the numerical aperture of the illumination system with that of the objective provides better image resolution and contrast, and also increases the depth of focus.
- Since the contrast of microscope specimens is ordinarily low, setting the condenser aperture iris diaphragm to 70 - 80% of the N.A. of the objective in use is usually recommended. When necessary, adjust the ratio by removing the eyepiece and looking into the eyepiece sleeve while adjusting the aperture iris diaphragm lever ① until the image shown in Fig. 44 is seen. (Fig. 45)

◎ **Using the Numerical Aperture Scale**

Set the condenser numerical aperture scale ③ to about 80% of the NA value ② indicated on the objective.

(Example) With the UPlan Apo 20X (NA 0.70), the calculated setting will be $0.70 \times 0.8 = 0.56$; i.e. the scale should be set to 0.55.

- ★ When using an oil immersion type top lens, use the upper turret (TLO) aperture iris diaphragm scale.

Compatibility of Objectives and Condensers

Objective magnification	Condenser			
	Universal condenser U-UCDB	Achromat Aplanat U-AAC	Swing-out Achromat U-SC	Ultra-low magnification U-ULC-2
1.25X	Usable by moving top lens out of the light path.*1	/	Usable by moving top lens out of the light path.*1	Usable
2X				
4X				
10-60X	Top lens in light path.	Usable	Top lens in light path.	
100X	NA not fully matched to objective NA.*3		NA not fully matched to objective NA.*2	

*1 When using the universal condenser U-UCDB or U-SC swing-out achromat condenser together with the 2X or 4X objective, fully open the condenser aperture and use the field iris diaphragm in the base as aperture diaphragm.

*2 The slightly lower NA results in a somewhat darker field of view with a 100X objective, but the combination is usable.

◎ To obtain better illumination, use of the U-ULC-2 is recommended in photomicrography when using the 2X or 4X objective.

*3 The problem of lower NA can be eliminated by using the immersion top-lens (U-TLO) for the universal condenser.

5-5 Focusing Adjustment Knobs

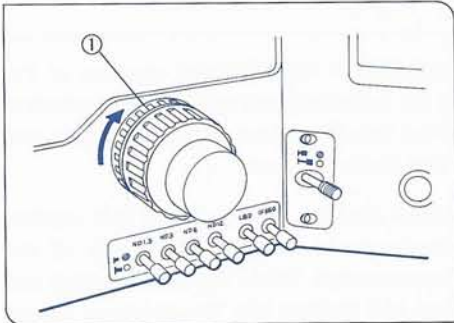

Fig. 46

1 Adjusting Coarse Adjustment Knob Tension (Fig. 46)

- ⊙ Adjust the coarse adjustment knob tension using the tension adjustment ring ①.

The coarse adjustment knob tension is preadjusted for easy use. However, if desired, one can change the tension using the tension adjustment ring ①. Turning the ring in the direction of the arrow increases tension, and vice versa.

The tension is too low if the stage drops by itself or focus is quickly lost after adjustment with the fine adjustment knob. In this case, turn the ring in the direction of the arrow to increase friction.

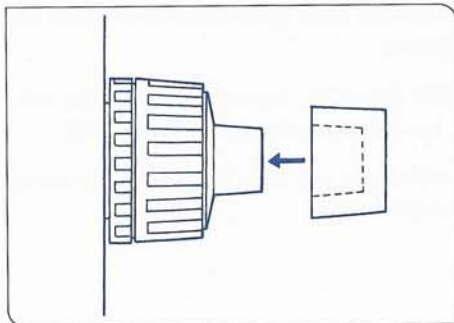

Fig. 47

2 Using the Fine Adjustment Knob Rubber Cap (Fig. 47)

- ⊙ Ordinarily, the fine adjustment knob is used with the rubber cap attached. However, if space between the knob and the stage controls is insufficient, the cap may be removed. The cap makes it easier to turn the fine adjustment knob in small increments to obtain more precise focusing.

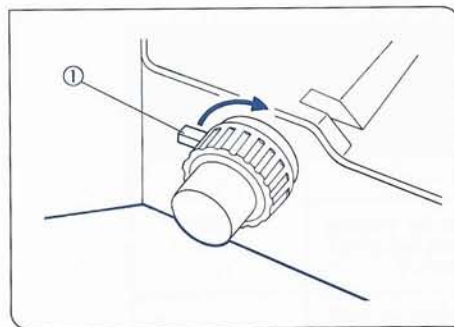

Fig. 48

3 Pre-focusing Lever (Fig. 48)

- ⊙ The pre-focusing lever ensures that the objective does not come in contact with the specimen and simplifies focusing. After focusing on the specimen with the coarse adjustment knob, turn this lever ① in the direction of the arrow to set an upper limit on coarse adjustment movement. After changing specimens, refocusing is easily accomplished by rotating the coarse adjustment knob to reach the pre-focused position, then making fine adjustments with the fine adjustment knob.

- ⊙ Stage movement with the fine adjustment knob is not affected by this pre-focusing lever.

5-6 Immersion Objectives

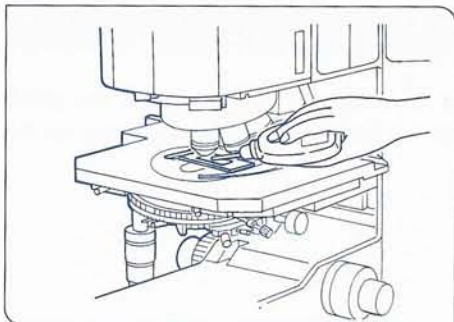

Fig. 49

1 Use of Immersion Objectives

(Fig. 49)

1. Focus on the specimen with the 10X objective.
2. Place a drop of immersion oil (provided) onto the specimen at the area to be observed.
3. Turn the revolving nosepiece to engage the immersion objective, then focus using the fine adjustment knob.
 - ★ Since bubbles in the oil will affect the image quality make sure that the oil is free of bubbles.
 - a. To check for bubbles, remove the eyepiece and fully open the field and aperture iris diaphragms, then look at the exit pupil of the objective inside the observation tube. (The pupil should appear round and bright.)
 - b. To remove bubbles, repeatedly defocus and refocus the oil immersion objective a few times.
- © If the condenser marking shows a numerical aperture (NA) of 1.0 or more, the number applies only when oil is present between the slide glass and the top surface of the condenser. When oil is not present, the NA is about 0.9.
4. After use, remove oil from the objective front lens by wiping with gauze slightly moistened with an ether (7 parts)/alcohol (3 parts) mixture or with xylene.
 - ★ Using too much xylene can dissolve the lens adhesive.

5

USING THE CONTROLS

5-7 Photomicrography

Photomicrography can be performed using the PM-10, the PM-20, or the PM-30 photomicrographic systems. Procedures for operating the photomicrographic units are described in their respective instruction manuals. Procedures specific to this microscope are described below.

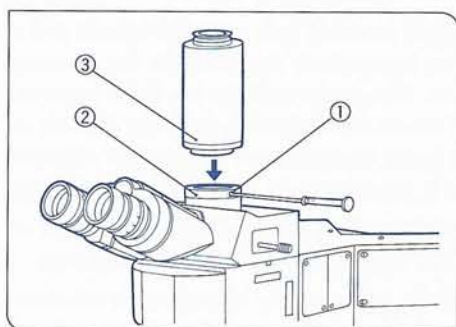

Fig. 50

1 Attaching the Straight Photo Tube (U-SPT)

(Fig. 50)

1. Using the Allen screwdriver, loosen the clamping screw ① on the trinocular tube photo port.
2. Align the vertical index line ② with the index dot ③ on the straight photo tube, then mount the straight photo tube on the trinocular tube photo port.
3. Tighten the clamping screw ①.

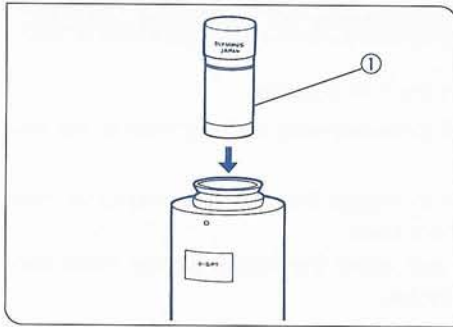

Fig. 51

2 Photo Eyepiece

(Fig. 51)

Use the PE photo eyepiece for photomicrography. Insert the photo eyepiece of your choice into the straight photo tube mounted on the trinocular observation tube.

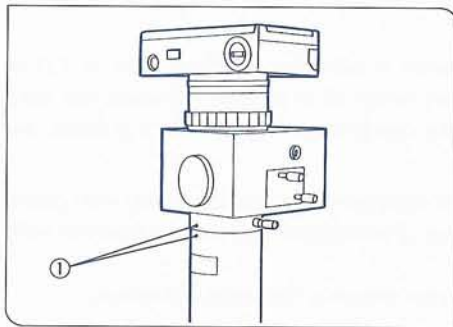

Fig. 52

3 Mounting the Camera Unit

(Fig. 52)

Place the camera unit directly over the circular dovetail of the straight photo tube. Make sure the index dots ① on the straight photo tube and the camera unit are aligned, then clamp the unit.

4 Selecting the Observation Tube Light Path

See p. 21 of the "Observation Tube" section.

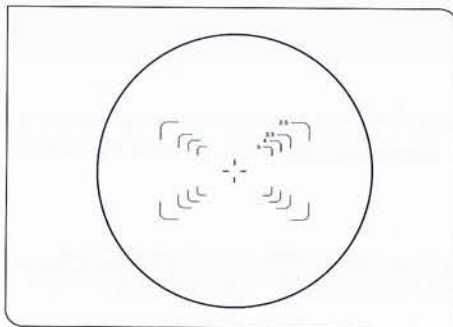

Fig. 53

5 Focus Adjustment

(Fig. 53)

1. Camera focusing is done using the binocular section of the trinocular observation tube.
 - ★ Whenever you remove the focusing telescope from the camera unit, be sure to install the dust cap.
2. Insert a finder eyepiece into the right eyepiece sleeve.
3. The finder eyepiece has a built-in focusing lens with four masks and a double crossline, and the focus is practically the same for the focusing lens and the camera film plane. The masks indicate the areas covered, and the numerals next to the masks correspond to the magnification of the photo eyepiece. Different finder eyepieces are available for different cameras. Select the type that is appropriate for the camera being used.
4. Because of the great depth of focus of 1.25X to 4X objectives, use of the focusing magnifier (U-FT) is recommended for accurate focusing.
 - © When using low power objectives, focusing may be accomplished easier using the focusing telescope on the camera unit rather than the finder eyepiece.

6 OBSERVATION METHODS

6-1 Phase Contrast Observation

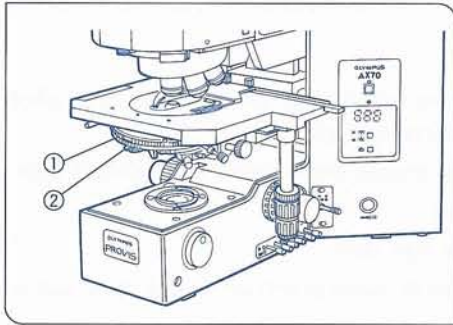

Fig. 54

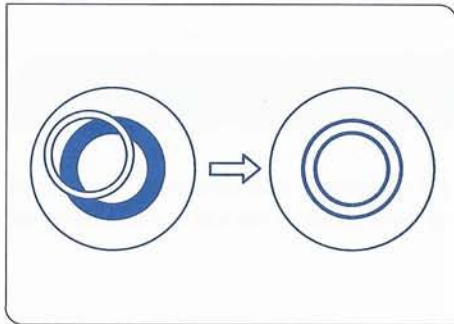

Fig. 55

1. Rotate the condenser turret to engage the phase contrast ring attachment (U-Ph1/Ph2/Ph3) that matches the objective to be used. (Refer to "OPTICAL ELEMENTS AND COMPATIBLE OBJECTIVES" on page 24 in the BX-UCDB instruction manual.)
 2. Pull the polarizer displacement knob outward to remove the polarizer from the light path.
 3. Mount the phase contrast objective to be used on the revolving nosepiece. Rotate the nosepiece to engage the objective.
 4. Using the aperture iris diaphragm lever ②, open the aperture iris diaphragm.
 - ★ If the aperture iris diaphragm is stopped down, diffraction may occur at the center.
 5. Place the specimen on the stage and then operate the coarse and fine focus adjustment knobs to bring the specimen into focus.
 6. Remove the eyepiece from the eyepiece sleeve, and replace with the centering telescope (U-CT30).
 7. Rotate the knurled ring on the centering telescope and bring the bright annulus (condenser ring slit) and the dark annulus (objective phase plate) into focus.
 8. Use the condenser annulus centering knobs to center the phase contrast attachment in such a way that the bright annulus concentrically overlaps the phase annulus within the field of view. (Fig. 55)
 - ★ Although a multiple number of annular images may appear, select the brightest annulus to center over the phase annulus.
 9. Repeat steps 7 and 8 for each objective.
 10. Remove the centering telescope (U-CT30) and replace it with the eyepiece.
 11. Open the field iris diaphragm until the diaphragm image circumscribes the field of view.
- © Insert the green interference filter 45-IF550 if increased contrast is required.

6 OBSERVATION METHODS

6-1 Phase Contrast Observation

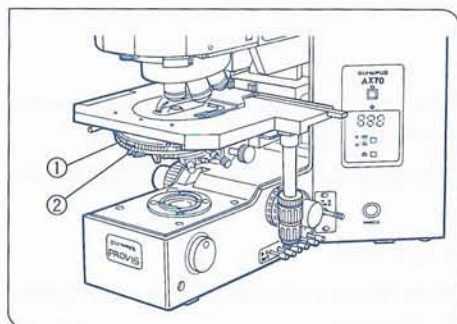

Fig. 54

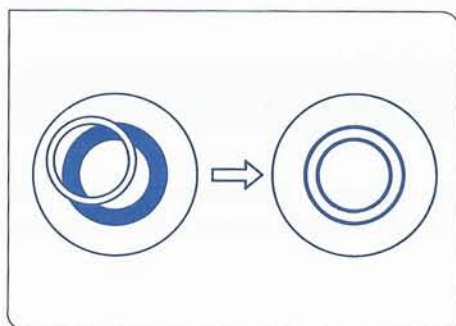

Fig. 55

1. Rotate the condenser turret to engage the phase contrast ring attachment (U-Ph1/Ph2/Ph3) that matches the objective to be used. (Refer to "OPTICAL ELEMENTS AND COMPATIBLE OBJECTIVES" on page 24 in the BX-UCDB instruction manual.)
2. Pull the polarizer displacement knob outward to remove the polarizer from the light path.
3. Mount the phase contrast objective to be used on the revolving nosepiece. Rotate the nosepiece to engage the objective.
4. Using the aperture iris diaphragm lever ②, open the aperture iris diaphragm.
 - ★ If the aperture iris diaphragm is stopped down, diffraction may occur at the center.
5. Place the specimen on the stage and then operate the coarse and fine focus adjustment knobs to bring the specimen into focus.
6. Remove the eyepiece from the eyepiece sleeve, and replace with the centering telescope (U-CT30).
7. Rotate the knurled ring on the centering telescope and bring the bright annulus (condenser ring slit) and the dark annulus (objective phase plate) into focus.
8. Use the condenser annulus centering knobs to center the phase contrast attachment in such a way that the bright annulus concentrically overlaps the phase annulus within the field of view. (Fig. 55)
 - ★ Although a multiple number of annular images may appear, select the brightest annulus to center over the phase annulus.
9. Repeat steps 7 and 8 for each objective.
10. Remove the centering telescope (U-CT30) and replace it with the eyepiece.
11. Open the field iris diaphragm until the diaphragm image circumscribes the field of view.
 - ◎ Insert the green interference filter 45-IF550 if increased contrast is required.

6-2 Simple Polarized Light Observation

© To perform simple polarized light observation, an analyzer (U-ANT or U-AN) is needed. Refer to the instruction manual for the transmitted light analyzer (U-ANT).

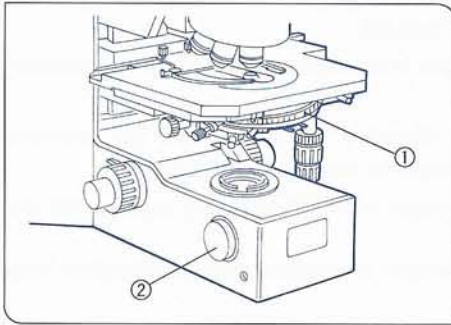
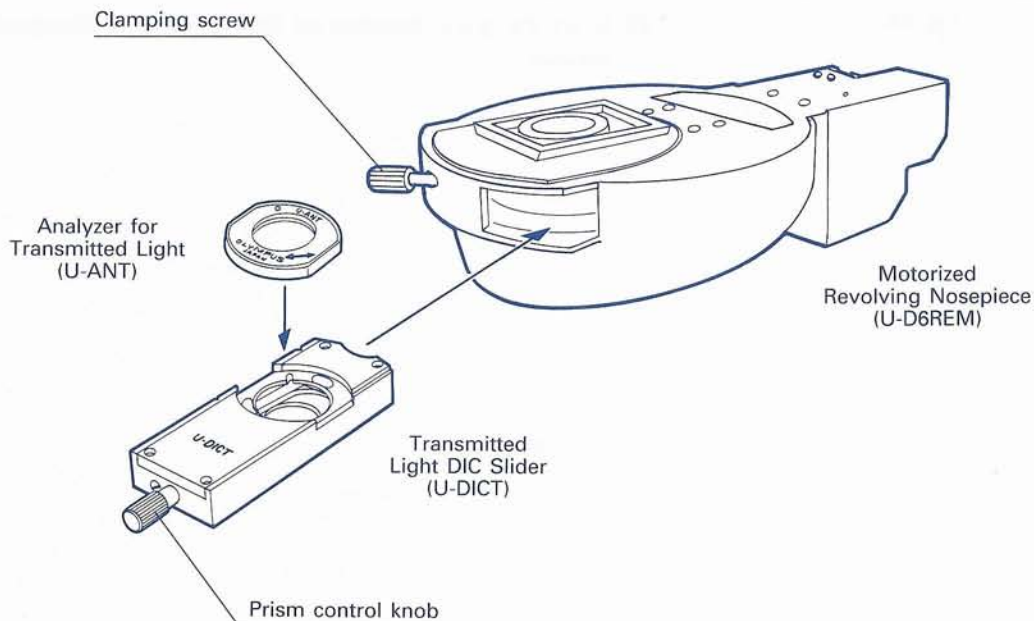

Fig. 56

1. Turn the turret ① and select the light path for BF brightfield observation (no optical element engaged into the light path).
 2. Push in the polarizer knob to engage the polarizer into the light path.
 3. Engage the required objective.
 4. Engage the analyzer into the light path.
 5. Turn the polarizer rotation knob to obtain extinction. At this point, tighten the clamping knob.
- © The "crossed Nicol" position (total extinction) should be near the 0° position index.
6. Place the specimen on the stage then operate the coarse and fine focus adjustment knobs to bring the specimen into focus.
 7. Adjust the field iris diaphragm ring ② until the diaphragm image circumscribes the field of view.
 8. Stopping down the aperture iris diaphragm may increase the contrast somewhat.

6-3 Nomarski Differential Interference Contrast Observation

To perform Nomarski differential interference contrast observation (DIC), the transmitted light differential interference contrast slider (U-DICT) and analyzer (U-ANT or U-AN) are required. Refer to the instruction manual of the transmitted light DIC slider.



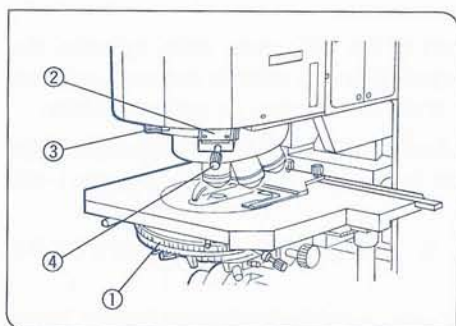

Fig. 57

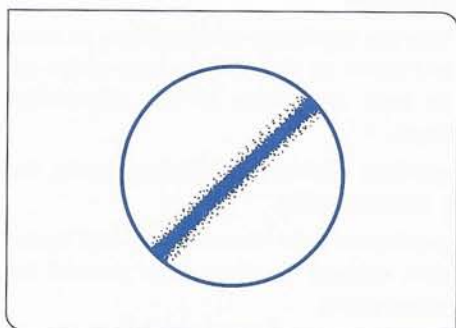

Fig. 58

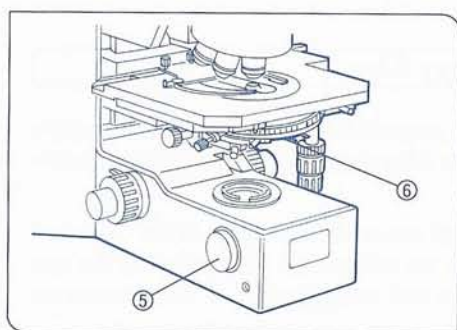

Fig. 59

1. Rotate the turret ① to combine the turret position with an interference prism matched with the objective to be used. (Fig. 57)
2. Adjust the polarizer as outlined in the following steps.
 - a. Engage the transmitted light DIC slider (U-DICT) into the light path ② and tighten the clamping screw ③.
 - b. Turn the turret ① and select the light path for BF brightfield observation (no optical element engaged into the light path).
 - c. Rotate the prism control knob ④ of the DIC slider clockwise as far as it will go.
 - d. Push the polarizer knob all the way in to engage the polarizer into the light path.
 - e. Engage the desired objective into the light path, bring the specimen into approximate focus and then replace the eyepiece with the centering telescope (U-CT30).
 - f. Rotate the knurled ring on the centering telescope (U-CT30) and bring the objective pupil into focus.
 - g. As the polarizer rotation knob is turned while looking at the objective pupil through the centering telescope, a black fringe will appear at a certain position. The polarizer should be rotated to the position where this black fringe is darkest. (Fig. 58)
- ⊙ The "crossed Nicol" position (total extinction) should be near the 0° position index.
 - ★ If two black fringes appear, rotate the polarizer approximately 90° so that only one black fringe is visible.
- h. Once the position of the polarizer is determined, tighten the polarizer clamping knob.
3. Rotate the turret and engage the DIC prism that matches the objective to be used.
4. Engage the objective to be used.
5. Place the specimen on the stage then use the coarse and fine focus adjustment knobs to bring the specimen into focus.
6. Adjust the field iris diaphragm ring ⑤ until the diaphragm image circumscribes the field of view.
7. Stopping down the aperture iris diaphragm, using the lever ⑥, may increase the contrast somewhat. (Fig. 59)

8. Rotate the prism control knob of the DIC prism slider to select the interference color of the background, and to achieve maximum contrast depending on the specimen under observation, as outlined below.
 - a. Rotating the prism control knob of the slider will continuously change the interference color of the background from gray to magenta (–100 to 600 nm).
 - If the background color is black, (0-order fringe), darkfield-like observation is possible.
 - If the background color is gray, a three-dimensional looking image with maximum contrast can be obtained.
 - If the background color is magenta, even a minor optical retardation can be observed as a color change.
 - ★ Care should be taken to keep the specimen surface clean, as even a small amount of contamination on the surface may show up due to the exceptionally high sensitivity of the differential interference contrast method.
 - b. As differential interference contrast exhibits directional sensitivity, the use of a rotatable stage is recommended.
 - ★ To perform simultaneous reflected light fluorescence and transmitted light DIC observation, refer to the instruction manual for the AX70 reflected light attachment.
 - c. Since plastic material depolarizes light, the differential interference effect will not be fully achievable in case of such materials.

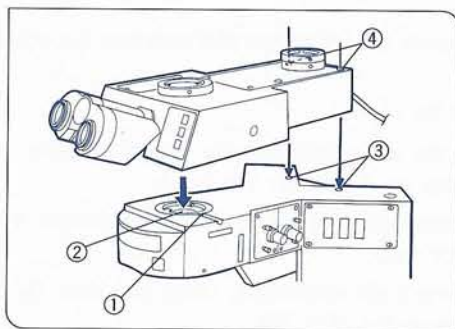

Fig. 60

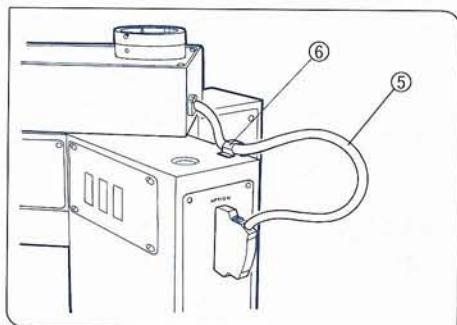

Fig. 61

Installation of Multi-port Tube

1. Using the provided Allen screwdriver, loosen the observation tube clamping screw ① on the microscope frame (intermediate attachment).
2. Insert the circular dovetail mount at the bottom of the multi-port head into the opening on the microscope frame, aligning the two rear protrusions with the two indentions ③ on the microscope frame.
3. Using the Allen screwdriver, tightening the clamping screw ①.
4. To clamp the attachment, insert the Allen screwdriver into the two holes ④ on top of the multi-port head and tighten the screws inside. (Fig. 60)
5. Attach the cable stopper ⑥ as shown in the diagram, and insert the communication cable into it. Then, connect the communication cable ⑤ to the OPTION connector on the microscope frame. (Fig. 61)

7 SPECIFICATIONS

Item	Specification			
(1) Optical system	UIS (Universal Infinity System) optical system			
(2) Transmitted light illumination	Built-in transmitted Koehler illumination (Super widefield applicable: Field number 26.5) Observation tube magnification: 1X, (Super widefield applicable: Field number 26.5) Phase contrast observation, simple polarized light observation, Nomarski differential interference contrast observation			
(3) Electrical system	12V 100W Halogen bulb (pre-centered) (Average life time: approximately 2000 hrs. when used as directed) Light intensity voltage range 1.0 - 12.0V Transmitted light/reflected light selector switch			
(4) Focusing	Stage movement by roller guide (Rack & Pinion) Stroke per rotation: 0.1 mm (fine), 15 mm (coarse) Full range stroke: 25 mm Upper limit stopper Torque adjustment on coarse focus knob			
(5) Revolving nosepiece	Type	U-D6REM Motorized revolving nosepiece		
	Attachment	DIC slider for transmitted light (U-DICT)		
(6) Observation tube	Type	U-SWTR2 Super widefield trinocular tube	U-SWETR Super widefield erect image trinocular tube	
	Field No.	26.5		
	Tube inclination	24°		
	Interpupillary dist. adjustment	50 – 76 mm		
	Light path selector	3 steps: ① Bi 100% ② Bi 20%, Photo 80% ③ Photo, TV 100%		2 steps: ① Bi 100% ② Photo, TV 100%
(7) Stage	Type	AX-SVL Low positioned coaxial knobs on the left side stage	AX-SVR Low positioned coaxial knobs on the right side stage	
	Size	198 (H) X 265 (W) mm		
	Movement	Adjustable vertical and horizontal knob tension Movement range: 52 mm Y-direction, 76 mm X-direction		
	Specimen holder	Double slide holder		
(8) Condenser	Type	U-UCDB Universal condenser	U-ULC-2 For low power objectives	U-AAC Achromat aplanat condenser
	Top lens	Top lens swing-out condenser	Immersion top lens swing-out	—
	N.A.	0.9 (top lens in) 0.2 (top lens out)	1.4 (top lens in) 0.2 (top lens out)	0.16
	Aperture iris diaphragm	With numerical aperture scale		
	Objective range	2X – 100X	2X to 4X (slight vignetting with 1.25X objective)	10X – 100X

Item	Specification																					
(10) Power supply unit	Rating	Power consumption: 100 – 240V 50/ 60 Hz 4.8A Applicable fuse: T6 3A(H) 250V (Time Lag) High-breaking capacity LITTELFUSE 21506.3																				
	Rating power	<table border="1" data-bbox="754 491 1307 873"> <thead> <tr> <th data-bbox="754 491 1031 534">Rated output voltage</th> <th data-bbox="1031 491 1307 534">Rated output current</th> </tr> </thead> <tbody> <tr> <td data-bbox="754 534 1031 577">DC 5.3V(1)</td> <td data-bbox="1031 534 1307 577">3.8A</td> </tr> <tr> <td data-bbox="754 577 1031 620">DC 5V (2)</td> <td data-bbox="1031 577 1307 620">0</td> </tr> <tr> <td data-bbox="754 620 1031 664">DC 8V</td> <td data-bbox="1031 620 1307 664">0.1A</td> </tr> <tr> <td data-bbox="754 664 1031 707">DC 12V (1)</td> <td data-bbox="1031 664 1307 707">1.3A</td> </tr> <tr> <td data-bbox="754 707 1031 750">DC 12V (2)</td> <td data-bbox="1031 707 1307 750">10 mA</td> </tr> <tr> <td data-bbox="754 750 1031 793">DC 15.2V</td> <td data-bbox="1031 750 1307 793">0.3A</td> </tr> <tr> <td data-bbox="754 793 1031 836">DC -15V</td> <td data-bbox="1031 793 1307 836">0.1A</td> </tr> <tr> <td data-bbox="754 836 1031 879">DC 24.2V</td> <td data-bbox="1031 836 1307 879">1.3A</td> </tr> <tr> <td data-bbox="754 879 1031 933">DC 1-12.6V</td> <td data-bbox="1031 879 1307 933">9.4A (max. at 12.6V)</td> </tr> </tbody> </table>	Rated output voltage	Rated output current	DC 5.3V(1)	3.8A	DC 5V (2)	0	DC 8V	0.1A	DC 12V (1)	1.3A	DC 12V (2)	10 mA	DC 15.2V	0.3A	DC -15V	0.1A	DC 24.2V	1.3A	DC 1-12.6V	9.4A (max. at 12.6V)
Rated output voltage	Rated output current																					
DC 5.3V(1)	3.8A																					
DC 5V (2)	0																					
DC 8V	0.1A																					
DC 12V (1)	1.3A																					
DC 12V (2)	10 mA																					
DC 15.2V	0.3A																					
DC -15V	0.1A																					
DC 24.2V	1.3A																					
DC 1-12.6V	9.4A (max. at 12.6V)																					
	Input ratings	<table border="1" data-bbox="754 1009 1307 1390"> <thead> <tr> <th data-bbox="754 1009 1031 1052">Rated input voltage</th> <th data-bbox="1031 1009 1307 1052">Rated input current</th> </tr> </thead> <tbody> <tr> <td data-bbox="754 1052 1031 1095">DC 5.3V(1)</td> <td data-bbox="1031 1052 1307 1095">3.8A</td> </tr> <tr> <td data-bbox="754 1095 1031 1138">DC 5V (2)</td> <td data-bbox="1031 1095 1307 1138">0</td> </tr> <tr> <td data-bbox="754 1138 1031 1181">DC 8V</td> <td data-bbox="1031 1138 1307 1181">0.1A</td> </tr> <tr> <td data-bbox="754 1181 1031 1224">DC 12V (1)</td> <td data-bbox="1031 1181 1307 1224">1.3A</td> </tr> <tr> <td data-bbox="754 1224 1031 1267">DC 12V (2)</td> <td data-bbox="1031 1224 1307 1267">10 mA</td> </tr> <tr> <td data-bbox="754 1267 1031 1310">DC 15.2V</td> <td data-bbox="1031 1267 1307 1310">0.3A</td> </tr> <tr> <td data-bbox="754 1310 1031 1353">DC -15V</td> <td data-bbox="1031 1310 1307 1353">0.1A</td> </tr> <tr> <td data-bbox="754 1353 1031 1397">DC 24.2V</td> <td data-bbox="1031 1353 1307 1397">1.3A</td> </tr> <tr> <td data-bbox="754 1397 1031 1450">DC 1-12.6V</td> <td data-bbox="1031 1397 1307 1450">9.4A (max. at 12.6V)</td> </tr> </tbody> </table>	Rated input voltage	Rated input current	DC 5.3V(1)	3.8A	DC 5V (2)	0	DC 8V	0.1A	DC 12V (1)	1.3A	DC 12V (2)	10 mA	DC 15.2V	0.3A	DC -15V	0.1A	DC 24.2V	1.3A	DC 1-12.6V	9.4A (max. at 12.6V)
Rated input voltage	Rated input current																					
DC 5.3V(1)	3.8A																					
DC 5V (2)	0																					
DC 8V	0.1A																					
DC 12V (1)	1.3A																					
DC 12V (2)	10 mA																					
DC 15.2V	0.3A																					
DC -15V	0.1A																					
DC 24.2V	1.3A																					
DC 1-12.6V	9.4A (max. at 12.6V)																					

8 OPTICAL CHARACTERISTICS

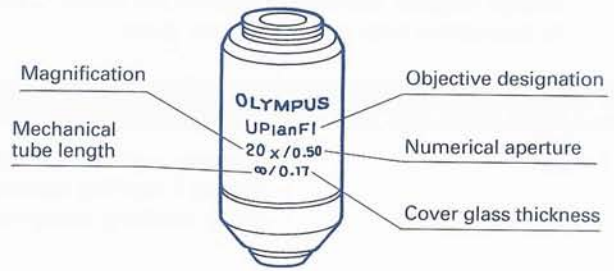

Optical character Objective designation	Magnification	N.A.	W.D. (mm)	Cover glass thickness	Resolution (μm)	Eyepiece			Remarks
						SWH10X (26.5)			
						Total mag.	Depth of focus (μm)	Field of view	
UPlan FI Universal (FN26.5)	4X	0.13	17.0	—	2.58	40X 100X 200X 400X 1000X 1000X	127 22.4 7.00 2.52 0.66 0.66	6.63 2.65 1.33 0.66 0.27 0.27	Iris
	10X	0.30	10.0	—	1.12				
	20X	0.50	1.6	0.17	0.67				
	40X	0.75	0.51	0.17	0.45				
	100XO	1.30	0.10	0.17	0.26				
	100XOI	0.60-1.30	0.10	0.17	0.26				
UPlan Apo Universal (FN26.5)	4X	0.16	13.0	—	2.1	40X 100X 200X 400X 400X 1000X	99.5 15.9 4.65 2.14 1.75 0.62	6.63 2.65 1.33 0.66 0.27 0.27	Collar Iris Iris
	10X	0.40	3.1	0.17	0.84				
	20X	0.70	0.65	0.17	0.48				
	40X	0.85	0.2	0.11-0.23	0.39				
	40XOI	0.5-1.00	0.12	—	0.34				
	100XOI	0.5-1.35	0.10	0.17	0.25				
Plan Apo Plan Achromat (FN26.5)	1.25X	0.04	5.1	—	8.38	12.5X 20X 400X 600X 1000X	872 398 1.86 0.85 0.59	21.2 13.3 0.66 0.44 0.27	Collar Iris
	2X	0.08	6.0	—	4.19				
	40X	0.95	0.14	0.11-0.23	0.35				
	60XO	1.40	0.10	0.17	0.24				
	100XO	1.40	0.10	0.17	0.24				
No Cover UMPLFL (FN26.5)	40X	0.75	0.63	0	0.45	400X	1.66	0.66	
No Cover MPLAPO (FN26.5)	100XO	1.40	0.10	0	0.24	1000X	0.59	0.27	
UApo/340 340 nm applicable (FN26.5)	20X	0.75	0.55	0.17	0.45	200X	4.29	1.33	Collar Iris
	40X	0.9	0.2	0.11-0.23	0.37	400X	1.99	0.66	
	40XOI	0.65-1.35	0.1	0.17	0.25	400X	1.21	0.66	

9 ERROR CODE CHART

If any anomalous condition is detected, a blinking error code number will be shown on the microscope frame's voltage indicator display and a buzzer will sound. Consult the following error code chart and take remedial action in accordance with the instructions given.

Code	Error condition	Remedy
01 • 02	Improper revolving nosepiece rotation. (Occurs if anything impedes the rotation of the revolving nosepiece.)	Remove the obstructing object(s). Turn the power ○(OFF) and then ◐(ON) again before attempting the operation again. If the same error occurs again, something is wrong with the equipment. In this event, contact your local Olympus representative for assistance.
23 • 24	Abnormal condition of the OPTION connector.	If the OPTION connector is in use, turn ○(OFF) the power and then check the connection of the connection cable. Try to operate the microscope again. If the same error occurs again, or if the error code appears when the connector is not in use, something is wrong with the equipment. In this event, contact your local Olympus representative for assistance.
30	Internal circuit malfunction.	Something is wrong with the equipment. Contact your local Olympus representative for assistance.

10 TROUBLESHOOTING GUIDE

Under certain conditions, performance of this unit may be adversely affected by factors other than defects. If problems occur, please review the following list and take remedial action as needed. If you cannot solve the problem after checking the entire list, please contact your local Olympus representative for assistance.

Problem	Cause	Remedy	Page
1. Optical System			
a. Bulb does not light.	Bulb burned out.	Replace bulb.	5
	Fuse burned out.	Replace fuse	8
b. Bulb operates, but field of view remains dark.	Field iris diaphragm is not opened wide enough. (Transmitted light)	Open the field iris diaphragm.	22
	When the brightfield light path is selected, the aperture and field iris diaphragms are stopped down. (Reflected light brightfield/darkfield)	Open both aperture and field iris diaphragms.	22
	Condenser is lowered too much.	Adjust the condenser height position.	22
	Trinocular tube light path selector knob is moved to (☒) position.	Move the lever to the (☑) or (☑) position.	21
c. Field of view is obscured, or field of view is not evenly illuminated.	Trinocular tube light path selector knob is not positioned correctly.	Fully engage the knob in the desired position.	21
	The revolving nosepiece is not correctly engaged.	Make sure that the revolving nosepiece clicks properly into place.	6
	The revolving nosepiece is not correctly mounted.	Slide the nosepiece along the dovetail as far as it will go, then tighten with screw.	6
	An objective that falls outside of the condenser's illumination range is used.	Use a condenser that matches the objective.	23
	The condenser is not properly centered.	Center the condenser.	22
	The field iris diaphragm is not properly centered.	Center the field iris diaphragm.	22
	The field iris diaphragm is stopped down too far.	Open the field iris diaphragm.	22
	The halogen bulb is not mounted correctly.	Push the pins of the halogen bulb fully into the proper pin holes.	5
	Analyzer and polarizer are not engaged correctly.	Engage the analyzer and polarizer correctly in the light path.	—
	d. Dirt or dust is visible in the field of view.	Dirt on the base light exit glass.	Clean thoroughly.
Dirt on the top surface of the condenser.		Dirt/dust on specimen.	—
Dirt/dust on eyepiece.		Dirt/dust on the front lens of the objective.	—
e. Phase contrast ring is visible in the field of view.	Condenser top lens is dirty.	Clean thoroughly.	—
f. The image shows diffraction.	Condenser is lowered too far.	Adjust the condenser height position.	23
	The aperture iris diaphragm is stopped down too far.	Open the aperture iris diaphragm.	23

Problem	Cause	Remedy	Page
g. Visibility is poor. • Image is not sharp. • Contrast is poor. • Details are indistinct.	Your are using a non-UIS series objective.	Use only UIS series objectives with this microscope.	5
	The revolving nosepiece is not positioned correctly.	Slide the nosepiece along the dovetail as far as it will go, then tighten with knob.	6
	The objective is not correctly engaged in the light path.	Make sure that the revolving nosepiece clicks into place correctly.	6
	The correction collar on the correction collar equipped objective is not properly adjusted.	While focusing, turn the correction collar to find the best position.	—
	Front lens of the objective is dirty.	Clean the objective.	—
	Immersion oil is not being used with an oil immersion objective.	Use immersion oil.	25
	The immersion oil contains bubbles.	Remove bubbles.	25
	Recommended immersion oil not used.	Used the provided immersion oil.	25
	Specimen is dirty.	Clean.	—
	Condenser is dirty.	Clean.	—
	Inappropriate object slide or cover glass thickness.	Replace with glass of recommended thickness.	18
h. Part of the image is blurred.	The revolving nosepiece is not properly mounted.	Slide the nosepiece along the dovetail as far as it will go, then tighten with screw.	6
	The objective is not correctly engaged in the light path.	Make sure that the revolving nosepiece clicks into place correctly.	6
	The specimen is not mounted correctly on the stage	Place the specimen correctly on top of the stage and secure it with the specimen holder.	18
i. The image appears to waver.	The revolving nosepiece is not properly mounted.	Slide the nosepiece along the dovetail as far as it will go, then tighten with screw.	6
	The objective is not correctly engaged in the light path.	Make sure that the revolving nosepiece clicks into place correctly.	6
	The condenser is not properly centered.	Center the condenser.	22
j. The field of view becomes only slightly brighter when the voltage is raised.	The condenser is not properly centered.	Center the condenser.	22
	Condenser is lowered too far.	Adjust the condenser position.	22
2. Electrical System			
a. The bulb intermittently lights and goes out.	The bulb is nearly burned out.	Replace the bulb.	5
	A connector plug is improperly connected.	Check all connections.	—
b. The bulb burns out almost immediately.	Wrong type of bulb used.	Use the correct bulb type.	5
c. Brightness does not change when you turn the light intensity dial.	The light preset button is set to ON.	Press the button to OFF.	14
d. The main switch LED does not light.	The connection cable is not connected.	Connect the connection cable correctly.	8

Problem	Cause	Remedy	Page
e. The voltage indication is seen blinking on the voltage display (when 2.0V or more).	The halogen lamp housing is not installed.	Install the halogen lamp housing.	5
	The bulb is burned out.	Replace the bulb.	5
	The lamp housing cord plug is disconnected.	Connect the lamp housing cord plug correctly.	6
	Set to reflected light (☞).	Switch to transmitted light setting (☜).	14
f. The objective selector button LEDs on the hand switch (U-HS) are blinking sequentially.	The objective is not at the click-stop.	Press an objective selector button.	17
g. Power to the power supply unit is interrupted.	Protective circuit is activated. Something near the power supply is obstructing ventilation and heat is accumulating.	Remove obstructing objects and wait for protective circuit to cool down.	—
3. Coarse/ Fine Adjustment			
a. The coarse adjustment knob is hard to turn.	The tension adjustment ring is tightened excessively.	Loosen the ring.	24
	You are trying to raise the stage with the coarse adjustment knob with the pre-focusing lever engaged.	Unlock the pre-focusing lever.	24
b. The stage drifts down by itself, or focus is lost during observation.	The tension adjustment ring is too loose.	Tighten the ring.	24
c. The image is not focused.	When adjusting the stage height, you forgot to reattach the upper stopper screw.	Reattach the upper stopper screw.	20
d. Coarse adjustment will not go all the way up.	The pre-focusing lever is keeping the stage down.	Unlock the pre-focusing lever.	24
e. Coarse adjustment will not go all the way down.	The condenser holder is too low.	Raise the condenser holder.	22
f. The objective makes contact with the specimen before focus is obtained.	The specimen is mounted upside-down.	Mount the specimen correctly.	18
4. Observation Tube			
a. Field of view of one eye does not match that of the other.	The interpupillary distance is incorrect.	Adjust the interpupillary distance.	20
	Incorrect diopter adjustment.	Adjust the diopter.	20
	Different eyepieces are used on the left and right.	Change one eyepiece to match the other so that both sides are the same.	7
	The optical axes are not parallel.	Upon looking into the eyepieces, try looking at the overall field before concentrating on the specimen range. You may also find it helpful to look up and into the distance for a moment before looking back into the microscope.	—
5. Stage			
a. The image shifts when you touch the stage.	The stage is not properly mounted.	Clamp the stage.	18
b. Specimen stops midway on the X axis traverse.	The specimen is not correctly positioned.	Place the specimen correctly.	18
c. The X axis and Y axis knobs are too tight, or too loose.	Is X or Y axis tension too high or too low?	Adjust the tension.	18



OLYMPUS

OLYMPUS OPTICAL CO., LTD.

43-2, Hatagaya 2-chome, Shibuya-ku, Tokyo, Japan

OLYMPUS OPTICAL CO., (EUROPA) GMBH.

(Premises/Goods delivery) Wendenstrasse 14-16, 20097 Hamburg, Germany
(Letters) Postfach 10 49 08, 20034 Hamburg, Germany

OLYMPUS AMERICA INC.

4 Nevada Drive, Lake Success, N.Y. 11042-1179, U.S.A.

OLYMPUS OPTICAL CO. (U.K.) LTD.

2-8 Honduras Street, London EC1Y0TX, United Kingdom

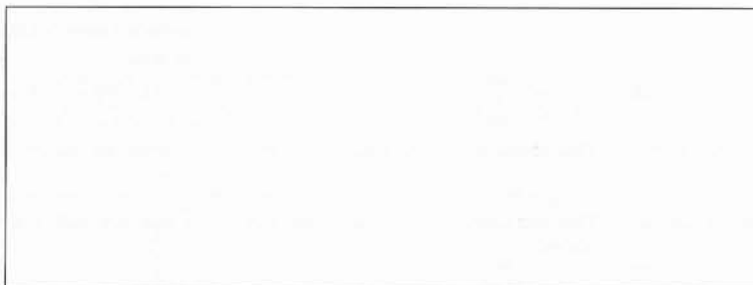

The design of the product is under constant review and whilst every effort is made to keep this manual up to date, the right is reserved to change specifications and equipment at any time without prior notice.