



Haas Automation, Inc.

---

# Mill Operator's Manual

96-8200  
Revision B  
October 2014  
English  
Original Instructions

---

To get translated versions of this Manual:  
1. Go to **[www.HaasCNC.com](http://www.HaasCNC.com)**  
2. See *Owner Resources* (bottom of page)  
3. Select *Manuals and Documentation*

Haas Automation Inc.  
2800 Sturgis Road  
Oxnard, CA 93030-8933  
U.S.A. | [HaasCNC.com](http://HaasCNC.com)



---

© 2014 Haas Automation, Inc.

All rights reserved. No part of this publication may be reproduced, stored in a retrieval system, or transmitted, in any form, or by any means, mechanical, electronic, photocopying, recording, or otherwise, without the written permission of Haas Automation, Inc. No patent liability is assumed with respect to the use of the information contained herein. Moreover, because Haas Automation strives constantly to improve its high-quality products, the information contained in this manual is subject to change without notice. We have taken every precaution in the preparation of this manual; nevertheless, Haas Automation assumes no responsibility for errors or omissions, and we assume no liability for damages resulting from the use of the information contained in this publication.



---

# LIMITED WARRANTY CERTIFICATE

Haas Automation, Inc.

Covering Haas Automation, Inc. CNC Equipment

Effective September 1, 2010

Haas Automation Inc. (“Haas” or “Manufacturer”) provides a limited warranty on all new mills, turning centers, and rotary machines (collectively, “CNC Machines”) and their components (except those listed below under Limits and Exclusions of Warranty) (“Components”) that are manufactured by Haas and sold by Haas or its authorized distributors as set forth in this Certificate. The warranty set forth in this Certificate is a limited warranty, it is the only warranty by Manufacturer, and is subject to the terms and conditions of this Certificate.

## Limited Warranty Coverage

Each CNC Machine and its Components (collectively, “Haas Products”) are warranted by Manufacturer against defects in material and workmanship. This warranty is provided only to an end-user of the CNC Machine (a “Customer”). The period of this limited warranty is one (1) year. The warranty period commences on the date the CNC Machine is installed at the Customer’s facility. Customer may purchase an extension of the warranty period from an authorized Haas distributor (a “Warranty Extension”), any time during the first year of ownership.

## Repair or Replacement Only

Manufacturer’s sole liability, and Customer’s exclusive remedy under this warranty, with respect to any and all Haas products, shall be limited to repairing or replacing, at the discretion of the Manufacturer, the defective Haas product.

## Disclaimer of Warranty

This warranty is Manufacturer’s sole and exclusive warranty, and is in lieu of all other warranties of whatever kind or nature, express or implied, written or oral, including, but not limited to, any implied warranty of merchantability, implied warranty of fitness for a particular purpose, or other warranty of quality or performance or noninfringement. All such other warranties of whatever kind are hereby disclaimed by Manufacturer and waived by Customer.

---

## **Limits and Exclusions of Warranty**

Components subject to wear during normal use and over time, including, but not limited to, paint, window finish and condition, light bulbs, seals, wipers, gaskets, chip removal system (e.g., augers, chip chutes), belts, filters, door rollers, tool changer fingers, etc., are excluded from this warranty. Manufacturer's specified maintenance procedures must be adhered to and recorded in order to maintain this warranty. This warranty is void if Manufacturer determines that (i) any Haas Product was subjected to mishandling, misuse, abuse, neglect, accident, improper installation, improper maintenance, improper storage, or improper operation or application, including the use of improper coolants or other fluids, (ii) any Haas Product was improperly repaired or serviced by Customer, an unauthorized service technician, or other unauthorized person, (iii) Customer or any person makes or attempts to make any modification to any Haas Product without the prior written authorization of Manufacturer, and/or (iv) any Haas Product was used for any non-commercial use (such as personal or household use). This warranty does not cover damage or defect due to an external influence or matters beyond the reasonable control of Manufacturer, including, but not limited to, theft, vandalism, fire, weather condition (such as rain, flood, wind, lightning, or earthquake), or acts of war or terrorism.

Without limiting the generality of any of the exclusions or limitations described in this Certificate, this warranty does not include any warranty that any Haas Product will meet any person's production specifications or other requirements, or that operation of any Haas Product will be uninterrupted or error-free. Manufacturer assumes no responsibility with respect to the use of any Haas Product by any person, and Manufacturer shall not incur any liability to any person for any failure in design, production, operation, performance, or otherwise of any Haas Product, other than repair or replacement of same as set forth in the warranty above.

## **Limitation of Liability and Damages**

Manufacturer will not be liable to Customer or any other person for any compensatory, incidental, consequential, punitive, special, or other damage or claim, whether in an action in contract, tort, or other legal or equitable theory, arising out of or related to any Haas product, other products or services provided by Manufacturer or an authorized distributor, service technician, or other authorized representative of Manufacturer (collectively, "authorized representative"), or the failure of parts or products made by using any Haas Product, even if Manufacturer or any authorized representative has been advised of the possibility of such damages, which damage or claim includes, but is not limited to, loss of profits, lost data, lost products, loss of revenue, loss of use, cost of down time, business good will, any damage to equipment, premises, or other property of any person, and any damage that may be caused by a malfunction of any Haas product. All such damages and claims are disclaimed by Manufacturer and waived by Customer. Manufacturer's sole liability, and Customer's exclusive remedy, for damages and claims for any cause whatsoever shall be limited to repair or replacement, at the discretion of Manufacturer, of the defective Haas Product as provided in this warranty.

---

Customer has accepted the limitations and restrictions set forth in this Certificate, including, but not limited to, the restriction on its right to recover damages, as part of its bargain with Manufacturer or its Authorized Representative. Customer realizes and acknowledges that the price of the Haas Products would be higher if Manufacturer were required to be responsible for damages and claims beyond the scope of this warranty.

### **Entire Agreement**

This Certificate supersedes any and all other agreements, promises, representations, or warranties, either oral or in writing, between the parties or by Manufacturer with respect to subject matter of this Certificate, and contains all of the covenants and agreements between the parties or by Manufacturer with respect to such subject matter. Manufacturer hereby expressly rejects any other agreements, promises, representations, or warranties, either oral or in writing, that are in addition to or inconsistent with any term or condition of this Certificate. No term or condition set forth in this Certificate may be modified or amended, unless by a written agreement signed by both Manufacturer and Customer. Notwithstanding the foregoing, Manufacturer will honor a Warranty Extension only to the extent that it extends the applicable warranty period.

### **Transferability**

This warranty is transferable from the original Customer to another party if the CNC Machine is sold via private sale before the end of the warranty period, provided that written notice thereof is provided to Manufacturer and this warranty is not void at the time of transfer. The transferee of this warranty will be subject to all terms and conditions of this Certificate.

### **Miscellaneous**

This warranty shall be governed by the laws of the State of California without application of rules on conflicts of laws. Any and all disputes arising from this warranty shall be resolved in a court of competent jurisdiction located in Ventura County, Los Angeles County, or Orange County, California. Any term or provision of this Certificate that is invalid or unenforceable in any situation in any jurisdiction shall not affect the validity or enforceability of the remaining terms and provisions hereof, or the validity or enforceability of the offending term or provision in any other situation or in any other jurisdiction.

---

# Customer Feedback

If you have concerns or questions regarding this Operator's Manual, please contact us on our website, [www.HaasCNC.com](http://www.HaasCNC.com). Use the "Contact Haas" link and send your comments to the Customer Advocate.

You can find an electronic copy of this manual and other useful information on our website in the "Resource Center". Join Haas owners online and be a part of the greater CNC community at these sites:



**[diy.haascnc.com](http://diy.haascnc.com)**

The Haas Resource Center: Documentation and Procedures



**[atyourservice.haascnc.com](http://atyourservice.haascnc.com)**

At Your Service: The Official Haas Answer and Information Blog



**[www.facebook.com/HaasAutomationInc](http://www.facebook.com/HaasAutomationInc)**

Haas Automation on Facebook



**[www.twitter.com/Haas\\_Automation](http://www.twitter.com/Haas_Automation)**

Follow us on Twitter



**[www.linkedin.com/company/haas-automation](http://www.linkedin.com/company/haas-automation)**

Haas Automation on LinkedIn



**[www.youtube.com/user/haasautomation](http://www.youtube.com/user/haasautomation)**

Product videos and information



**[www.flickr.com/photos/haasautomation](http://www.flickr.com/photos/haasautomation)**

Product photos and information



---

# Customer Satisfaction Policy

Dear Haas Customer,

Your complete satisfaction and goodwill are of the utmost importance to both Haas Automation, Inc. and the Haas distributor (HFO) where you purchased your equipment. Normally, your HFO will rapidly resolve any concerns you have about your sales transaction or the operation of your equipment.

However, if your concerns are not resolved to your complete satisfaction, and you have discussed your concerns with a member of the HFO's management, the General Manager, or the HFO's owner directly, please do the following:

Contact Haas Automation's Customer Service Advocate at 805-988-6980. So that we may resolve your concerns as quickly as possible, please have the following information available when you call:

- Your company name, address, and phone number
- The machine model and serial number
- The HFO name, and the name of your latest contact at the HFO
- The nature of your concern

If you wish to write Haas Automation, please use this address:

Haas Automation, Inc. U.S.A.  
2800 Sturgis Road  
Oxnard CA 93030  
Att: Customer Satisfaction Manager  
email: [customerservice@HaasCNC.com](mailto:customerservice@HaasCNC.com)

Once you contact the Haas Automation Customer Service Center, we will make every effort to work directly with you and your HFO to quickly resolve your concerns. At Haas Automation, we know that a good Customer-Distributor-Manufacturer relationship will help ensure continued success for all concerned.

International:

Haas Automation, Europe  
Mercuriusstraat 28, B-1930  
Zaventem, Belgium  
email: [customerservice@HaasCNC.com](mailto:customerservice@HaasCNC.com)

Haas Automation, Asia  
No. 96 Yi Wei Road 67,  
Waigaoqiao FTZ  
Shanghai 200131 P.R.C.  
email: [customerservice@HaasCNC.com](mailto:customerservice@HaasCNC.com)



---

# Declaration of Conformity

Product: CNC Milling Centers (Vertical and Horizontal)\*

\*Including all options factory- or field-installed by a certified Haas Factory Outlet (HFO)

Manufactured By: Haas Automation, Inc.

2800 Sturgis Road, Oxnard, CA 93030 **805-278-1800**

We declare, in sole responsibility, that the above-listed products, to which this declaration refers, comply with the regulations as outlined in the CE directive for Machining Centers:

- Machinery Directive 2006/42/EC
- Electromagnetic Compatibility Directive 2004/108/EC
- Low Voltage Directive 2006/95/EC
- Additional Standards:
  - EN 60204-1:2006/A1:2009
  - EN 614-1:2006+A1:2009
  - EN 894-1:1997+A1:2008
  - EN 13849-1:2008/AC:2009
  - EN 14121-1:2007

RoHS: COMPLIANT by Exemption per producer documentation. Exempt by:

- a) Large scale stationary industrial tool
- b) Monitoring and control systems
- c) Lead as an alloying element in steel, aluminum, and copper

Person authorized to compile technical file:

Patrick Goris

Address: Haas Automation Europe  
Mercuriusstraat 28, B-1930  
Zaventem, Belgium

---

USA: Haas Automation certifies this machine to be in compliance with the OSHA and ANSI design and manufacturing standards listed below. Operation of this machine will be compliant with the below-listed standards only as long as the owner and operator continue to follow the operation, maintenance, and training requirements of these standards.

- *OSHA 1910.212 - General Requirements for All Machines*
- *ANSI B11.5-1983 (R1994) Drilling, Milling, and Boring Machines*
- *ANSI B11.19-2003 Performance Criteria for Safeguarding*
- *ANSI B11.23-2002 Safety Requirements for Machining Centers and Automatic Numerically Controlled Milling, Drilling, and Boring Machines*
- *ANSI B11.TR3-2000 Risk Assessment and Risk Reduction - A Guideline to Estimate, Evaluate, and Reduce Risks Associated with Machine Tools*

CANADA: As the original equipment manufacturer, we declare that the listed products comply with regulations as outlined in the Pre-Start Health and Safety Reviews Section 7 of Regulation 851 of the Occupational Health and Safety Act Regulations for Industrial Establishments for machine guarding provisions and standards.

Further, this document satisfies the notice-in-writing provision for exemption from Pre-Start inspection for the listed machinery as outlined in the Ontario Health and Safety Guidelines, PSR Guidelines dated April 2001. The PSR Guidelines allow that notice in writing from the original equipment manufacturer declaring conformity to applicable standards is acceptable for the exemption from Pre-Start Health and Safety Review.



All Haas CNC machine tools carry the ETL Listed mark, certifying that they conform to the NFPA 79 Electrical Standard for Industrial Machinery and the Canadian equivalent, CAN/CSA C22.2 No. 73. The ETL Listed and cETL Listed marks are awarded to products that have successfully undergone testing by Intertek Testing Services (ITS), an alternative to Underwriters' Laboratories.



The ISO 9001:2008 certification from ISA, Inc. (an ISO registrar) serves as an impartial appraisal of Haas Automation's quality management system. This achievement affirms Haas Automation's conformance with the standards set forth by the International Organization for Standardization, and acknowledges the Haas commitment to meeting the needs and requirements of its customers in the global marketplace.

## Original Instructions

---





# How to Use This Manual

To get the maximum benefit of your new Haas machine, read this manual thoroughly and refer to it often. The content of this manual is also available on your machine control under the HELP function.

**IMPORTANT:** Before you operate the machine, read and understand the Operator's Manual Safety chapter.

## Declaration of Warnings

Throughout this manual, important statements are set off from the main text with an icon and an associated signal word: "Danger," "Warning," "Caution," or "Note." The icon and signal word indicate the severity of the condition or situation. Be sure to read these statements and take special care to follow the instructions.

Description	Example
<p><b>Danger</b> means that there is a condition or situation that <b>will cause death or severe injury</b> if you do not follow the instructions given.</p>	 <p><b>DANGER:</b> No step. Risk of electrocution, bodily injury, or machine damage. Do not climb or stand on this area.</p>
<p><b>Warning</b> means that there is a condition or situation that <b>will cause moderate injury</b> if you do not follow the instructions given.</p>	 <p><b>WARNING:</b> Never put your hands between the tool changer and the spindle head.</p>
<p><b>Caution</b> means that <b>minor injury or machine damage could occur</b> if you do not follow the instructions given. You may also have to start a procedure over if you do not follow the instructions in a caution statement.</p>	 <p><b>CAUTION:</b> Power down the machine before you do maintenance tasks.</p>
<p><b>Note</b> means that the text gives <b>additional information, clarification, or helpful hints</b>.</p>	 <p><b>NOTE:</b> Follow these guidelines if the machine is equipped with the optional extended Z-clearance table.</p>

---

## Text Conventions Used in this Manual

Description	Text Example
<b>Code Block</b> text gives program examples.	G00 G90 G54 X0. Y0.;
A <b>Control Button Reference</b> gives the name of a control key or button that you are to press.	Press <b>[CYCLE START]</b> .
A <b>File Path</b> describes a sequence of file system directories.	<i>Service &gt; Documents and Software &gt;...</i>
A <b>Mode Reference</b> describes a machine mode.	MDI
A <b>Screen Element</b> describes an object on the machine's display that you interact with.	Select the <b>SYSTEM</b> tab.
<b>System Output</b> describes text that the machine control displays in response to your actions.	PROGRAM END
<b>User Input</b> describes text that you should enter into the machine control.	G04 P1.;
<b>Variable</b> n indicates a range of non-negative integers from 0 to 9.	Dnn represents D00 through D99.

---

# Contents

<b>Chapter 1</b>	<b>Safety</b>	<b>1</b>
1.1	Introduction	1
1.1.1	Read Before Operating	1
1.1.2	Environmental and Noise Limits	3
1.2	Unattended Operation	4
1.3	Setup Mode	4
1.3.1	Robot Cells	5
1.3.2	Machine Behavior with the Door Open	5
1.4	Modifications to the Machine	8
1.5	Safety Decals	8
1.5.1	Mill Warning Decals	9
1.5.2	Other Safety Decals	10
1.6	More Information Online	11
<b>Chapter 2</b>	<b>Introduction</b>	<b>13</b>
2.1	Vertical Mill Orientation	13
2.2	Horizontal Mill Orientation	18
2.3	Control Pendant	32
2.3.1	Pendant Front Panel	32
2.3.2	Pendant Right Side, Top, and Bottom Panels	33
2.3.3	Keyboard	34
2.3.4	Control Display	45
2.3.5	Screen Capture	65
2.4	Tabbed Menu Basic Navigation	65
2.5	Help	66
2.5.1	The Help Tabbed Menu	67
2.5.2	Search Tab	67
2.5.3	Help Index	68
2.5.4	Drill Table Tab	68
2.5.5	Calculator Tab	68
2.6	More Information Online	74
<b>Chapter 3</b>	<b>Operation</b>	<b>75</b>
3.1	Machine Power-Up	75
3.2	Spindle Warm-Up Program	75
3.3	Device Manager	76
3.3.1	File Directory Systems	77

3.3.2	Program Selection . . . . .	77
3.3.3	Program Transfer . . . . .	78
3.3.4	Deleting Programs . . . . .	79
3.3.5	Maximum Number of Programs . . . . .	80
3.3.6	File Duplication . . . . .	80
3.3.7	Changing Program Numbers . . . . .	80
3.4	Basic Program Search. . . . .	81
3.5	RS-232 . . . . .	81
3.5.1	Cable Length . . . . .	82
3.5.2	Machine Data Collection. . . . .	82
3.6	File Numeric Control (FNC) . . . . .	84
3.7	Direct Numeric Control (DNC). . . . .	85
3.7.1	DNC Notes. . . . .	86
3.8	Graphics Mode . . . . .	86
3.9	Tooling. . . . .	87
3.9.1	Tool Functions (Tnn). . . . .	87
3.9.2	Tool Holders . . . . .	88
3.9.3	Advanced Tool Management Introduction. . . . .	91
3.10	Tool Changer . . . . .	95
3.10.1	Tool Changer Safety Notes . . . . .	96
3.10.2	Loading the Tool Changer . . . . .	96
3.10.3	Umbrella Tool Changer Recovery . . . . .	102
3.10.4	Side Mount Tool Changer Recovery. . . . .	102
3.10.5	Side Mount Tool Changer Door and Switch Panel . . . . .	103
3.11	Part Setup . . . . .	103
3.12	Setting Offsets. . . . .	104
3.12.1	Jog Mode . . . . .	104
3.12.2	Typical Work Offset Set-up . . . . .	105
3.12.3	Setting the Tool Offset. . . . .	106
3.12.4	Additional Tooling Set-up . . . . .	107
3.13	Dry Run Operation. . . . .	107
3.14	Running Programs. . . . .	107
3.15	Run-Stop-Jog-Continue . . . . .	108
3.16	Axis Overload Timer. . . . .	109
3.17	More Information Online. . . . .	109

<b>Chapter 4</b>	<b>Programming . . . . .</b>	<b>111</b>
4.1	Numbered Programs . . . . .	111
4.2	Program Editors . . . . .	111
4.2.1	Basic Program Editing . . . . .	111
4.2.2	Background Edit . . . . .	113
4.2.3	Manual Data Input (MDI) . . . . .	114
4.2.4	Advanced Editor . . . . .	115



	<b>4.2.5</b>	The FNC Editor . . . . .	124
<b>4.3</b>		Fadal Program Converter . . . . .	135
<b>4.4</b>		Program Optimizer . . . . .	137
	<b>4.4.1</b>	Program Optimizer Operation . . . . .	137
<b>4.5</b>		DXF File Importer . . . . .	138
	<b>4.5.1</b>	Part Origin . . . . .	139
	<b>4.5.2</b>	Part Geometry Chain and Group . . . . .	139
	<b>4.5.3</b>	Toolpath Selection . . . . .	140
<b>4.6</b>		Basic Programming . . . . .	140
	<b>4.6.1</b>	Preparation . . . . .	142
	<b>4.6.2</b>	Cutting . . . . .	143
	<b>4.6.3</b>	Completion. . . . .	143
	<b>4.6.4</b>	Absolute vs. Incremental (G90, G91) . . . . .	143
<b>4.7</b>		Tool and Work Offset Calls . . . . .	146
	<b>4.7.1</b>	G43 Tool Offset . . . . .	146
	<b>4.7.2</b>	G54 Work Offsets . . . . .	146
<b>4.8</b>		Miscellaneous Codes . . . . .	147
	<b>4.8.1</b>	Tool Change Command . . . . .	147
	<b>4.8.2</b>	Spindle Commands . . . . .	147
	<b>4.8.3</b>	Program Stop Commands . . . . .	147
	<b>4.8.4</b>	Coolant Commands . . . . .	148
<b>4.9</b>		Cutting G-codes . . . . .	148
	<b>4.9.1</b>	Linear Interpolation Motion . . . . .	148
	<b>4.9.2</b>	Circular Interpolation Motion. . . . .	149
<b>4.10</b>		Cutter Compensation . . . . .	150
	<b>4.10.1</b>	General Description of Cutter Compensation . . . . .	151
	<b>4.10.2</b>	Entry and Exit from Cutter Compensation . . . . .	154
	<b>4.10.3</b>	Feed Adjustments in Cutter Compensation . . . . .	155
	<b>4.10.4</b>	Circular Interpolation and Cutter Compensation. . . . .	157
<b>4.11</b>		Canned Cycles . . . . .	160
	<b>4.11.1</b>	Drilling Canned Cycles. . . . .	160
	<b>4.11.2</b>	Tapping Canned Cycles . . . . .	160
	<b>4.11.3</b>	Boring and Reaming Cycles . . . . .	160
	<b>4.11.4</b>	R Planes . . . . .	161
<b>4.12</b>		Special G-codes . . . . .	161
	<b>4.12.1</b>	Engraving . . . . .	161
	<b>4.12.2</b>	Pocket Milling . . . . .	162
	<b>4.12.3</b>	Rotation and Scaling. . . . .	162
	<b>4.12.4</b>	Mirror Image . . . . .	162
<b>4.13</b>		Subroutines . . . . .	163
	<b>4.13.1</b>	External Subroutine (M98). . . . .	163
	<b>4.13.2</b>	Local Subroutine (M97) . . . . .	165
	<b>4.13.3</b>	External Subroutine Canned Cycle Example (M98) . . . . .	166

	<b>4.13.4</b>	External Subroutines With Multiple Fixtures (M98) . . .	166
	<b>4.14</b>	More Information Online . . . . .	167
<b>Chapter 5</b>	<b>Options Programming</b>	. . . . .	<b>169</b>
	<b>5.1</b>	Options Programming . . . . .	169
	<b>5.2</b>	4th and 5th Axis Programming . . . . .	169
		<b>5.2.1</b> Creating Five-Axis Programs . . . . .	169
		<b>5.2.2</b> Installing an Optional 4th Axis . . . . .	173
		<b>5.2.3</b> Installing an Optional 5th Axis . . . . .	175
		<b>5.2.4</b> B on A Axis Offset (Tilting Rotary Products). . . . .	175
		<b>5.2.5</b> Disabling 4th and 5th Axes . . . . .	177
	<b>5.3</b>	Macros (Optional) . . . . .	178
		<b>5.3.1</b> Macros Introduction . . . . .	178
		<b>5.3.2</b> Operation Notes . . . . .	181
		<b>5.3.3</b> System Variables In-Depth . . . . .	193
		<b>5.3.4</b> Variable Usage . . . . .	202
		<b>5.3.5</b> Address Substitution. . . . .	203
		<b>5.3.6</b> G65 Macro Subroutine Call Option (Group 00) . . . . .	214
		<b>5.3.7</b> Communication With External Devices - DPRNT[ ] . . . . .	216
	<b>5.4</b>	Fanuc-Style Macros Not Included . . . . .	218
	<b>5.5</b>	Programmable Coolant (P-Cool) . . . . .	220
		<b>5.5.1</b> P-Cool Positioning . . . . .	220
	<b>5.6</b>	Servo Auto Door. . . . .	222
	<b>5.7</b>	Through-Spindle Coolant (TSC). . . . .	223
	<b>5.8</b>	Other Options . . . . .	223
		<b>5.8.1</b> Wireless Intuitive Probing System (WIPS). . . . .	223
		<b>5.8.2</b> Intuitive Programming System (IPS). . . . .	223
	<b>5.9</b>	More Information Online. . . . .	224
<b>Chapter 6</b>	<b>G-codes, M-codes, Settings</b>	. . . . .	<b>225</b>
	<b>6.1</b>	Introduction . . . . .	225
	<b>6.2</b>	G-codes . . . . .	225
	<b>6.3</b>	M-codes . . . . .	319
	<b>6.4</b>	Settings . . . . .	337
	<b>6.5</b>	More Information Online. . . . .	374
<b>Chapter 7</b>	<b>Maintenance</b>	. . . . .	<b>375</b>
	<b>7.1</b>	Introduction . . . . .	375
	<b>7.2</b>	Daily Maintenance. . . . .	375
	<b>7.3</b>	Weekly Maintenance . . . . .	375
	<b>7.4</b>	Monthly Maintenance . . . . .	376
	<b>7.5</b>	Every (6) Months . . . . .	376
	<b>7.6</b>	Annual Maintenance. . . . .	376

---

**Chapter 8 Other Machine Manuals . . . . .377**

- 8.1** Introduction . . . . . 377
- 8.2** Mini Mills . . . . . 377
- 8.3** VF-Trunnion Series . . . . . 377
- 8.4** Gantry Routers . . . . . 377
- 8.5** Office Mill . . . . . 377
- 8.6** EC-400 Pallet Pool . . . . . 377
- 8.7** UMC-750 . . . . . 377

**Index . . . . .379**



# Chapter 1: Safety

## 1.1 Introduction

**CAUTION:**

*Only authorized and trained personnel may operate this equipment. You must always act in accordance with the Operator's manual, safety decals, safety procedures and instructions for safe machine operation. Untrained personnel present a hazard to themselves and the machine.*

**IMPORTANT:**

*Read and understand all warnings, cautions, and instructions before operating this machine.*

All milling machines present hazards from rotating cutting tools, belts and pulleys, high voltage electricity, noise, and compressed air. When you use CNC machines and their components, you must always follow basic safety precautions to reduce the risk of personal injury and mechanical damage.

### 1.1.1 Read Before Operating

**DANGER:**

*Do not enter the machining area any time the machine is in motion. Severe injury or death may result.*

Basic safety:

- Consult your local safety codes and regulations before operating the machine. Contact your dealer any time safety issues need to be addressed.
- It is the shop owner's responsibility to make sure that everyone who is involved in installing and operating the machine is thoroughly acquainted with the operation and safety instructions provided with the machine BEFORE they perform any actual work. The ultimate responsibility for safety rests with the shop owner and the individuals who work with the machine.
- Use appropriate eye and ear protection while operating the machine. ANSI-approved impact safety goggles and OSHA-approved ear protection are recommended to reduce the risks of sight damage and hearing loss.
- This machine is automatically controlled and may start at any time.
- This machine can cause severe bodily injury.

- Replace damaged windows immediately if they are damaged or severely scratched. Keep the side windows locked during operation of the machine (if available).
- As sold, your machine is not equipped to process toxic or flammable material; this can create deadly fumes or suspended particles in the air. Consult with the material manufacturer for safe handling of material by-products, and implement all precautions before you work with such materials.

### Electrical safety:

- The electrical power must meet the required specifications. Attempting to run the machine from any other source can cause severe damage and will void the warranty.
- The electrical panel should be closed and the key and latches on the control cabinet should be secured at all times, except during installation and service. At those times, only qualified electricians should have access to the panel. When the main circuit breaker is on, there is high voltage throughout the electrical panel (including the circuit boards and logic circuits) and some components operate at high temperatures; therefore, extreme caution is required. Once the machine is installed, the control cabinet must be locked, with the key available only to qualified service personnel.
- Do not reset a circuit breaker until the reason for the fault is investigated and understood. Only Haas-trained service personnel should troubleshoot and repair the equipment.
- Never service the machine with the power connected.
- Do not press **[POWER UP/RESTART]** on the control pendant before the machine is fully installed.

### Operation Safety:

- Do not operate the machine unless the doors are closed and the door interlocks are functioning properly. Rotating cutting tools can cause severe injury. When a program runs, the mill table and spindle head can move rapidly at any time, and in any direction.
- **[EMERGENCY STOP]** is the large, circular red button located on the control pendant. Some machines may also have buttons in other locations. When you press **[EMERGENCY STOP]**, the axis motors, spindle motor, pumps, tool changer, and gear motors all stop. While **[EMERGENCY STOP]** is active, both automatic and manual motion is disabled. Use **[EMERGENCY STOP]** in case of emergency, and also to disable the machine for safety when you need to access motion areas.
- Check for damaged parts and tools before operating the machine. Any part or tool that is damaged should be properly repaired or replaced by authorized personnel. Do not operate the machine if any component does not appear to be functioning correctly.
- Keep your hands away from the tool in the spindle when you press **[ATC FWD]**, **[ATC REV]**, **[NEXT TOOL]**, or cause a tool change cycle. The tool changer will move in and crush your hand.
- The spindle head can drop without notice. You must avoid the area directly under the spindle head.

- To prevent tool changer damage, make sure that tools are properly aligned with the spindle drive lugs when you load tools.

**DANGER:**

*Improperly clamped parts or oversized parts may be ejected with deadly force. The machine enclosure may not stop an ejected part.*

Follow these guidelines while you work with the machine:

- Normal operation – Keep the door closed and guards in place while the machine operates.
- Part loading and unloading – An operator opens the door or guard, completes a task, closes the door or guard, then presses **[CYCLE START]** (which starts automatic motion).
- Tool loading and unloading – A machinist enters the machining area to load or unload tools. Exit the area completely before automatic movement is commanded (for example, **[NEXT TOOL]**, **[ATC FWD]**, **[ATC REV]**).
- Machining job set-up – Press **[EMERGENCY STOP]** before adding or removing machine fixtures.
- Maintenance / Machine Cleaner – Press **[EMERGENCY STOP]** or **[POWER OFF]** on the machine before entering enclosure.

## 1.1.2 Environmental and Noise Limits

The following table lists the environmental and noise limits for safe operation:

**T1.1:** Environmental and Noise Limits

	Minimum	Maximum
Environmental (Indoor Use Only)*		
Operating Temperature	41 °F (5 °C)	122 °F (50 °C)
Storage Temperature	-4 °F (-20 °C)	158 °F (70 °C)
Ambient Humidity	20% relative, non-condensing	90% relative, non-condensing
Altitude	Sea level	6,000 ft. (1,829 m)

	Minimum	Maximum
Noise		
Emitted from all areas of machine during use at a typical operator's position	70 dB	Greater than 85 dB

\* Do not operate the machine in explosive atmospheres (explosive vapors and/ or particulate matter).

\*\* Take precautions to prevent hearing damage from machine/machining noise. Wear ear protection, change your application (tooling, spindle speed, axis speed, fixturing, programmed path) to reduce noise, or restrict access to machine area during cutting.

## 1.2 Unattended Operation

Fully enclosed Haas CNC machines are designed to operate unattended; however, your machining process may not be safe to operate unmonitored.

As it is the shop owner's responsibility to set up the machine safely and use best practice machining techniques, it is also their responsibility to manage the progress of these methods. The machining process must be monitored to prevent damage if a hazardous condition occurs.

For example, if there is the risk of fire due to the material machined, then you must install an appropriate fire suppression system to reduce the risk of harm to personnel, equipment and the building. Contact a specialist to install monitoring tools before machines are allowed to run unattended.

It is especially important to select monitoring equipment that can immediately perform an appropriate action without human intervention to prevent an accident, should a problem be detected.

## 1.3 Setup Mode

All Haas CNC machines are equipped with locks on the operator doors and a key switch on the side of the control pendant to lock and unlock setup mode. Generally, setup mode status (locked or unlocked) affects how the machine operates when the doors are opened.

Setup mode should be locked out (the keyswitch in the vertical, locked position) at most times. In locked mode, the enclosure doors are locked closed during CNC program execution, spindle rotation or axis movement. The doors automatically unlock when the machine is not in cycle. Many machine functions are unavailable with the door open.



When unlocked, setup mode allows a skilled machinist more access to the machine to set up jobs. In this mode, machine behavior is dependent on whether the doors are opened or closed. Opening the doors when the machine is in cycle stops motion and reduces spindle speed. The machine allows several functions in setup mode with the doors opened, usually at reduced speed. The following charts summarize the modes and allowed functions.

**DANGER:**

*Do not attempt to override safety features. Doing so will make the machine unsafe and void the warranty.*

### 1.3.1 Robot Cells

A machine in a robot cell is allowed to run, unrestricted, with the door open while in lock/run mode.

This open-door condition is only allowed while a robot is communicating with the CNC machine. Typically, an interface between the robot and the CNC machine addresses the safety of both machines.

Robot cell setup is beyond the scope of this manual. Work with a robot-cell integrator and your HFO to correctly set up a safe robot cell.

### 1.3.2 Machine Behavior with the Door Open

For safety, machine operations are stopped when the door is open and the setup keyswitch is locked. The unlock position permits limited machine functions.





#### T1.2: Setup / Run Mode Limited Overrides with the Machine Doors Open

Machine Function	Locked (Run Mode)	Unlocked (Setup Mode)
Maximum Rapid	Not allowed.	Not allowed.
Cycle Start	Not allowed. No machine motion or program execution.	Not allowed. No machine motion or program execution.
Spindle <b>[CW]</b> / <b>[CCW]</b>	Allowed, but you must press and hold <b>[CW]</b> or <b>[CCW]</b> . Maximum 750 RPM.	Allowed, but maximum 750 RPM.
Tool Change	Not allowed.	Not allowed.
Next Tool feature	Not allowed.	Not allowed.

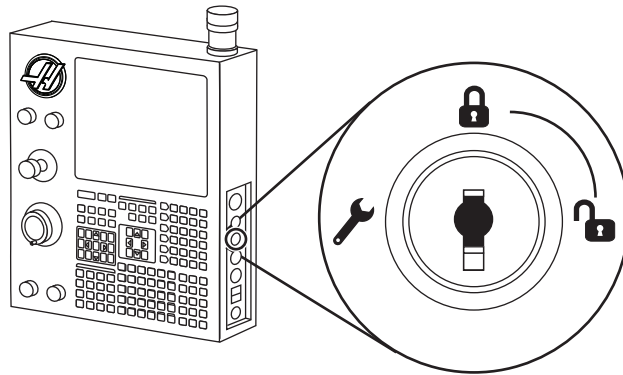

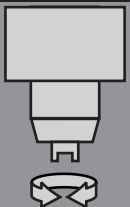
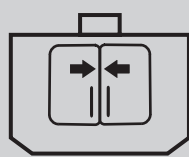
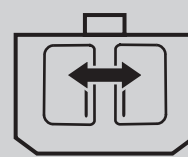

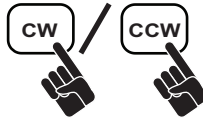
Machine Function	Locked (Run Mode)	Unlocked (Setup Mode)
Opening doors while a program runs	Not allowed. The door is locked.	Allowed, but axis motion will stop and the spindle will slow to a maximum of 750 RPM.
Conveyor motion	Allowed, but you must press and hold <b>[CHIP REV]</b> to run in reverse.	Allowed, but you must press and hold <b>[CHIP REV]</b> to run in reverse.

F1.1: Spindle Control, Setup and Run Mode



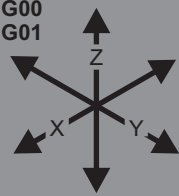

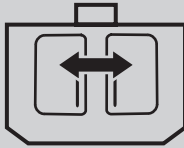

		
	100%	 750 RPM
	100%	750 RPM

**F1.2:** Axis Motion Rates, Setup and Run Mode

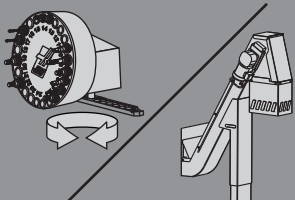
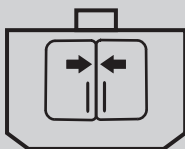
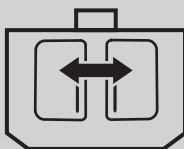
		
	<p>100%</p>	<p>0%</p>
	<p>100%</p>	<p>0%</p>

**F1.3:** Tool Change and Conveyor Control, Setup and Run Mode.

		
	<p>100%</p>	<p>✗</p> <p>                        CHIP FWD 100%                      CHIP REV                 </p>
	<p>100%</p>	<p>✗</p> <p>                        CHIP FWD 100%                      CHIP REV                 </p>

## 1.4 Modifications to the Machine

DO NOT modify or alter this equipment in any way. Your Haas Factory Outlet (HFO) must handle all modification requests. Modification or alteration of any Haas machine without factory authorization could lead to personal injury and mechanical damage, and will void your warranty.

## 1.5 Safety Decals

To help ensure that CNC machine dangers are quickly communicated and understood, hazard symbol decals are placed on Haas Machines in locations where hazards exist. If decals become damaged or worn, or if additional decals are needed to emphasize a particular safety point, contact your dealer or the Haas factory.



### NOTE:

*Never alter or remove any safety decal or symbol.*

Each hazard is defined and explained on the general safety decal, located at the front of the machine. Review and understand the four parts of each safety warning, explained below, and familiarize yourself with the symbols in this section.

### F1.4: Standard Warning Layout

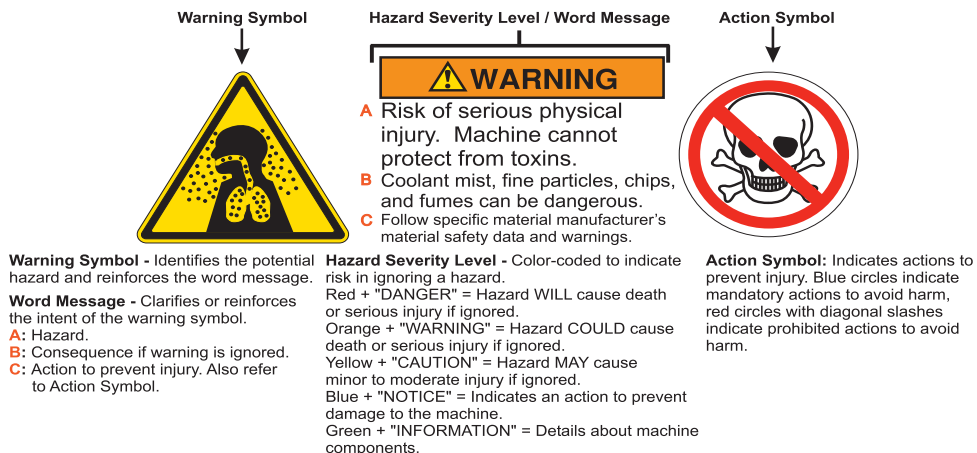

## 1.5.1 Mill Warning Decals

This is an example of a general mill warning decal in English. You can contact your Haas Factory Outlet (HFO) to get these decals in other languages.

### F1.5: Mill Warning Decal Example

<b>⚠ DANGER</b>			
	<p><b>Electrocution hazard.</b> Death by electric shock can occur. Turn off and lock out system power before servicing.</p>		<p><b>Automatic Machine may start at any time.</b> Injury or death could be caused by untrained operator. Read and understand operator's manual and safety signs before using this machine.</p>
	<p><b>Risk of serious physical injury. Machine cannot protect from toxins.</b> Coolant mist, fine particles, chips, and fumes can be dangerous. Follow specific material manufacturer's material safety data and warnings.</p>		<p><b>Risk of serious bodily injury.</b> The enclosure may not stop every type of projectile. Double-check job set up before beginning any machining operations. Always follow safe machining practices. Do not operate with doors or windows open or guards removed.</p>
	<p><b>Risk of fire and explosion.</b> Machine is not designed to resist or contain blasts or fire. Do not machine explosive or flammable materials or coolants. Refer to specific material manufacturer's material safety data and warnings.</p>		<p><b>Risk of bodily injury.</b> Serious cuts, abrasions, and physical injury may result from slips and falls. Avoid using the machine in wet, damp, or poorly lit areas.</p>
	<p><b>Severe injury can occur.</b> Moving parts can entangle, trap, and cut. Sharp tools or chips can cut skin easily. Ensure the machine is not in automatic operation before reaching inside.</p>		<p><b>Risk of eye and ear injury.</b> Flying debris into unprotected eyes can cause loss of sight. Noise levels can exceed 70 dBA. Must wear safety glasses and hearing protection when operating or in the area of machine.</p>
<p>Safety windows may become brittle and lose effectiveness when exposed to machine coolants and oils over time. If signs of discoloration, crazing, or cracking are found, replace immediately. Safety windows should be replaced every two years.</p>			
<b>⚠ WARNING</b>			
	<p><b>Severe injury can occur.</b> Moving parts can entangle and trap. Always secure loose clothing and long hair.</p>		<p><b>Risk of serious bodily injury.</b> Follow safe clamping practices. Inadequately clamped parts can be thrown with deadly force. Securely clamp workpieces and fixtures.</p>
	<p><b>Impact hazard.</b> Machine components can crush and cut. Do not handle any part of the machine during automatic operation. Always keep clear of moving parts.</p>		<p><b>Moving parts can crush.</b> The tool changer will move in and crush your hand. Never place your hand on the spindle and press ATC FWD, ATC REV, NEXT TOOL, or cause a tool change cycle.</p>
<ul style="list-style-type: none"> <li>• Do not allow untrained personnel to operate this machine.</li> <li>• Do not alter or modify machine in any way.</li> <li>• Do not operate this machine with worn or damaged components.</li> <li>• No user serviceable parts inside. Machine must be repaired or serviced by authorized service technicians only.</li> </ul>			
<b>NOTICE</b>			
 <p>Coolant Tank Maintenance Gate Filter</p>	<p>Clean the filter screen weekly. Remove the coolant tank cover and clean out any sediment inside the tank weekly. Do not use plain water, permanent corrosion damage will result. Rust inhibiting coolant is required. Do not use toxic or flammable liquids as a coolant.</p>		

## 1.5.2 Other Safety Decals

You may find other decals on your machine, depending on the model and options installed. Be sure to read and understand these decals. These are examples of other safety decals in English. You can contact your Haas Factory Outlet (HFO) to get these decals in other languages.

### F1.6: Other Safety Decal Examples



---

## 1.6 More Information Online

For updated and supplemental information, including tips, tricks, maintenance procedures, and more, go to [www.HaasCNC.com](http://www.HaasCNC.com) and select the **Resource Center**.





# Chapter 2: Introduction

## 2.1 Vertical Mill Orientation

The following figures show some of the standard and optional features of your Haas Vertical Mill. Note that these figures are representative only; your machine's appearance may vary depending on the model and installed options.

**F2.1:** Vertical Mill Features (front view)

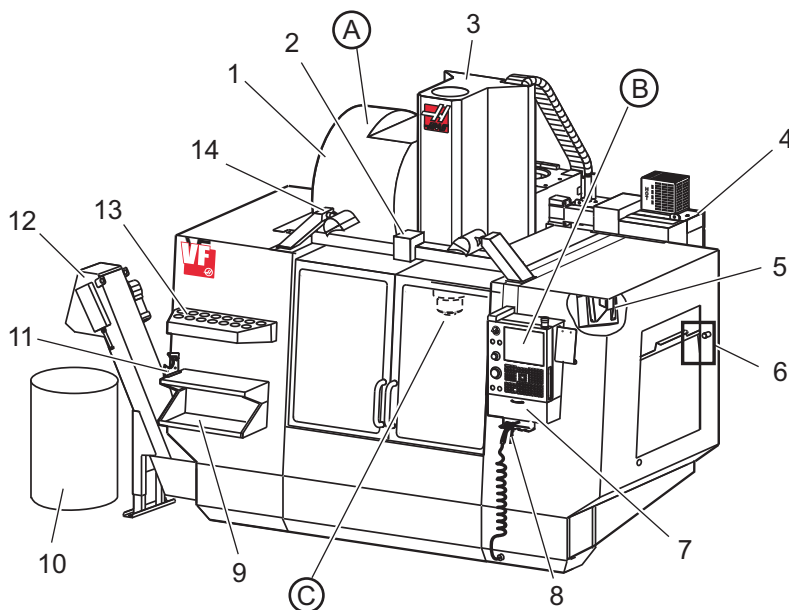

- |   |                          |
|---|--------------------------|
| 1. Side Mount Tool Changer (optional)     | A. Umbrella Tool Changer |
| 2. Servo Auto Door (optional)             | B. Control Pendant       |
| 3. Spindle Assembly                       | C. Spindle Head Assembly |
| 4. Electrical Control Box                 |                          |
| 5. Work Light (2X)                        |                          |
| 6. Window Controls                        |                          |
| 7. Storage Tray                           |                          |
| 8. Air Gun                                |                          |
| 9. Front Work Table                       |                          |
| 10. Chip Container                        |                          |
| 11. Tool Holding Vise                     |                          |
| 12. Chip Conveyor (optional)              |                          |
| 13. Tool Tray                             |                          |
| 14. High Intensity Lights (2X) (optional) |                          |

---

**F2.2: Detail A**

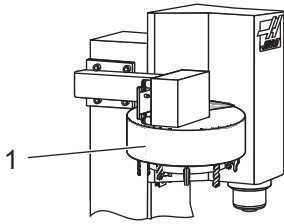

1. Umbrella-Style Tool Changer

**F2.3: Detail B**

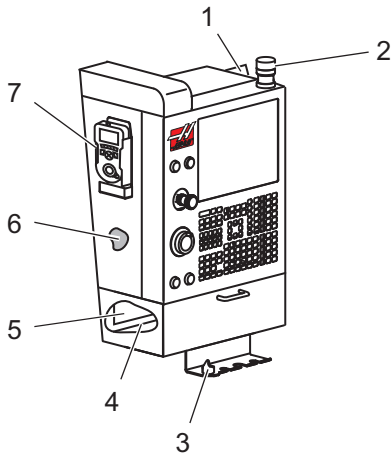

1. Clipboard
2. Work Beacon
3. Vise Handle Holder
4. Tool Tray
5. G- and M-code Reference List
6. Operator's Manual and Assembly Data (stored inside)
7. Remote Jog Handle

**F2.4: Detail C**

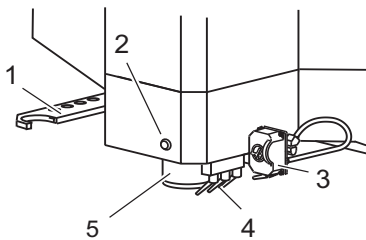

1. SMT Double Arm (if equipped)
2. Tool Release Button
3. Programmable Coolant (optional)
4. Coolant Nozzles
5. Spindle

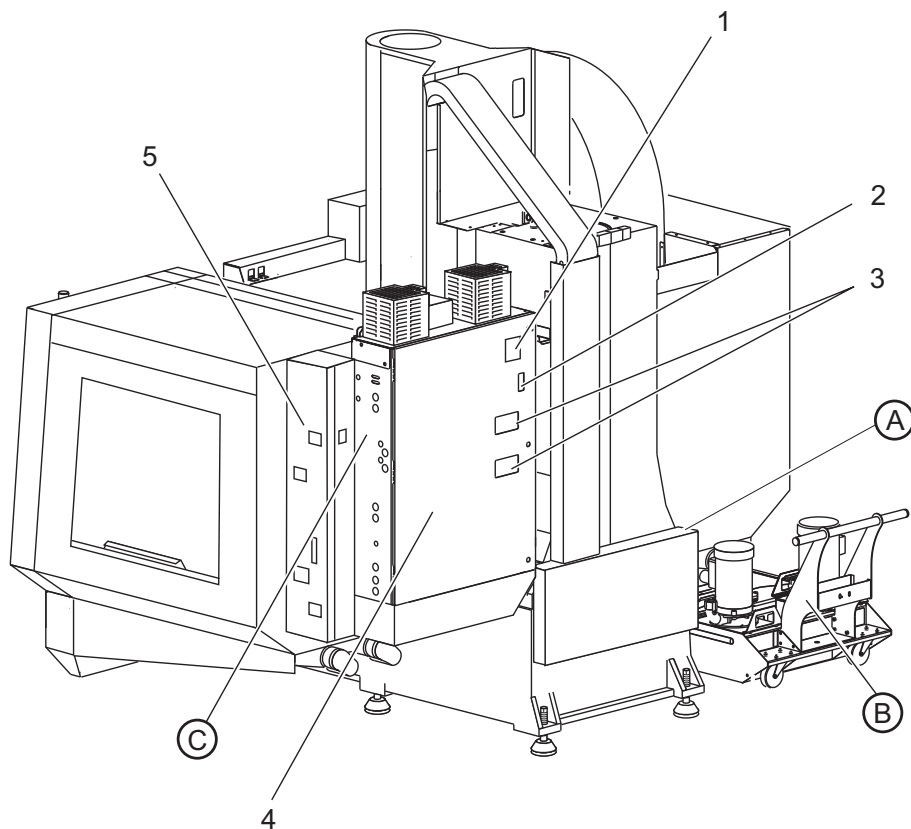
**F2.5:** Vertical Mill Features (rear view)

1. Data Plate
2. Main Circuit Breaker Switch
3. Vector Drive Fan (runs intermittently)
4. Control Cabinet
5. Smart Lube Panel Assembly

- A Electrical Connectors  
B Coolant Tank Assembly  
C Electrical Control Cabinet Side Panel

---

**F2.6: Detail A - Electrical Connectors**

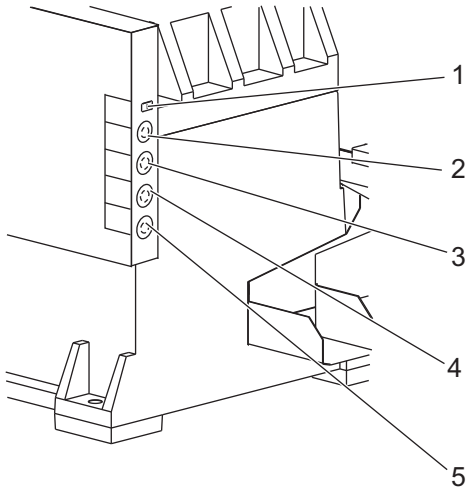

1. Coolant Level Sensor
2. Coolant (Optional)
3. Auxiliary Coolant (Optional)
4. Washdown (Optional)
5. Conveyor (Optional)

**F2.7: Detail B**

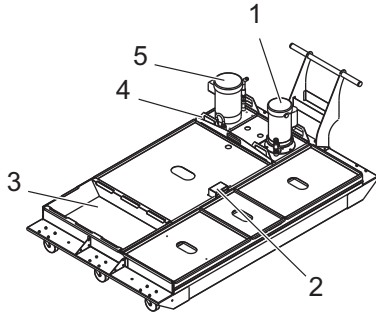

1. Standard Coolant Pump
2. Coolant Level Sensor
3. Chip Tray
4. Strainer
5. Through-Spindle Coolant Pump

F2.8: Detail C

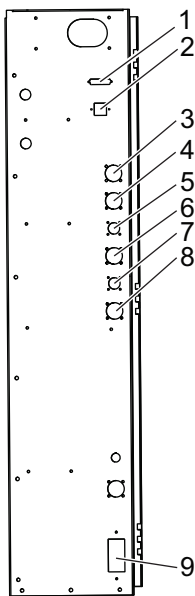

1. RS-232 (Optional)
2. Enet (Optional)
3. Scale A-Axis (Optional)
4. Scale B-Axis (Optional)
5. A-Axis Power (Optional)
6. A-Axis Encoder (Optional)
7. B-Axis Power (Optional)
8. B-Axis Encoder (Optional)
9. 115 VAC @ 5A

## 2.2 Horizontal Mill Orientation

The following figures show some of the standard and optional features of your Haas Horizontal Mill. Note that these figures are representative only; your machine's appearance may vary depending on the model and installed options.

**F2.9:** Horizontal Mill Features (EC-300 to EC-500, front view)

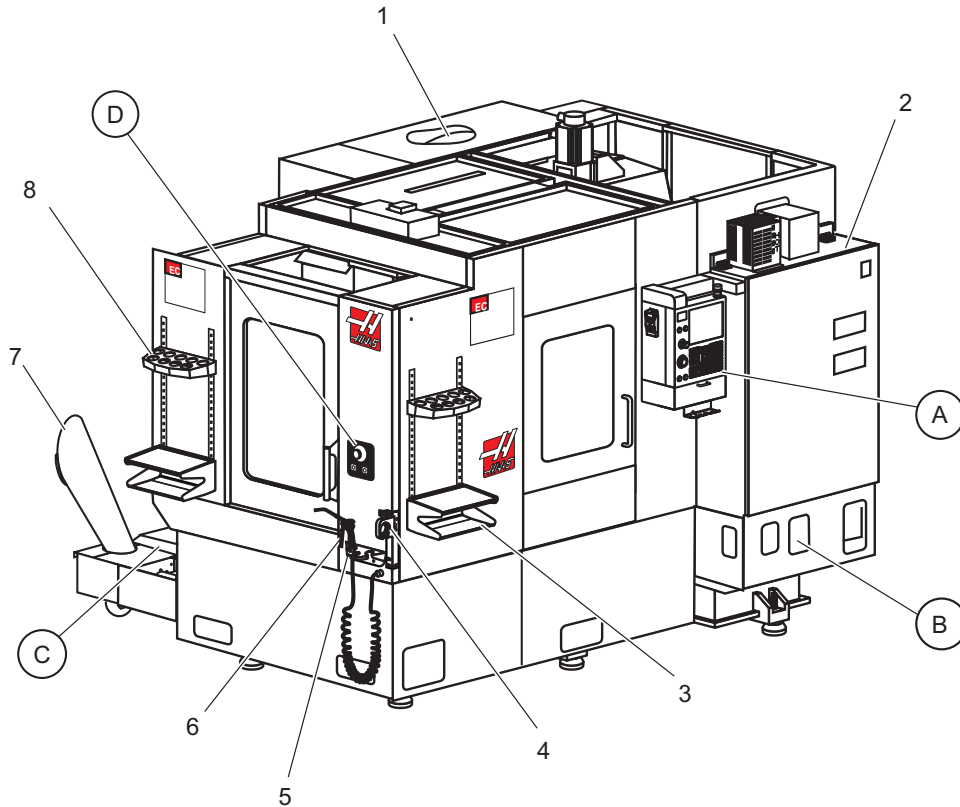

- |  |                           |
|--|---------------------------|
| 1. Side Mount Tool Changer SMTC (optional) | A Control Pendant         |
| 2. Electrical Control Box                  | B Air Supply Assembly     |
| 3. Front Work Table                        | C Coolant Tank Assembly   |
| 4. Tool Holding Vise                       | D Pallet Changer Controls |
| 5. Storage Tray                            |                           |
| 6. Air Gun                                 |                           |
| 7. Chip Conveyor (optional)                |                           |
| 8. Tool Tray                               |                           |

F2.10: Detail A

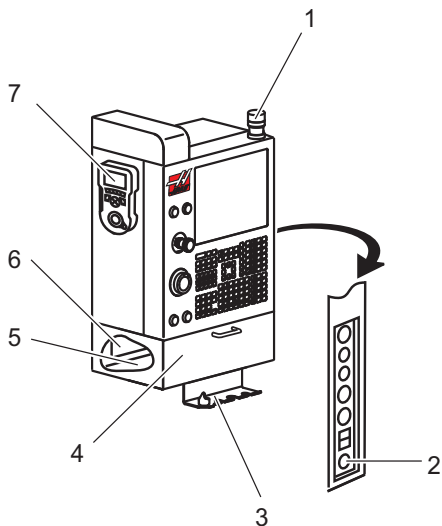

1. Work Beacon
2. Hold to Run (where equipped)
3. Vise Handle Holder
4. Storage Pull Down Access Door
5. Operator's Manual and Assembly Data (stored inside)
6. G & M Code Reference List (stored inside)
7. Remote Jog Handle

F2.11: Detail B

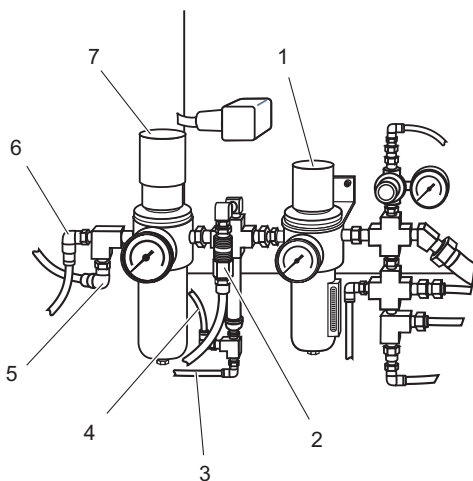

1. Air Filter/Regulator
2. Hose barb (Shop Air)
3. Air Gun 2 (Air Line)
4. Air Gun 1 (Air Line)
5. Air Blast Receiver
6. Pallet Clamp/Unclamp
7. High Flow Regulator

F2.12: Detail C

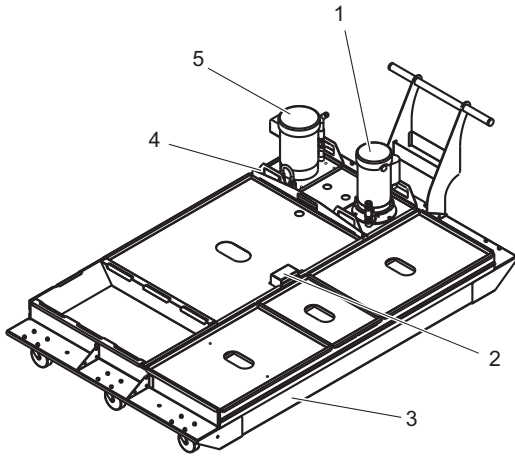

1. Standard Coolant Pump
2. Coolant Level Sensor
3. Chip Tray
4. Strainer
5. Through-Spindle Coolant Pump

F2.13: Detail D

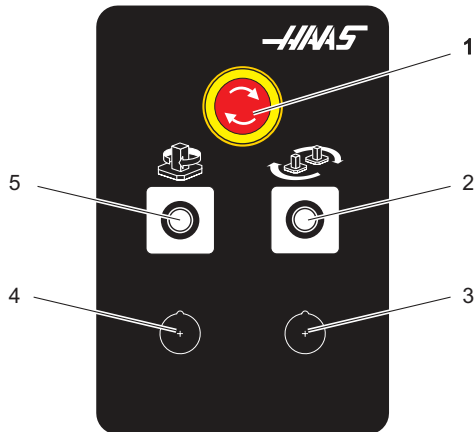

1. **[EMERGENCY STOP]** Button
2. **[PART READY]** Button
3. (Optional)
4. (Optional)
5. **[ROTARY INDEX]** Button

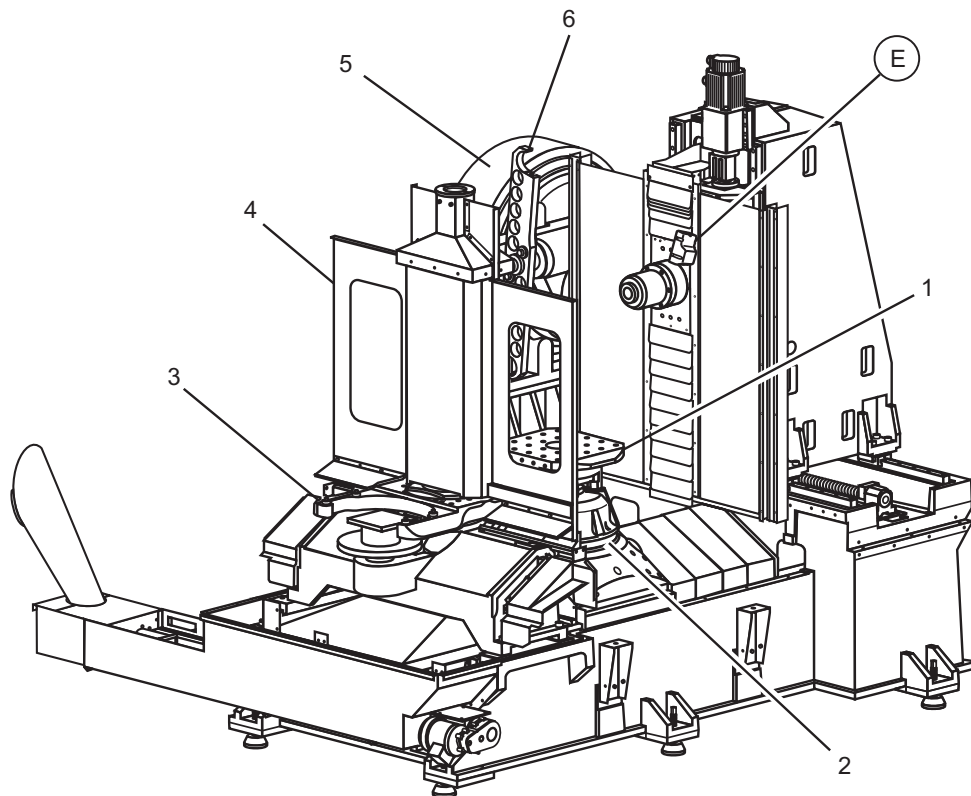

**F2.14:** Horizontal Mill Features (EC-400 covers removed)

1. Pallet (2)
2. Rotary
3. Pallet Support Arms (pallet removed)
4. Pallet Doors
5. SMTC
6. SMTC Arm

E EC-400 Coolant Nozzles

---

**F2.15:** Detail E

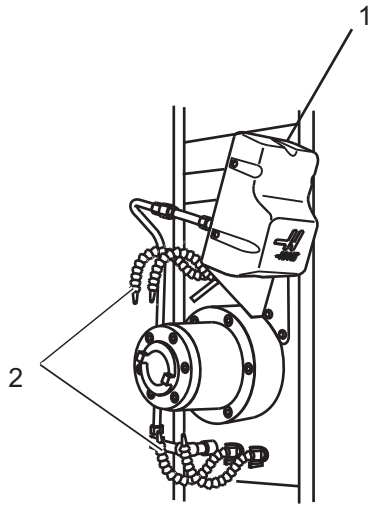

- 1. Optional P-Cool Assembly
- 2. Coolant Nozzle (4)

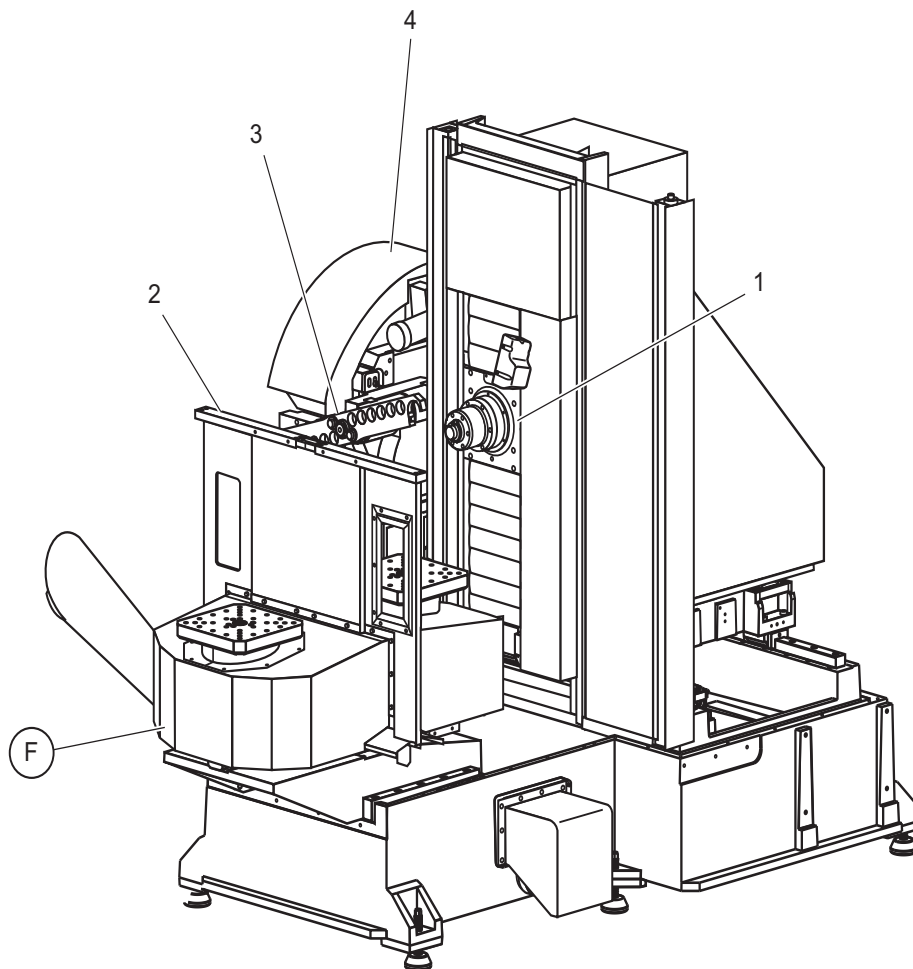
**F2.16:** Horizontal Mill Features (EC-300 covers removed)

1. Spindle
2. Pallet Doors
3. SMTC Arm
4. SMTC

F EC-300 Pallet Changer

---

**F2.17: Detail F**

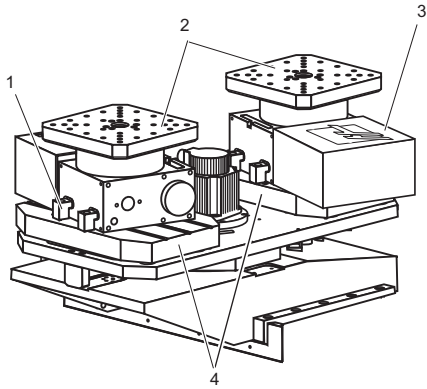

- 1. Toe Clamps (8)
- 2. Pallets (2)
- 3. HRT-210 Rotary (2)
- 4. Table (2)

View with Pallet Changer covers & rotating doors removed

**F2.18:** Horizontal Mill Features (EC-400 with Pallet Pool)

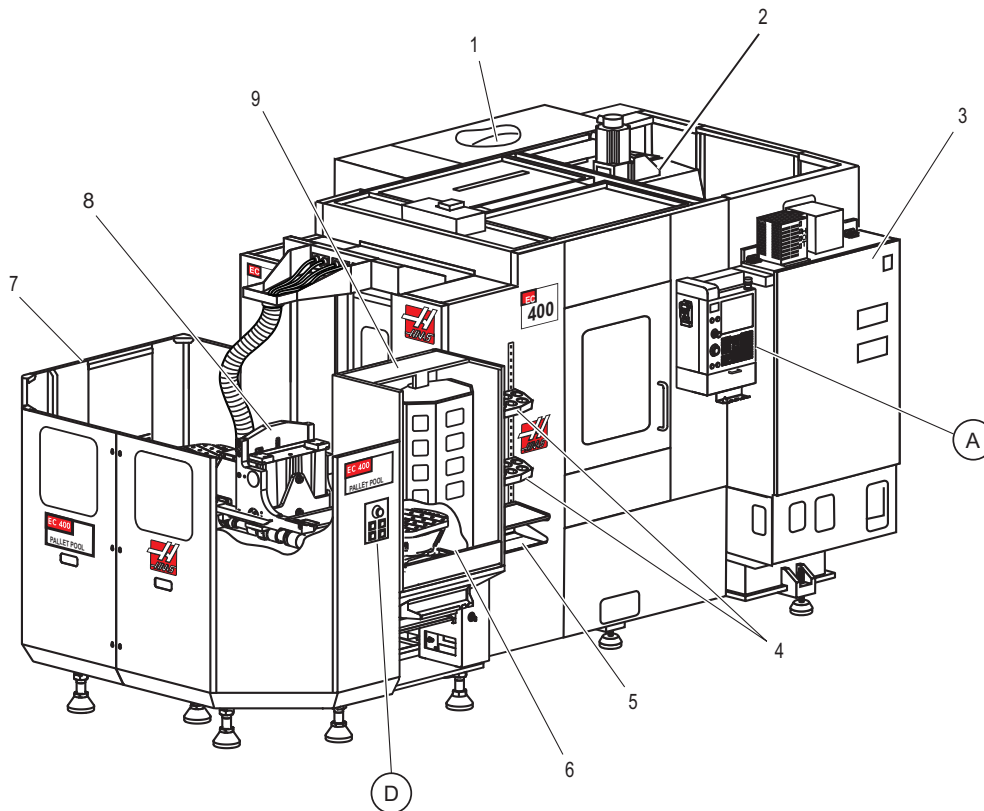

1. SMTC
2. X-axis and Y-axis column
3. Main Electrical Control Cabinet
4. Tool Crib
5. Front Table
6. Load Station
7. Pallet Pool
8. Pallet Pool Slider Assembly
9. Pallet Pool Load Station

A Control Pendant  
D Pallet Changer Controls

---

**F2.19:** Horizontal Mill Features (EC-550-630)

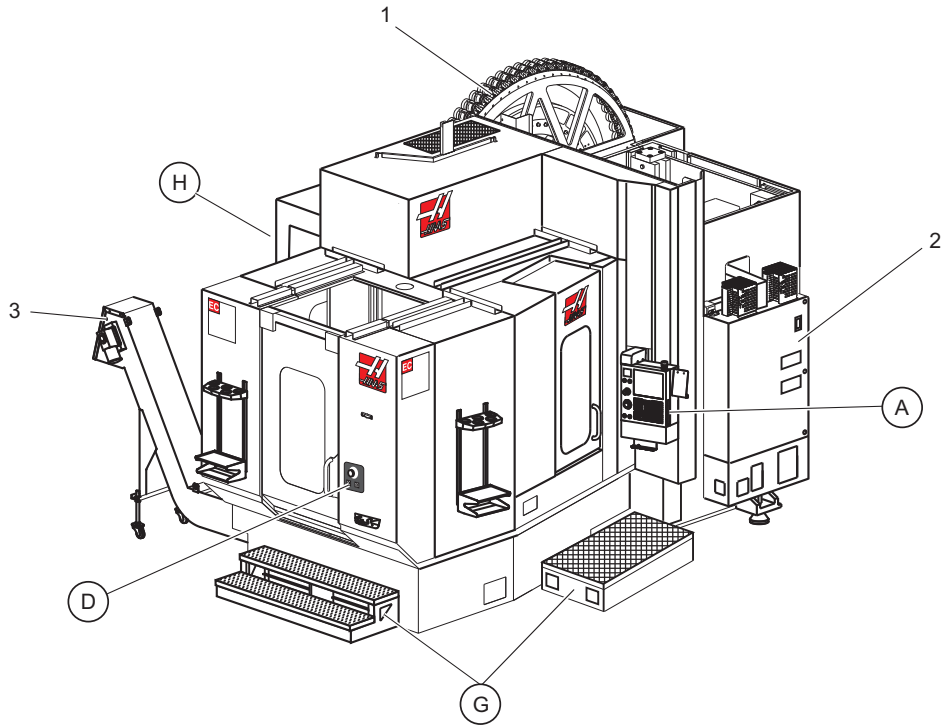

- 1. SMTC
- 2. Control Cabinet
- 3. Chip Conveyor

- A Control Pendant
- D Pallet Changer Controls
- G Stair/Step
- H Remote Tool Changer Controls

F2.20: Detail H

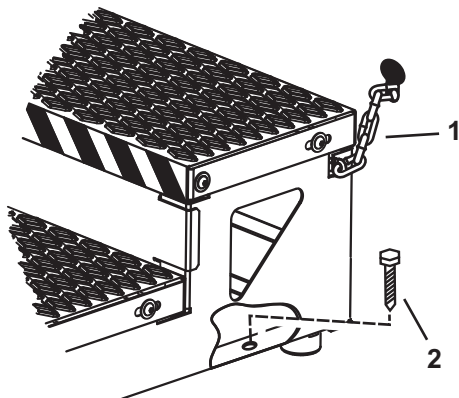

1. Chain to Enclosure
  2. Floor Anchor Bolt
- Secure the work platform with chains to the enclosure or bolts to the floor.

F2.21: Detail G

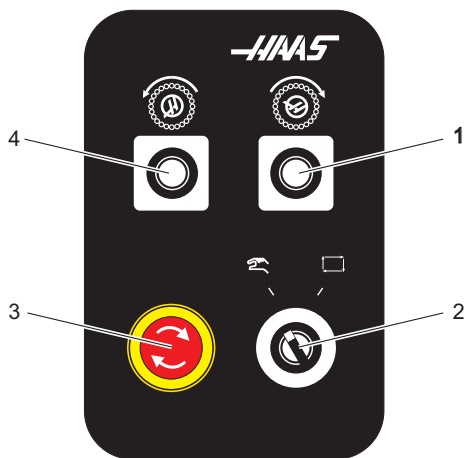

1. [ATC FWD]
2. [ATC REV]
3. Redundant [EMERGENCY STOP]
4. Manual/Automatic Tool Change Switch (enables/disables [1] and [4] controls)

**F2.22:** Horizontal Mill Features (EC-1600, 2000, and 3000)

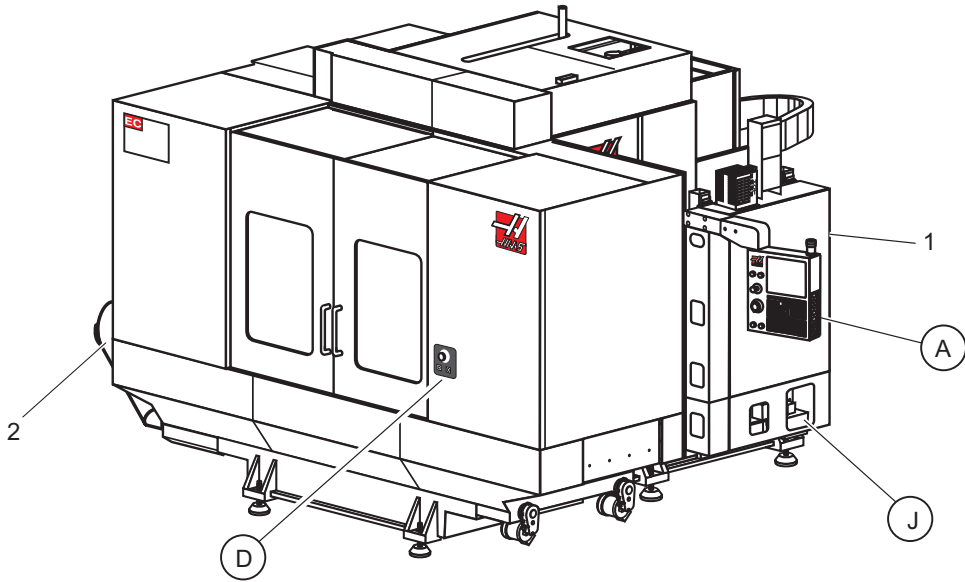

- 1. Control Cabinet
- 2. Chip Conveyor

- A Control Pendant
- D Pallet Changer Controls
- J Air/Lubrication Control Assembly

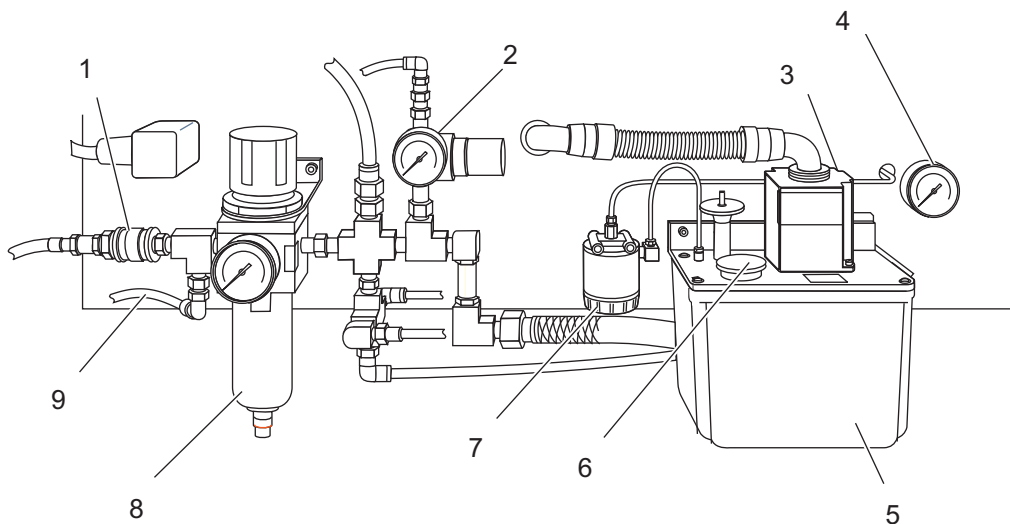

**F2.23:** Horizontal Mill Features (EC-1600 Air/Lubrication) Detail J

1. Hose Barb Shop Air
2. Air Pressure Gage
3. Oil Pump
4. Oil Pressure Gage
5. Oil Reservoir
6. Oil Fill
7. Oil Filter
8. Air Filter/Regulator
9. Air Nozzle Air Line

**F2.24:** Horizontal Mill Features (EC-1600 without covers)

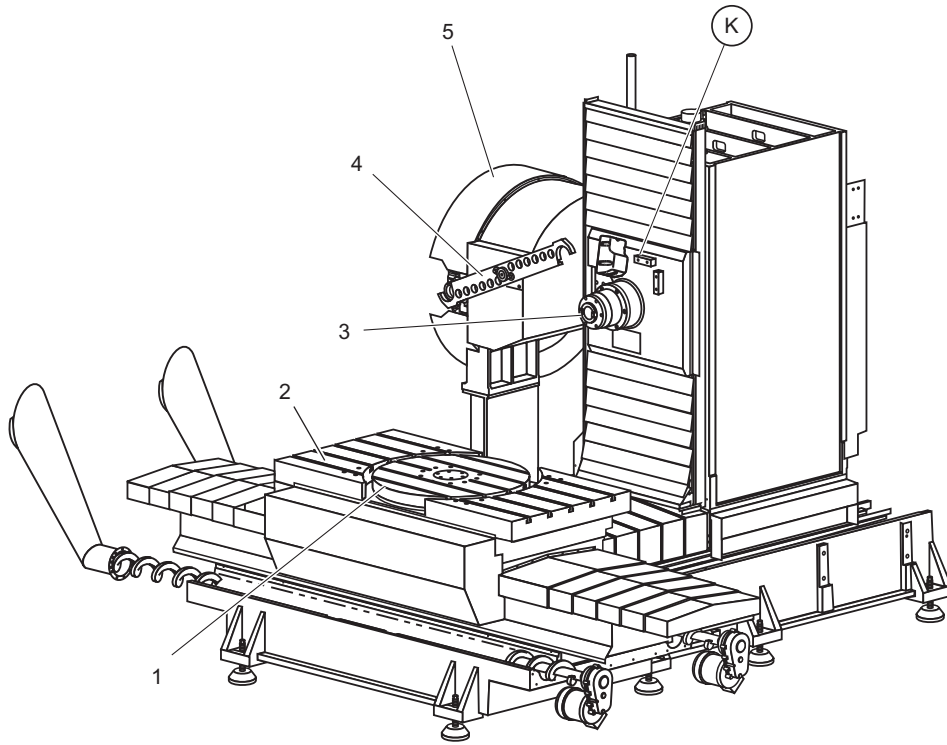

1. Rotary Table
2. X-Axis Table
3. Spindle
4. SMTC Arm
5. SMTC

K EC-1600 Coolant Nozzles

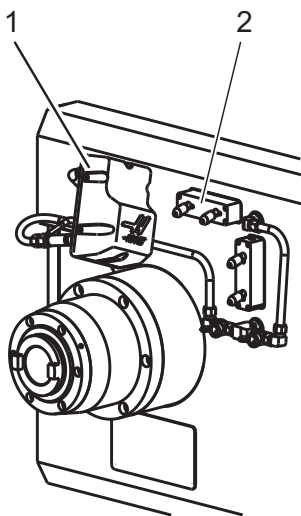
**F2.25:** Detail K

1. Optional Programmable Coolant Assembly
2. Coolant Nozzle (4)







## 2.3 Control Pendant

The control pendant is the main interface to your Haas machine. This is where you program and run your CNC machining projects. This control pendant orientation section describes the different pendant sections:

- Pendant front panel
- Pendant right side, top, and bottom
- Keyboard
- Screen displays

### 2.3.1 Pendant Front Panel







#### T2.1: Front Panel Controls

Name	Image	Function
<b>[POWER ON]</b>		Powers the machine on
<b>[POWER OFF]</b>		Powers the machine off.
<b>[EMERGENCY STOP]</b>		Press to stop all axis motion, disable servos, stop the spindle and tool changer, and turn off the coolant pump.
<b>[HANDLE JOG]</b>		This is used to jog axes (select in <b>[HANDLE JOG]</b> Mode). Also used to scroll through program code or menu items while editing.
<b>[CYCLE START]</b>		Starts a program. This button is also used to start a program simulation in graphics mode.
<b>[FEED HOLD]</b>		Stops all axis motion during a program. The spindle continues to run. Press <b>[CYCLE START]</b> to cancel.

## 2.3.2 Pendant Right Side, Top, and Bottom Panels

The following tables describe the right side, top, and bottom of the pendant.

### T2.2: Right Side Panel Controls

Name	Image	Function
USB		Plug compatible USB devices into this port. It has a removable dust cap.
Memory Lock		In the locked position, this keyswitch prevents alterations to programs, settings, parameters, offsets, and macro variables.
Setup Mode		In the locked position, this keyswitch enables all machine safety features. Unlock allows setup (refer to “Setup Mode” in the Safety section of this manual for details).
Second Home		Press to rapid all axes to the coordinates specified in G154 P20 (if equipped).
Servo Auto Door Override		Press this button to open or close the Servo Auto Door (if equipped).
Worklight		These buttons toggle the internal worklight and High Intensity Lighting (if equipped).

### T2.3: Pendant Top Panel

Beacon Light	
Provides quick visual confirmation of the machine’s current status. There are five different beacon states:	
Light Status	Meaning
Off	The machine is idle.

<b>Beacon Light</b>	
Solid Green	The machine is running.
Flashing Green	The machine is stopped, but is in a ready state. Operator input is required to continue.
Flashing Red	A fault has occurred, or the machine is in Emergency Stop.
Flashing Yellow	A tool has expired, and the tool life screen automatically displays.

**T2.4:** Pendant Bottom Panel

<b>Name</b>	<b>Function</b>
Keyboard Beeper	Located on the bottom of the control pendant. Turn the cover to adjust the volume.

### 2.3.3 Keyboard

Keyboard keys are grouped into the following functional areas:

1. Function
2. Cursor
3. Display
4. Mode
5. Numeric
6. Alpha
7. Jog
8. Overrides

Refer to Figure **F2.26** for the locations of these key groups on the keyboard.

**F2.26:** [1] Mill Keyboard: Function Keys, [2] Cursor Keys, [3] Display Keys, [4] Mode Keys, [5] Numeric Keys, [6] Alpha Keys, [7] Jog Keys, [8] Override Keys.

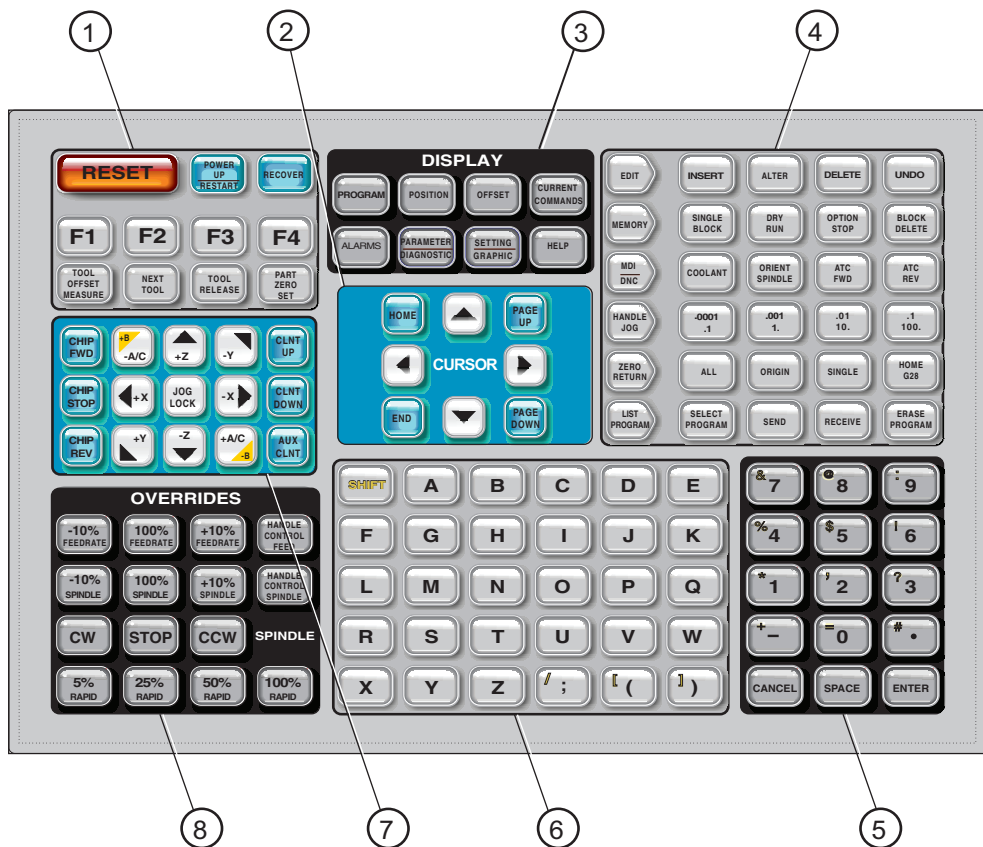

## Function Keys

Name	Key	Function
Reset	<b>[RESET]</b>	Clears alarms. Clears input text. Sets overrides to default values.
Power up/Restart	<b>[POWER UP/RESTART]</b>	Zero returns all axes and initializes the machine control.
Recover	<b>[RECOVER]</b>	Enters tool changer recovery mode.

Name	Key	Function
F1- F4	[F1 - F4]	These keys have different functions depending on the mode of operation.
Tool Offset Measure	[TOOL OFFSET MEASURE]	Records tool length offsets during part setup.
Next Tool	[NEXT TOOL]	Selects the next tool from the tool changer.
Tool Release	[TOOL RELEASE]	Releases the tool from the spindle when in MDI, ZERO RETURN, or HAND JOG mode.
Part Zero Set	[PART ZERO SET]	Records work coordinate offsets during part setup.

## Cursor Keys

Name	Key	Function
Home	[HOME]	Moves the cursor to the top-most item on the screen; in editing, this is the top left block of the program.
Cursor Arrows	[UP], [DOWN], [LEFT,] [RIGHT]	Moves one item, block, or field in the associated direction.   <b>NOTE:</b> <i>This manual refers to these keys by their spelled-out names.</i>
Page Up, Page Down	[PAGE UP] / [PAGE DOWN]	Used to change displays or move up/down one page when viewing a program.
End	[END]	Moves the cursor to the bottom-most item on the screen. In editing, this is the last block of the program.



## Display Keys

Display keys provide access to the machine displays, operational information, and help pages. They are often used to switch between active panes within a function mode. Some of these keys display additional screens if you press them more than once.

Name	Key	Function
Program	<b>[PROGRAM]</b>	Selects the active program pane in most modes. In MDI mode, press this key to access VQC and IPS/WIPS (if installed).
Position	<b>[POSITION]</b>	Selects the positions display.
Offsets	<b>[OFFSET]</b>	Press to toggle between the two offsets tables.
Current Commands	<b>[CURRENT COMMANDS]</b>	Displays menus for Maintenance, Tool Life, Tool Load, Advanced Tool Management (ATM), System Variables, Clock settings, and timer/counter settings.
Alarms / Messages	<b>[ALARMS]</b>	Displays the alarm viewer and message screens.
Parameter / Diagnostics	<b>[PARAMETER / DIAGNOSTIC]</b>	Displays parameters that define the machine's operation. Parameters are set at the factory and should not be modified except by authorized Haas personnel.
Settings / Graphics	<b>[SETTING / GRAPHIC]</b>	Displays and allows changing of user settings, and enables Graphics mode.
Help	<b>[HELP]</b>	Displays help information.

## Mode Keys

Mode keys change the operational state of the machine. All of the keys in the mode key's row perform functions related to that mode key. The current mode is always displayed in the top left of the screen, in Mode:Key display form.

### T2.5: EDIT:EDIT Mode Keys

Name	Key	Function
Edit	<b>[EDIT]</b>	Selects EDIT mode to edit programs in the control's memory.
Insert	<b>[INSERT]</b>	Enters text from the input line or the clipboard into the program at the cursor position.
Alter	<b>[ALTER]</b>	Replaces the highlighted command or text with text from the input line or the clipboard.
Delete	<b>[DELETE]</b>	Deletes the item that the cursor is on, or deletes a selected program block.
Undo	<b>[UNDO]</b>	Undoes up to the last 9 edit changes, and deselects a highlighted block.

### T2.6: OPERATION:MEM Mode Keys

Name	Key	Function
Memory	<b>[MEMORY]</b>	Selects memory mode. Programs are run from this mode, and the other keys in the MEM row control the ways in which the program is run.
Single Block	<b>[SINGLE BLOCK]</b>	Toggles single block on or off. When single block is on, the control runs only one program block each time you press <b>[CYCLE START]</b> .
Dry Run	<b>[DRY RUN]</b>	Checks actual machine movement without cutting a part.
Optional Stop	<b>[OPTION STOP]</b>	Toggles optional stop on or off. When optional stop is on, the machine will stop when it reaches M01 commands.
Block Delete	<b>[BLOCK DELETE]</b>	Toggles block delete on or off. Program ignores (does not execute) items with a slash ("/") when this option is enabled

**T2.7: EDIT:MDI/DNC Mode Keys**

Name	Key	Function
Manual Data Input / Direct Numeric Control	<b>[MDI/DNC]</b>	In MDI mode, you can run programs or blocks of code without saving them. DNC mode allows large programs to be "drip fed" into the control as they run.
Coolant	<b>[COOLANT]</b>	Turns the optional coolant on and off.
Orient Spindle	<b>[ORIENT SPINDLE]</b>	Rotates the spindle to a given position and then locks the spindle.
Automatic Tool Changer Forward / Reverse	<b>[ATC FWD] / [ATC REV]</b>	Rotates the tool turret to the next / previous tool.

**T2.8: SETUP: JOG Mode Keys**

Name	Key	Function
.0001/.1	<b>[.0001 / .1], [.001 / 1], [.01 / 10], [.1 / 100]</b>	Selects that amount to be jogged for each click of the jog handle. When the mill is in MM mode the first number is multiplied by ten when jogging the axis (e.g., .0001 becomes 0.001mm). The bottom number is used for dry run mode.

**T2.9: SETUP: ZERO Mode Keys**

Name	Key	Function
Zero Return	<b>[ZERO RETURN]</b>	Selects Zero Return mode, which displays axis location in four different categories, they are; Operator, Work G54, Machine, and Dist (distance) To Go. Press <b>[POSITION]</b> or <b>[PAGE UP]/[PAGE DOWN]</b> to switch between the categories.
All	<b>[ALL]</b>	Returns all axes to machine zero. This is similar to <b>[POWER UP/RESTART]</b> , except a tool change does not occur.
Origin	<b>[ORIGIN]</b>	Sets selected values to zero.

## Keyboard

Name	Key	Function
Single	[SINGLE]	Returns one axis to machine zero. Press the desired axis letter on the Alpha keyboard and then press [SINGLE].
Home G28	[HOME G28]	Returns all axes to zero in rapid motion. [HOME G28] will also home a single axis in the same manner as [SINGLE].   <b>CAUTION:</b> <i>All axes move immediately when you press this key. To prevent a crash, make sure the axis motion path is clear.</i>

### T2.10: EDIT:LIST Mode Keys

Name	Key	Function
List Programs	[LIST PROGRAM]	Accesses a tabbed menu to load and save programs.
Select Programs	[SELECT PROGRAM]	Makes the highlighted program the active program.
Send	[SEND]	Transmits programs out the optional RS-232 serial port.
Receive	[RECEIVE]	Receives programs from the optional RS-232 serial port.
Erase Program	[ERASE PROGRAM]	Deletes the selected program in List Program mode. Deletes the entire program in MDI mode.

## Numeric Keys

Use the numeric keys to type numbers, along with some special characters (printed in yellow on the main key). Press **[SHIFT]** to enter the special characters.

Name	Key	Function
Numbers	<b>[0]-[9]</b>	Types numbers.
Minus sign	<b>[-]</b>	Adds a minus (-) sign to the input line.
Decimal point	<b>[.]</b>	Adds a decimal point to the input line.
Cancel	<b>[CANCEL]</b>	Deletes the last character typed.
Space	<b>[SPACE]</b>	Adds a space to input.
Enter	<b>[ENTER]</b>	Answers prompts and writes input.
Special Characters	Press <b>[SHIFT]</b> , then a numeric key	Inserts the yellow character on the upper-left of the key. These characters are used for comments, macros, and certain special features.

## Alpha Keys

Use the alpha keys to type the letters of the alphabet, along with some special characters (printed in yellow on the main key). Press **[SHIFT]** to enter the special characters.

Name	Key	Function
Alphabet	<b>[A]-[Z]</b>	Uppercase letters are the default. Press <b>[SHIFT]</b> and a letter key for lowercase.
End-of-block (EOB)	<b>[;]</b>	This is the end-of-block character, which signifies the end of a program line.
Parentheses	<b>[(, )]</b>	Separate CNC program commands from user comments. They must always be entered as a pair.

<b>Name</b>	<b>Key</b>	<b>Function</b>
Shift	<b>[SHIFT]</b>	Accesses additional characters on the keyboard, or shifts to lower case alpha characters. The additional characters are seen in the upper left of some of the alpha and number keys.
Special Characters	Press <b>[SHIFT]</b> , then an alpha key	Inserts the yellow character on the upper-left of the key. These characters are used for comments, macros, and certain special features.

## **Jog Keys**

<b>Name</b>	<b>Key</b>	<b>Function</b>
Chip Forward	<b>[CHIP FWD]</b>	Starts the chip removal system in the forward direction (out of the machine).
Chip Auger Stop	<b>[CHIP STOP]</b>	Stops the chip removal system.
Chip Auger Reverse	<b>[CHIP REV]</b>	Starts the chip removal system in the "reverse" direction.
Axis Jog Keys	<b>[+X/-X, +Y/-Y, +Z/-Z, +A/C/-A/C AND +B/-B (SHIFT +A/C/-A/C)]</b>	Jog axes manually. Press and hold the axis button, or press and release to select an axis and then use the jog handle.
Jog Lock	<b>[JOG LOCK]</b>	Works with the axis jog keys. Press <b>[JOG LOCK]</b> , then an axis button, and the axis moves until you press <b>[JOG LOCK]</b> again.
Coolant Up	<b>[CLNT UP]</b>	Moves the optional Programmable Coolant (P-Cool) nozzle up.
Coolant Down	<b>[CLNT DOWN]</b>	Moves the optional P-Cool nozzle down.
Auxiliary Coolant	<b>[AUX CLNT]</b>	Press this key in MDI mode to toggle the Through-Spindle Coolant (TSC) system operation, if equipped.

## Override Keys

Name	Key	Function
-10% Feedrate	<b>[-10% FEEDRATE]</b>	Decreases the current feedrate by 10%.
100% Feedrate	<b>[100% FEEDRATE]</b>	Sets an overridden feedrate back to the programmed feed rate.
+10% Feedrate	<b>[+10% FEEDRATE]</b>	Increases the current feedrate by 10%.
Handle Control Feed Rate	<b>[HANDLE CONTROL FEED]</b>	Allows you to use the <b>[HANDLE JOG]</b> control to adjust the feedrate in 1% increments.
-10% Spindle	<b>[-10% SPINDLE]</b>	Decreases the current spindle speed by 10%.
100% Spindle	<b>[100% SPINDLE]</b>	Sets the overridden spindle speed back to the programmed speed.
+10% Spindle	<b>[+10% SPINDLE]</b>	Increases the current spindle speed by 10%.
Handle Control Spindle	<b>[HANDLE CONTROL SPINLE]</b>	Allows you to use the <b>[HANDLE JOG]</b> control to adjust the spindle speed in 1% increments.
Clockwise	<b>[CW]</b>	Starts the spindle in the clockwise direction.
Stop	<b>[STOP]</b>	Stops the spindle.
Counterclockwise	<b>[CCW]</b>	Starts the spindle in the counterclockwise direction.
Rapids	<b>[5% RAPID ]/ [25% RAPID ]/ [50% RAPID] / [100% RAPID]</b>	Limits machine rapids to the value on the key.

## Override Usage

Overrides allow you to temporarily adjust the speeds and feeds in your program. For example, you can slow down rapids while you prove out a program, or adjust the feedrate to experiment with its effect on part finish, etc.

You can use Settings 19, 20, and 21 to disable the feedrate, spindle, and rapid overrides, respectively.

**[FEED HOLD]** acts as an override, stopping rapid and feed moves when it is pressed. It also stops tool changes and part timers, but will not stop a threading cycle or a dwell timer.

Press **[CYCLE START]** to continue after a **[FEED HOLD]**. When the Setup Mode key is unlocked, the door switch on the enclosure also has a similar result but displays *Door Hold* when the door is opened. When the door is closed, the control is in Feed Hold and **[CYCLE START]** must be pressed to continue. Door Hold and **[FEED HOLD]** do not stop any auxiliary axes.

You can override the standard coolant setting by pressing **[COOLANT]**. The coolant pump remains either on or off until the next M-code or operator action (see Setting 32).

Use Settings 83, 87, and 88 to have M30 and M06 commands, or **[RESET]**, respectively, change overridden values back to their defaults.



## 2.3.4 Control Display

The control display is organized into panes that vary depending on the current mode and what display keys are used.

**F2.27:** Basic Control Display Layout

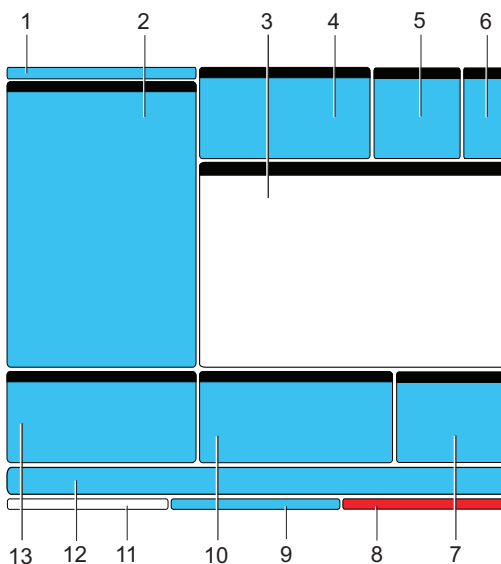

1. Mode and Active Display Bar
2. Program Display
3. Main Display
4. Active Codes
5. Active Tool
6. Coolant
7. Timers, Counters / Tool Management
8. Alarm Status
9. System Status Bar
10. Position Display / Axis Load Meters / Clipboard
11. Input Bar
12. Icon Bar
13. Spindle Status / Editor Help

The currently active pane has a white background. You can work with data in a pane only when that pane is active, and only one pane is active at any given time. For example, if you want to work with the **Program Tool Offsets** table, press **[OFFSET]** until the table displays with a white background. You can then make changes to the data. In most cases, you change the active pane with the display keys.

## Mode and Active Display Bar

Machine functions are organized into three modes: Setup, Edit, and Operation. Each mode provides all of the necessary information to perform tasks that fall under the mode, organized to fit in one screen. For example, Setup mode displays both the work and tool offset tables and position information. Edit mode provides two program editing panes and access to the optional Visual Quick Code system (VQC), Intuitive Programming System (IPS), and the optional Wireless Intuitive Probing System (WIPS) if installed. Operation mode includes MEM, the mode in which you run programs.

**F2.28:** The Mode and Display bar shows [1] the current mode and [2] the current display function.



**T2.11:** Mode, Key Access, and Bar Display

Mode	Mode Key	Bar Display	Function
Setup	[ZERO RETURN]	SETUP: ZERO	Provides all control features for machine setup.
	[HANDLE JOG]	SETUP: JOG	
Edit	[EDIT]	EDIT: EDIT	Provides all program editing, management, and transfer functions.
	[MDI/DNC]	EDIT: MDI	
	[LIST PROGRAM]	EDIT: LIST	
Operation	[MEMORY]	OPERATION: MEM	Provides all control features necessary to run a program.

## Offsets Display

There are two offset tables, the Program Tool Offsets table and the Active Work Offset table. Depending on the mode, these tables may appear in two separate display panes, or they may share a pane; press **[OFFSET]** to toggle between tables.

### T2.12: Offset Tables

Name	Function
Program Tool Offsets	This table displays tool numbers and tool length geometry.
Work Offsets	This table displays the values entered so that each tool knows where the part is located.

## Active Codes

### F2.29: Active Codes Display Example

ACTIVE CODES		
G00	RAPID MOTION	D00
G90	ABSOLUTE POSITION	H00
G40	CUTTER COMPENSATION CANCEL	M00
G80	CYCLE CANCEL	T0
G54	WORK OFFSET #54	

This display gives read-only, real-time information about the codes that are currently active in the program; specifically, the codes that define the current motion type (rapid vs linear feed vs circular feed), positioning system (absolute vs incremental), cutter compensation (left, right or off), active canned cycle, and work offset. This display also gives the active *Dnn*, *Hnn*, *Tnn*, and most recent *Mnnn* code.

## Active Tool

### F2.30: Active Tool Display Example



This display gives information on the current tool in the spindle, including the type of tool (if specified), the maximum tool load the tool has seen and the percentage of tool life remaining (if using Advanced Tool Management).

## Coolant Level Gauge

The coolant level is displayed in the upper-right of the screen in **OPERATION:MEM** mode. A vertical bar shows the coolant level. The vertical bar flashes when the coolant reaches a level that could cause coolant flow problems. This gauge is also displayed in **DIAGNOSTICS** mode under the **GAUGES** tab.

## Timers & Counters Display

The timer section of this display (located above the lower right of the screen) provides information about cycle times (This Cycle, Last Cycle, and Remaining).

The counter section also includes two M30 counters as well as a Loops Remaining display.

- M30 Counter #1: and M30 Counter #2: every time a program reaches an **M30** command, the counters increase by one. If Setting 118 is on, the counters also increment every time a program reaches an **M99** command.
- If you have macros, you can clear or change M30 Counter #1 with #3901 and M30 Counter #2 with #3902 (#3901=0).
- Refer to page **50** for information on how to reset the timers and counters.

- **Loops Remaining:** shows the number of subprogram loops remaining to complete the current cycle.

## Current Commands

This section briefly describes the different Current Commands pages and the types of data they provide. The information from most of these pages also appears in other modes.

To access this display, press [**CURRENT COMMANDS**], then press [**PAGE UP**] or [**PAGE DOWN**] to cycle through the pages.

**Operation Timers and Setup Display** - This page shows:

- The current date and time.
- The total power on time.
- Total cycle start time.
- Total feed time.
- Two M30 counters. Each time the a program reaches an **M30** command, both of these counters increment by one.
- Two macro variable displays.

These timers and counters appear in the lower right section of the display in the **OPERATION:MEM** and **SETUP:ZERO** modes.

**Macro Variables Display** -This page shows a list of the macro variables and their current values. The control updates these variables as programs run. You can also modify the variables in this display; Refer to the Macros section, starting on page **178** for more information.

**Active Codes** - This page lists the currently active program codes. A smaller version of this display is included on the **OPERATION:MEM** mode screen.

**Positions** - This page shows a larger view of the current machine positions, with all of the position reference points (operator, machine, work, distance to go) on the same screen. Refer to page **49** for more information on position displays.



**NOTE:**

*You can handle jog the machine axes from this screen if the control is in **SETUP:JOG** mode.*

**Tool Life Display** - This page shows information that the control uses to predict tool life.

**Tool Load Monitor and Display** - On this page, you can enter the maximum tool load percentage that is expected for each tool.

**Maintenance** - On this page, you can activate and deactivate a series of maintenance checks.

**Advanced Tool Management** - This feature allows you to create and manage tool groups. For more information, refer to the Advanced Tool Management section in the Operation chapter of this manual.

### Timer and Counter Reset

To reset the timers and counters on the **CURRENT COMMANDS TIMERS AND COUNTERS** page:

1. Press the cursor arrow keys to highlight the name of the timer or counter that you want to reset.
2. Press **[ORIGIN]** to reset the timer or counter.



**TIP:**

*You can reset the M30 counters independently to track finished parts in two different ways; for example, parts finished in a shift and total parts finished.*

### Date and Time Adjustment

To adjust the Date and Time:

1. Press **[CURRENT COMMANDS]**.
2. Press **[PAGE UP]** or **[PAGE DOWN]** until you see the **DATE AND TIME** screen.
3. Press **[EMERGENCY STOP]**.
4. Type the current date (in MM-DD-YYYY format) or current time (in HH:MM:SS format).



**NOTE:**

*You must include the dash (-) or colon (:) when you enter a new date or time.*

5. Press **[ENTER]**. Make sure the new date or time is correct. Repeat step 4 if it is not correct.
6. Reset **[EMERGENCY STOP]** and clear Alarm.

## Alarms and Messages

Press **[ALARMS]** to access the Alarms and Messages displays. Press **[ALARMS]** again to toggle between the ALARMS and MESSAGES displays.

## System Status Bar

The System Status Bar is the read-only section of the screen located in the bottom, center. It displays messages for the user about actions they have taken.

## Position Display

The Position display usually appears near the lower center of the screen. It shows the current axis position relative to four reference points (Operator, Work, Machine and Distance-to-go). In **SETUP: JOG** mode, this display shows all of the relative positions at the same time. In other modes, press **[POSITION]** to cycle through the different reference points.

### T2.13: Axis Position Reference Points

Coordinate Display	Function
<b>OPERATOR</b>	This position shows the distance you have jogged the axes. This does not necessarily represent the actual distance the axis is from machine zero, except when the machine is first powered on. Type the axis letter and press <b>[ORIGIN]</b> to zero the position value for that axis.
<b>WORK (G 54)</b>	This displays the axis positions relative to part zero. On power-up, this position uses work offset G54 automatically. It will then display the axis positions relative to the most recently-used work offset.
<b>MACHINE</b>	This displays the axis positions relative to machine zero.
<b>DIST TO GO</b>	This displays the distance remaining before the axes reach their commanded position. When in <b>SETUP: JOG</b> mode, you can use this position display to show a distance moved. Change modes (MEM, MDI) and then switch back to <b>SETUP: JOG</b> mode to zero this value.

## Position Display Axis Selection

Use this function to change the axis positions that show in the display.

1. With a position display active, press **[F2]**. The **Axis Selection** pop-up menu appears.

**F2.31:** The Axis Selection Pop-up Menu

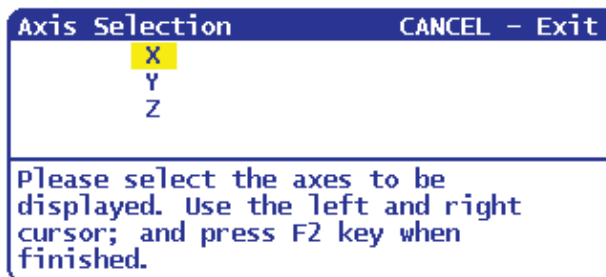

2. Press the **[LEFT]** and **[RIGHT]** cursor arrow keys to highlight an axis letter.
3. Press **[ENTER]** to place a check mark next to the highlighted axis letter. This mark means that you want to include that axis letter in the position display.

**F2.32:** The X and Y Axes Selected in the Axis Selection Menu

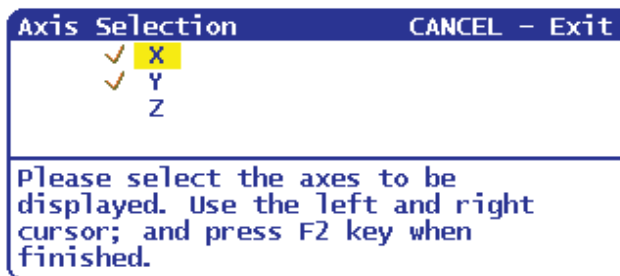

4. Repeat steps 2 and 3 until you have selected all of the axes you want to display.
5. Press **[F2]**. The position display updates with your selected axes.



**F2.33:** The Updated Position Display

POSITION: OPERATOR			
	(IN)		LOAD
X	0.0000	<input type="text"/>	0%
Y	0.0000	<input type="text"/>	0%
Press POSIT to cycle Coordinate displays.			



## Input Bar

The Input Bar is the data entry section located in the bottom, left corner of the screen. This is where your input appears as you type it.

## Icon Bar

The Icon Bar is divided into 18 image display fields. A machine condition icon will appear in one or more of the fields.



**T2.14:** Field 1

Name	Icon	Meaning
SETUP LOCKED		Setup mode is locked. Refer to page 4 for more information.
SETUP UNLOCKED		Setup mode is unlocked. Refer to page 4 for more information.



## Control Display

---







### T2.15: Field 2

Name	Icon	Meaning
DOOR HOLD		Machine motion has stopped because of door rules.
RUNNING		The machine is running a program.





### T2.16: Field 3

Name	Icon	Meaning
RESTART		The control is scanning the program before a program restart. Refer to Setting 36 on page 349.
SINGB STOP		<b>SINGLE BLOCK</b> mode is active, and the control is waiting for a command to continue. Refer to page 38 for more information.
DNC RS232		<b>DNC RS-232</b> mode is active.



## T2.17: Field 4

Name	Icon	Meaning
FEED HOLD		The machine is in feed hold. Axis motion has stopped, but the spindle continues to turn.
FEED		The machine is executing a cutting move.
M FIN		The control is waiting for M-finish signal from an optional user interface (M121-M128).
M FIN*		The control is waiting for the M-finish signal from an optional user interface (M121-M128) to stop.
RAPID		The machine is executing a non-cutting axis move at the fastest possible rate.
DWELL		The machine is executing a dwell (G04) command.



## T2.18: Field 5

Name	Icon	Meaning
JOG LOCK ON		Jog lock is active. If you press an axis key, that axis moves at the current jog rate until you press <b>[JOG LOCK]</b> again.
JOGGING, YZ MANUAL JOG, VECTOR JOG		An axis is jogging at the current jog rate.
REMOTE JOG		The optional remote jog handle is active.
RESTRICTED ZONE		A current axis position is in the restricted zone. (Lathe only)





## T2.19: Field 6

Name	Icon	Meaning
G14		Mirroring mode is active.
X MIRROR, Y MIRROR, XY MIRROR		Mirroring mode is active in the positive direction.
X -MIRROR, Y -MIRROR, XY -MIRROR		Mirroring mode is active in the negative direction.



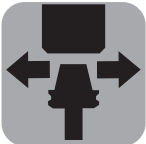

## T2.20: Field 7

Name	Icon	Meaning
A/B/C/AB/CB/CA AXIS UNCLAMPED		A rotary axis, or a combination of rotary axes, is unclamped.
SPINDLE BRAKE ON		The lathe spindle brake is on.

T2.21: Field 8

Name	Icon	Meaning
TOOL UNCLAMPED		<p>The tool in the spindle is unclamped. (Mill only)</p>
CHECK LUBE, LOW SS LUBE		<p>The control has detected a low lubrication state.</p>
LOW AIR PRESSURE		<p>Air pressure to the machine is insufficient.</p>
LOW ROTARY BRAKE OIL		<p>The rotary brake oil level is low.</p>
MAINTENANCE DUE		<p>A maintenance procedure is due, based on information in the <b>MAINTENANCE</b> page. Refer to page <b>49</b> for more information.</p>

## T2.22: Field 9

Name	Icon	Meaning
EMERGENCY STOP, PENDANT		<b>[EMERGENCY STOP]</b> on the pendant has been pressed. This icon disappears when <b>[EMERGENCY STOP]</b> is released.
Mill: EMERGENCY STOP, PALLET Lathe: EMERGENCY STOP, BARFEED		<b>[EMERGENCY STOP]</b> on the pallet changer (mill) or the bar feeder (lathe) has been pressed. This icon disappears when <b>[EMERGENCY STOP]</b> is released.
Mill: EMERGENCY STOP, TC CAGE Lathe: EMERGENCY STOP, AUXILIARY 1		<b>[EMERGENCY STOP]</b> on the tool changer cage (mill) or auxiliary device (lathe) has been pressed. This icon disappears when <b>[EMERGENCY STOP]</b> is released..
Mill: EMERGENCY STOP, AUXILIARY Lathe: EMERGENCY STOP, AUXILIARY 2		<b>[EMERGENCY STOP]</b> on an auxiliary device has been pressed. This icon disappears when <b>[EMERGENCY STOP]</b> is released.

## T2.23: Field 10

Name	Icon	Meaning
SINGLE BLK		<b>SINGLE BLOCK</b> mode is active. Refer to page 38 for more information.

T2.24: Field 11

Name	Icon	Meaning
DRY RUN	 A grey square icon with rounded corners containing a white silhouette of a person running to the right, with three horizontal lines behind their legs to indicate motion.	<b>DRY RUN</b> mode is active. Refer to page <b>107</b> for more information.

T2.25: Field 12



Name	Icon	Meaning
OPTIONAL STOP	 A grey square icon with rounded corners containing a white staircase graphic with a red circle at the bottom right end.	<b>OPTIONAL STOP</b> is active. The control stops the program at each M01 command.

T2.26: Field 13





Name	Icon	Meaning
BLOCK DELETE	 A grey square icon with rounded corners containing a white staircase graphic with a large black 'X' over it.	<b>BLOCK DELETE</b> is active. The control skips program blocks that begin with a slash (/).

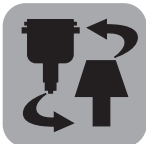

## T2.27: Field 14

Name	Icon	Meaning
CAGE OPEN		The side-mount tool changer door is open.
TC MANUAL CCW		The side-mount tool changer carousel is rotating counter-clockwise as commanded by a manual carousel rotation button.
TC MANUAL CW		The side-mount tool changer carousel is rotating clockwise as commanded by a manual carousel rotation button.
TC MOTION		A tool change is in progress.



T2.28: Field 15

Name	Icon	Meaning
PROBE DOWN		The probe arm is down for a probing operation.
PART CATCHER ON		The parts catcher is activated. (Lathe only)
TS PART HOLDING		The tailstock is engaged with the part. (Lathe only)
TS PART NOT HOLDING		The tailstock is not engaged with the part. (Lathe only)
CHUCK CLAMPING		The collet closer-type chuck is clamping. (Lathe only)



**T2.29:** Field 16

Name	Icon	Meaning
TOOL CHANGE		A tool change is in progress.

**T2.30:** Field 17

Name	Icon	Meaning
AIR BLAST ON		The Auto Air Gun (mill) or Auto Jet Air Blast (lathe) is active.
CONVEYOR FORWARD		The conveyor is active and currently moving forward.
CONVEYOR REVERSE		The conveyor is active and currently moving in reverse.

T2.31: Field 18

Name	Icon	Meaning
COOLANT ON		The main coolant system is active.
THROUGH-SPINDLE COOLANT (TSC) ON		The Through-Spindle Coolant (TSC) system is active. (Mill only)
HIGH PRESSURE COOLANT		The High-Pressure Coolant system is active. (Lathe only)

## Main Spindle Display

F2.34: Main Spindle (Speed and Feed Status) Display

MAIN SPINDLE		
	<b>SPINDLE SPEED:</b>	<b>0 RPM</b>
<b>OVERRIDES</b>	<b>SPINDLE LOAD:</b>	<b>0.0 KW</b>
<b>FEED: 100%</b>	<b>SURFACE SPEED:</b>	<b>0 FPM</b>
<b>SPINDLE: 100%</b>	<b>CHIP LOAD:</b>	<b>0.00000</b>
<b>RAPID: 100%</b>	<b>FEED RATE:</b>	<b>0.0000</b>
<b>SPINDLE LOAD(%)</b>	<input type="text" value=""/>	<b>0%</b>

This first column of this display gives you information about spindle status and the current override values for spindle, feed, and rapids.

The second column displays actual motor load in kW. This value reflects the actual spindle power to the tool. It also displays current programmed and actual spindle speed as well as programmed and actual feed rate.

The bar-graph spindle load meter indicates the current spindle load as a percentage of motor capacity.

### 2.3.5 Screen Capture

The control can capture and save an image of the current screen to an attached USB device or the hard drive. If no USB device is connected and the machine does not have a hard drive, no image will be saved.

1. If you want to save the screen capture under a particular filename, type it first. The control adds the \*.bmp file extension automatically.



**NOTE:**

*If you do not specify a filename, the control will use the default filename `snapshot.bmp`. This will overwrite any screen capture taken previously with the default name. Be sure to specify a filename each time if you want to save a series of screen captures.*

2. Press **[SHIFT]**.
3. Press **[F1]**.

The screen capture is saved to your USB device or the machine's hard drive, and the control displays the message *Snapshot saved to HDD/USB* when the process is finished.

## 2.4 Tabbed Menu Basic Navigation

Tabbed menus are used in several control functions, such as Parameters, Settings, Help, List Programs, and IPS. To navigate these menus:

1. Use the **[LEFT]** and **[RIGHT]** cursor arrows to select a tab.
2. Press **[ENTER]** to open the tab.
3. If the selected tab contains sub-tabs, use the cursor arrows, then press **[ENTER]** to select the sub-tab you want. Press **[ENTER]** again to open the sub-tab.

**NOTE:**

*In the tabbed menus for parameters and settings, and in the **ALARM VIEWER** section of the **Alarm / Messages** display, you can type the number of a parameter, setting, or alarm that you want to view, then press the **[UP]** or **[DOWN]** cursor arrow to view it.*

4. Press **[CANCEL]** if you want to close a sub-tab and return to the higher tab level.

## 2.5 Help

Use the help function when you need information about machine functions, commands, or programming. The content of this manual is also available on the control.

When you press **[HELP]**, a pop-up menu appears with options for different help information. If you want to directly access the help tabbed menu, press **[HELP]** again. Refer to page **67** for information on that menu. Press **[HELP]** again to exit the help function.

### F2.35: The Pop-up Help Menu

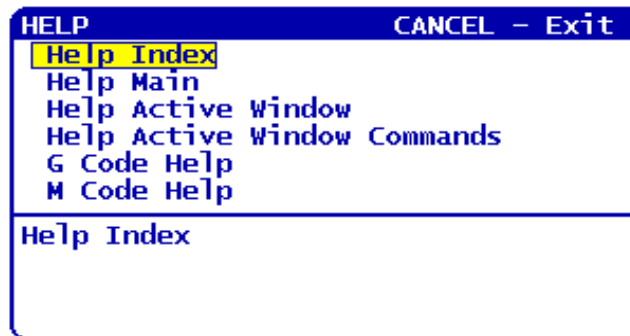

Use the **[UP]** and **[DOWN]** cursor arrow keys to highlight an option, then press **[ENTER]** to select it. The options available from this menu are:

- **Help Index** - Gives a list of available help topics that you can choose from. For more information, refer to the “Help Index” section on page **68**.
- **Help Main** - Gives the table of contents for the Operator’s Manual on the control. Use the **[UP]** and **[DOWN]** cursor arrow keys to select a topic and press **[ENTER]** to see that topic’s contents.
- **Help Active Window** - Gives the help system topic that relates to the currently active window.
- **Help Active Window Commands** - Gives a list of the available commands for the active window. You can use the hot keys listed in parentheses, or you can select a command from the list.

- **G Code Help** - Gives a list of G-codes you can select from in the same manner as the **Help Main** option for more information.
- **M Code Help** - Gives a list of M-codes that you can select from in the same manner as the **Help Main** option for more information.

## 2.5.1 The Help Tabbed Menu

To access the help tabbed menu, press **HELP** until you see the **Operator's Manual Table of Contents**. You can then navigate the Operator's Manual content that is saved on the control.

You can access other help functions from the tabbed menu; press **[CANCEL]** to close the **Operator's Manual Table of Contents** tab and access the rest of the menu. For information on navigating tabbed menus, refer to page **65**.

These are the available tabs. They are described in more detail in the sections that follow.

- **Search** - Allows you to enter a keyword to find in the Operator's Manual content that is saved on the control.
- **Help Index** - Gives a list of available help topics that you can choose from. This is the same as the **Help Index** menu option described on page **66**.
- **Drill Table** - Gives a reference table of drill and tap sizes with decimal equivalents.
- **Calculator** - This sub-tabbed menu provides options for several geometric and trigonometric calculators. Refer to the "Calculator Tab" section, starting on page **68** for more information.

## 2.5.2 Search Tab

Use the Search tab to look for help content by keyword.

1. Press **[F1]** to search manual contents, or press **[CANCEL]** to exit the Help tab and select the Search tab.
2. Type your search term in the text field.
3. Press **[F1]** to execute the search.
4. The results page displays topics that contain your search term; highlight a topic and press **[ENTER]** to view.

## 2.5.3 Help Index

This option provides a list of manual topics that link to the information in the on-screen manual. Use the cursor arrows to highlight a topic of interest, and then press **[ENTER]** to access that section of the manual.

## 2.5.4 Drill Table Tab

Displays a drill size table featuring decimal equivalents and tap sizes.

1. Select the Drill Table tab. Press **[ENTER]**.
2. Use **[PAGE UP]** or **[PAGE DOWN]** and the **[UP]** and **[DOWN]** cursor arrows to read the table.

## 2.5.5 Calculator Tab

The **CALCULATOR** tab has sub-tabs for different calculator functions. Highlight the sub-tab you want and press **[ENTER]**.

### Calculator

All of the Calculator sub-tabs perform simple add, subtract, multiply, and divide operations. When one of the sub-tabs is selected, a calculator window appears with the possible operations (LOAD, +, -, \*, and /).

1. **LOAD** and the calculator window are initially highlighted. The other options can be selected with Left/Right cursors. Numbers are entered by typing them and pressing **[ENTER]**. When a number is entered and **LOAD** and the calculator window are highlighted, that number is entered into the calculator window.
2. When a number is entered when one of the other functions (+, -, \*, /) is selected, that calculation will be performed with the number just entered and any number that was already in the calculator window (like RPN).
3. The calculator will also accept a mathematical expression such as  $23*4-5.2+6/2$ , evaluating it (doing multiplication and division first) and placing the result, 89.8 in this case, in the window. No exponents are allowed.



**NOTE:**

*Data cannot be entered in any field where the label is highlighted. Clear data in other fields (by pressing **[F1]** or **[ENTER]**) until the label is no longer highlighted in order to change the field directly.*

4. **Function Keys:** The function keys can be used to copy and paste the calculated results into a section of a program or into another area of the Calculator feature.
5. **[F3]:** In EDIT and MDI modes, **[F3]** will copy the highlighted triangle/circular milling/tapping value into the data entry line at the bottom of the screen. This is useful when the calculated solution will be used in a program.



6. In the Calculator function, pressing **[F3]** copies the value in the calculator window to the highlighted data entry for Trig, Circular or Milling/Tapping calculations.
7. **[F4]**: In the Calculator function, this button uses the highlighted Trig, Circular or Milling/Tapping data value to load, add, subtract, multiply, or divide with the calculator.

## Triangle Sub-tab

The triangle calculator page takes a few triangle measurements and solves for the rest of the values. For inputs that have more than one solution, entering the last data value a second time will cause the next possible solution to be displayed.

1. Use the **[UP]** and **[DOWN]** cursor arrows to select the field for the value to be entered.
2. Type a value, then press **[ENTER]**.
3. Enter the known lengths and angles of a triangle.

When enough data has been entered, the control solves the triangle and displays the results.

### F2.36: Calculator Triangle Example

HELP SEARCH DRILL TABLE CALCULATOR

CALCULATOR

0.00000000

LOAD + - \* /

ANGLE 1	40.000
ANGLE 2	72.000
ANGLE 3	68.000
SIDE 1	10.0000
SIDE 2	14.7958
SIDE 3	14.4244

ANGLE 1 ANGLE 3 ANGLE 2

SIDE 2 SIDE 1

SIDE 3

F3 copies calculator value to highlighted field in this or other calculator screens. F3 also copies calculator value to the data entry line of edit screens. F4 copies highlighted data to the calculator field.

TRIANGLE CIRCLE MILLING AND TAPPING CIRCLE-LINE-TANGENT CIRCLE-CIRCLE-TANGENT

## Circle Sub-tab

This calculator page will help solve a circle problem.

1. Use the **[UP]** and **[DOWN]** cursor arrows to select the field for the value to be entered.
2. Type the center, radius, angles, start and end points. Press **[ENTER]** after each entry.

When enough data has been entered, the control solves for the circular motion and displays the rest of the values. Press **[ENTER]** in the **DIRECTION** field to change **CW/CCW**. The control also lists alternate formats that such a move could be programmed with a **G02** or **G03**. Select the format you want and press **[F3]** to import the highlighted line into the program being edited.

**F2.37:** Calculator Circle Example

HELP SEARCH DRILL TABLE CALCULATOR

CALCULATOR

0.000000000

LOAD + - \* /

CENTER X	13.0000
CENTER Y	20.0000
START X	4.0000
START Y	10.0000
END X	7.0000
END Y	32.0416
RADIUS	13.4536
ANGLE	111.527
DIRECTION	CW

E

S

```
G90 G2 X7. Y32.0416 I9. J10.;
G90 G2 X7. Y32.0416 R13.4536;
G91 G2 X3. Y22.0416 I9. J10.;
G91 G2 X3. Y22.0416 R13.4536;
```

TRIANGL CIRCLE MILLING AND TAPPING CIRCLE-LINE-TANGENT CIRCLE-CIRCLE-TANGENT

## Milling and Tapping Sub-tab

This calculator helps you determine the correct speeds and feeds for your application. Enter all of the available information about your tooling, material, and planned program, and the calculator fills in recommended feedrates when it has enough information.

2

### F2.38: Calculator Milling and Tapping Example

HELP	SEARCH	DRILL TABLE	CALCULATOR
<p><b>CALCULATOR</b></p> <p>0.00000000</p> <p>LOAD + - * /</p>			
<p><b>MILLING</b></p> <p>CUTTER DIA * .*** IN</p> <p>SURFACE SPEED * .*** FT/MIN</p> <p>RPM * .***</p> <p>FLUTES * .***</p> <p>FEED * .*** IN/MIN</p> <p>CHIP LOAD * .*** IN/TTH</p> <p>MATERIAL PRESS &lt; or &gt; FOR MATERIALS</p>			
<p><b>TAPPING</b></p> <p>THREADS * .*** /IN</p> <p>RPM * .***</p> <p>FEED * .*** IN/MIN</p>			
TRIANG	CIRCL	MILLING AND TAPPING	CIRCLE-LINE-TANGENT CIRCLE-CIRCLE-TANGENT

## Circle-Line-Tangent Sub-tab

This feature provides the ability to determine points of intersection where a circle and a line meet as tangent.

1. Use the **[UP]** and **[DOWN]** cursor arrows to highlight the data field for the value you want to enter.
2. Type the value and press **[ENTER]**.
3. Enter two points, A and B, on a line and a third point, C, away from that line.

The control calculates the point of intersection. The point is where a normal line from point C will intersect with the line AB, as well as the perpendicular distance to that line.

### F2.39: Calculator Circle-Line-Tangent Example

The screenshot displays the 'CALCULATOR' interface for the 'CIRCLE LINE TANGENT' function. The interface includes a menu bar with 'HELP', 'SEARCH', 'DRILL TABLE', and 'CALCULATOR'. The main area is divided into a data entry section on the left and a diagram on the right. The data entry section shows 'CIRCLE LINE TANGENT' with fields for 'POINT A X', 'POINT A Y', 'POINT B X', 'POINT B Y', 'POINT C X', and 'POINT C Y'. Below these are fields for 'RADIUS', 'TANGENT X', and 'TANGENT Y'. The diagram shows a circle with center 'C' and a line segment 'AB' tangent to the circle at a point. The calculator interface also shows a numeric keypad with '0.000000000' and 'LOAD + - \* /' buttons.

CIRCLE LINE TANGENT	
POINT A X	5.0000
POINT A Y	3.0000
POINT B X	1.0000
POINT B Y	4.0000
POINT C X	0.0000
POINT C Y	0.0000
RADIUS	4.1231
TANGENT X	1.0000
TANGENT Y	4.0000

## Circle-Circle-Tangent Sub-tab

This feature determines points of intersection between two circles or points. You provide the location of two circles and their radii. The control calculates the intersection points that are formed by lines tangent to both circles.

**NOTE:**

*For every input condition (two disjointed circles), there are up to eight intersection points. Four points are from drawing straight tangents and four points by forming cross tangents.*

1. Use the UP and DOWN cursor arrows to highlight the data field for the value you want to enter.
2. Type the value and press **[ENTER]**.

After you enter the required values, the control displays the tangent coordinates and associated straight type diagram.

3. Press **[F1]** to toggle between straight and cross tangent results.
4. Press **[F]** and the control prompts for the From and To points (A, B, C, etc.) that specify a segment of the diagram. If the segment is an arc, the control will also prompt for **[C]** or **[W]** (CW or CCW). To quickly change segment selection, press **[T]** to make the previous To point become the new From point and the control prompts for a new To point.

The Input Bar displays the G code for the segment. Solution is in G90 mode. Press M to toggle to G91 mode.

5. Press **[MDI DNC]** or **[EDIT]** and press **[INSERT]** to enter the G-code from the Input Bar.

F2.40: Calculator Circle-Circle-Tangent Type: Straight Example

HELP SEARCH DRILL TABLE CALCULATOR

CALCULATOR CIRCLE-CIRCLE TANGENT

0.000000000  
LOAD + - \* /

CIRCLE1 X	5.0000
CIRCLE1 Y	3.0000
RADIUS 1	2.0000
CIRCLE2 X	0.0000
CIRCLE2 Y	0.0000
RADIUS 2	1.0000

TANGENT A X	3.6921
Y	4.5131
TANGENT B X	5.7196
Y	1.1340
TANGENT C X	-0.6539
Y	0.7566
TANGENT D X	0.3598
Y	-0.9330

TYPE: STRAIGHT

Use F and T to form G-code. Press F1 for alternate solution.

TRIANGLE CIRCLE MILLING AND TAPPING CIRCLE-LINE-TANGENT CIRCLE-CIRCLE-TANGENT

F2.41: Calculator Circle-Circle-Tangent Type: Cross Example

HELP SEARCH DRILL TABLE CALCULATOR

CALCULATOR CIRCLE-CIRCLE TANGENT

0.000000000  
LOAD + - \* /

CIRCLE1 X	5.0000
CIRCLE1 Y	3.0000
RADIUS 1	2.0000
CIRCLE2 X	0.0000
CIRCLE2 Y	0.0000
RADIUS 2	1.0000

TANGENT A X	3.2353
Y	3.9412
TANGENT B X	5.0000
Y	1.0000
TANGENT C X	0.8824
Y	-0.4706
TANGENT D X	0.0000
Y	1.0000

TYPE: CROSS

Use F and T to form G-code. Press F1 for alternate solution.

TRIANGLE CIRCLE MILLING AND TAPPING CIRCLE-LINE-TANGENT CIRCLE-CIRCLE-TANGENT

## 2.6 More Information Online

For updated and supplemental information, including tips, tricks, maintenance procedures, and more, go to [www.HaasCNC.com](http://www.HaasCNC.com) and select the **Resource Center**.

# Chapter 3: Operation

## 3.1 Machine Power-Up

1. Press and hold **[POWER ON]** until the Haas logo appears.  
The machine performs a self-test and then displays either the **HAAS START UP** page, the **MESSAGES** page (if a message was left), or the **ALARMS** page. In any case, the control will be in **SETUP: ZERO** mode with one or more alarms present.
2. Press **[RESET]** to clear each alarm. If an alarm cannot be cleared, the machine may need service. Call your Haas Factory Outlet for assistance.

**WARNING:**

*Before you do the next step, remember that automatic motion begins immediately when you press **[POWER UP/RESTART]**. Make sure the motion path is clear. In open-frame machines, stay clear of the spindle, machine table, and tool changer.*

3. After the alarms are cleared, the machine must return all axes to zero and establish a reference point called Home from which all operations start. To home the machine, press **[POWER UP/RESTART]**.

The axes rapid toward home, then stop moving when the machine finds the home switches.

When this procedure is complete, the control displays the **OPERATION:MEM** mode. The machine is ready to run.

## 3.2 Spindle Warm-Up Program

If your machine's spindle has been idle for more than 4 days, you must run the spindle warm-up program before you use the machine. This program brings the spindle up to speed slowly, which distributes the lubrication and allows the spindle to thermally stabilize.

A 20-minute warm-up program (002020) is included in the program list of every machine. If you use the spindle at consistent high speeds, you should run this program every day.

## 3.3 Device Manager

The Device Manager shows you the available memory devices and their contents in a tabbed menu. For information on navigating tabbed menus in the Haas control, refer to page 65.



**NOTE:**

*External USB hard drives must be FAT or FAT32 formatted. Do not use NTFS formatted devices.*

This example shows the directory for the USB device in the device manager.

**F3.1:** USB Device Menu

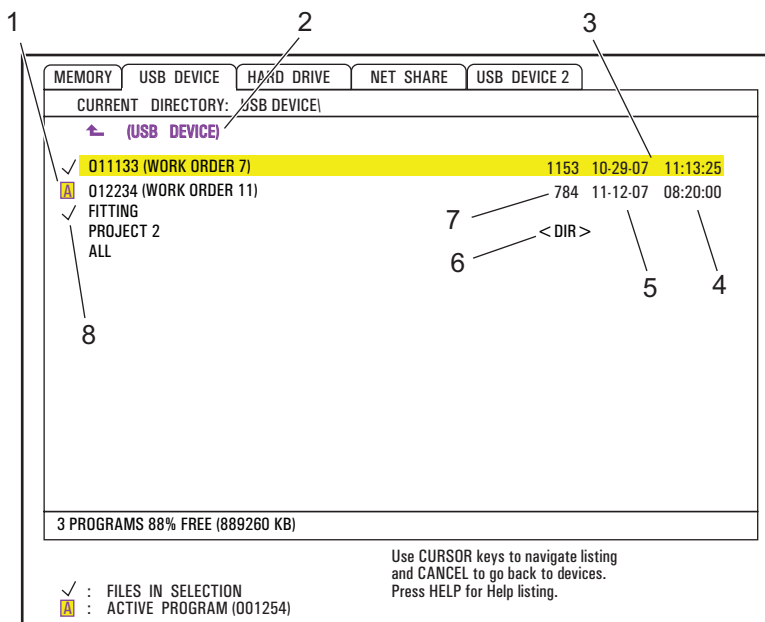

1. Active Program
2. Active Tab
3. Highlighted Program
4. Time
5. Date
6. Subdirectory
7. File Size
8. Selected Program



### 3.3.1 File Directory Systems

Data storage devices such as USB sticks or hard disks usually have a directory structure (sometimes called a “folder” structure), with a root that contains directories which may contain further directories, many levels deep. You can navigate and manage directories on these devices in the device manager.

**NOTE:**

*The MEMORY tab in the device manager gives a flat list of programs saved in the machine’s memory. There are no further directories in this list.*

### Navigating Directories

1. Highlight the directory you want to open. Directories have a <DIR> designation in the file list, then press **[ENTER]**.
2. To return to the previous directory level, highlight the directory name at the top of the file list (it also has an arrow icon). Press **[ENTER]** to go to that directory level.

### Directory Creation

You can add directories to the file structure of USB memory devices, hard drives, and your net share directory.

1. Navigate to the device tab and the directory where you want to place your new directory.
2. Type the new directory name and press **[INSERT]**.  
The new directory appears in the file list with the <DIR> designation.

### 3.3.2 Program Selection

When you select a program, it becomes active. The active program appears in the main **EDIT:EDIT** mode window, and it is the program that the control runs when you press **[CYCLE START]** in **OPERATION:MEM** mode.

1. Press **[LIST PROGRAM]** to display the programs in memory. You can also use the tabbed menus to select programs from other devices in the device manager. Refer to page **65** for more information on tabbed menu navigation.
2. Highlight the program you want to select and press **[SELECT PROGRAM]**. You can also type an existing program name and press **[SELECT PROGRAM]**.

The program becomes the active program.

If the active program is in **MEMORY**, it is designated with the letter **A**. If the program is on a USB memory device, the hard drive, or net share, it is designated with **FNC**.

3. In **OPERATION:MEM** mode, you can type an existing program name and press the **[UP]** or **[DOWN]** cursor arrow to quickly change programs.

### 3.3.3 Program Transfer

You can transfer numbered programs, settings, offsets, and macro variables between machine memory and connected USB, hard drive, or net share devices.

#### File Name Convention

Files intended for transfer to and from the machine control should be named with an (8)-character filename and (3)-character extension; for example: program1.txt. Some CAD/CAM programs use “.NC” as a file extension which is also acceptable.

File extensions are for the benefit of PC applications; the CNC control ignores them. You can name files with the program number and no extension, but some PC applications may not recognize the file without the extension.

Files developed in the control will be named with the letter “O” followed by 5 digits. For example, O12345.

#### Copying Files

1. Highlight a file and press **[ENTER]** to select it. A check mark appears next to the file name.
2. Once all programs are selected, press **[F2]**. This will open the **Copy To** window. Use the cursor arrows to select the destination and press **[ENTER]** to copy the program. Files copied from the control’s memory to a device will have the extension *.NC* appended to the file name. However the name can be changed by navigating to the destination directory, entering a new name, and then pressing **[F2]**.

### 3.3.4 Deleting Programs

**NOTE:**

*You cannot undo this process. Be sure to have backups of data that you may want to load on the control again. You cannot press **[UNDO]** to recover a deleted program.*

1. Press **[LIST PROGRAM]** and select the device tab that contains the programs you want to delete.
2. Use the **[UP]** or **[DOWN]** cursor arrows to highlight the program number.
3. Press **[ERASE PROGRAM]**.

**NOTE:**

*You cannot delete the active program.*

4. Press **[Y]** at the prompt to delete the program, or **[N]** to cancel the process.
5. To delete multiple programs:
  - a. highlight each program you want to delete and press **[ENTER]**. This places a check mark next to each program name.
  - b. Press **[ERASE PROGRAM]**.
  - c. Answer the **Y/N** prompt for each program.
6. If you want to delete all of the programs in the list, select **ALL** at the end of the list and press **[ERASE PROGRAM]**.

**NOTE:**

*There are some important programs that may be included with the machine, such as O02020 (spindle warm-up) or macro programs (O09XXX). Save these programs to a memory device or PC before you erase all programs. You can also use Setting 23 to protect O09XXX programs from deletion.*

### 3.3.5 Maximum Number of Programs

The program list in MEMORY can contain up to 500 programs. If the control contains 500 programs and you try to create a new program, the control returns the message *DIR FULL*, and your new program is not created.

Remove some programs from the program list to create new programs.

### 3.3.6 File Duplication

To duplicate a file:

1. Press **[LIST PROGRAM]** to access the Device Manager.
2. Select the **Memory** tab.
3. Cursor to the program to duplicate.
4. Type a new program number (Onnnnn) and press **[F2]**.  
The highlighted program is duplicated with the new name, and it is made the active program.
5. To duplicate a program to a different device, cursor to the program without typing a new program number and press **[F2]**.  
A popup menu lists destination devices.
6. Select a device and press **[ENTER]** to duplicate the file.
7. To copy multiple files, press **[ENTER]** to place a check mark at each file name.

### 3.3.7 Changing Program Numbers

You can change a program number

1. Highlight the file.
2. Type a new name.
3. Press **[ALTER]**.

#### Program Number Change (in Memory)

To change the number of a program in **MEMORY**:

1. Make the program the active program. Refer to page **77** for more information on the active program.
2. Enter the new program number in **EDIT** mode
3. Press **[ALTER]**.

The program number changes to the number you specified.

If the new program name already exists in **MEMORY**, the control returns the message *Prog exists*, and the program name does not change.

## 3.4 Basic Program Search

You can search a program for specific codes or text in **MDI**, **EDIT** or **MEMORY** mode.

**NOTE:**

*This is a quick-search function that will find the first match in the search direction that you specify. You can use the Advanced Editor for a more full-featured search. Refer to page 120 for more information on the Advanced Editor search function.*

1. Type the text you want to search the active program for.
2. Press the **[UP]** or **[DOWN]** cursor arrow.

The **[UP]** cursor arrow searches toward the start of the program from the current cursor position. The **[DOWN]** cursor arrow searches toward the end of the program. The first match found appears highlighted.

## 3.5 RS-232

RS-232 is one way of connecting the Haas CNC control to a computer. This feature enables the programmer to upload and download programs, settings, and tool offsets from a PC.

You need a 9-pin to 25-pin null modem cable (not included) or a 9-pin to 25-pin straight Through cable with a null modem adapter to link the CNC control with the PC. There are two styles of RS-232 connections: the 25-pin connector and the 9-pin connector. The 9-pin connector is more commonly used on PCs. Plug the 25-pin connector end into the connector on the Haas machine located on the side panel of the control cabinet at the back of the machine.

**NOTE:**

*Haas Automation does not supply null modem cables.*

## 3.5.1 Cable Length

The following lists baud rate and the respective maximum cable length.

### T3.1: Cable Length

Baud rate	Max. cable length (ft)
19200	50
9600	500
4800	1000
2400	3000

## 3.5.2 Machine Data Collection

Machine Data Collection is enabled by Setting 143, which allows the user to extract data from the control using a Q command sent through the RS-232 port (or by using an optional hardware package). This feature is software-based and requires an additional computer to request, interpret, and store data from the control. The remote computer can also set certain Macro variables.

### Data Collection Using the RS-232 Port

The control responds to a Q command only when Setting 143 is ON. The following output format is used:

```
<STX> <CSV response> <ETB> <CR/LF> <0x3E>
```

- *STX* (0x02) marks the start of data. This control character is for the remote computer.
- *CSV response* is Comma Separated Variables, one or more data variables separated by commas.
- *ETB* (0x17) marks the end of the data. This control character is for the remote computer.
- *CR/LF* tells the remote computer the data segment is complete and to move to the next line.
- *0x3E* Displays the > prompt.

If the control is busy, it outputs *Status*, *Busy*. If a request is not recognized, the control outputs *Unknown* and a new prompt >. The following commands are available:

## T3.2: Remote Q Commands

Command	Definition	Example
Q100	Machine Serial Number	>Q100 SERIAL NUMBER, 3093228
Q101	Control Software Version	>Q101 SOFTWARE, VER M18.01
Q102	Machine Model Number	>Q102 MODEL, VF2D
Q104	Mode (LIST PROG, MDI, etc.)	>Q104 MODE, (MEM)
Q200	Tool Changes (total)	>Q200 TOOL CHANGES, 23
Q201	Tool Number in use	>Q201 USING TOOL, 1
Q300	Power-on Time (total)	>Q300 P.O. TIME, 00027:50:59
Q301	Motion Time (total)	>Q301 C.S. TIME, 00003:02:57
Q303	Last Cycle Time	>Q303 LAST CYCLE, 000:00:00
Q304	Previous Cycle Time	>Q304 PREV CYCLE, 000:00:00
Q402	M30 Parts Counter #1 (resettable at control)	>Q402 M30 #1, 553
Q403	M30 Parts Counter #2 (resettable at control)	>Q403 M30 #2, 553
Q500	Three-in-one (PROGRAM, Oxxxx, STATUS, PARTS, xxxxx)	>Q500 STATUS, BUSY
Q600	Macro or system variable	>Q600 801 MACRO, 801, 333.339996

The user has the ability to request the contents of any macro or system variable by using the Q600 command, for example, Q600 xxxx. This will display the contents of macro variable xxxx on the remote computer. In addition, macro variables #1-33, 100-199, 500-699 (note that variables #550-580 are unavailable if the mill is equipped with a probing system), 800-999 and #2001 thru #2800 can be written to using an E command, for example, Exxxx yyyyyy.yyyyyy where xxxx is the macro variable and yyyyyy.yyyyyy is the new value.

**NOTE:**

*This command should be used only when there are no alarms present.*

## Data Collection Using Optional Hardware

This method is used to provide machine status to a remote computer, and is enabled with the installation of an 8 Spare M-code relay board (all 8 become dedicated to below functions and cannot be used for normal M-code operation), a power-on relay, an extra set of **[EMERGENCY STOP]** contacts, and a set of special cables. Contact your dealer for pricing information on these parts.

Once installed, output relays 40 through 47, a power-on relay and the **[EMERGENCY STOP]** switch are used to communicate the status of the control. Parameter 315 bit 26, Status Relays, must be enabled. Standard spare M-codes are still available for use.

The following machine statuses will be available:

- E-STOP contacts. This will be closed when the **[EMERGENCY STOP]** is pushed.
- Power ON - 115 VAC. Indicates the control is turned ON. It should be wired to a 115 VAC coil relay for interface.
- Spare Output Relay 40. Indicates that the control is In-Cycle (running.)
- Spare Output Relay 41 and 42:
  - 11 = MEM mode & no alarms (AUTO mode.)
  - 10 = MDI mode & no alarms (Manual mode.)
  - 01 = Single Block mode (Single mode)
  - 00 = Other modes (zero, DNC, jog, list program, etc.)
- Spare Output Relay 43 and 44:
  - 11 = Feed Hold stop (Feed Hold.)
  - 10 = M00 or M01 stop
  - 01 = M02 or M30 stop (Program Stop)
  - 00 = None of the above (could be single block stop or RESET.)
- Spare Output Relay 45 Feed Rate Override is active (Feed Rate is NOT 100%)
- Spare Output Relay 46 Spindle Speed Override active (Spindle Speed is NOT 100%)
- Spare Output Relay 47 Control is in EDIT mode

## 3.6 File Numeric Control (FNC)

You can run a program directly from its place on your network or from a storage device, such as a USB drive. From the Device Manager screen, highlight a program on the selected device and press **[SELECT PROGRAM]**.

You can call subprograms in an FNC program, but those subprograms must be in the same file directory as the main program.

If your FNC program calls G65 macros or aliased G/M subprograms, they must be in **MEMORY**.





**CAUTION:**

You can edit subprograms while the CNC program runs. Be careful when you run an FNC program that might have changed since the last time it ran.

## 3.7 Direct Numeric Control (DNC)

Direct Numeric Control (DNC) is a method of loading a program into the control and running the program as it is received through the RS-232 port. This feature differs from a program loaded through the RS-232 port in that there is no limit to the size of the CNC program. The program is run by the control as it is sent to the control; it is not stored in the control.

### F3.2: DNC Waiting and Received Program

<pre>PROGRAM (DNC)          N00000000 WAITING FOR DNC. . .  DNC RS232</pre>	<pre>PROGRAM (DNC)          N00000000 O01000 ; (G-CODE FINAL QC TEST CUT) ; (MATERIAL IS 2x8x8 6061 ALUMINUM) ; ; (MAIN) ; ; M00 ; (READ DIRECTIONS FOR PARAMETERS AND SETTINGS) ; (FOR VF - SERIES MACHINES W/4TH AXIS CARDS) ; (USE / FOR HS, VR, VB, AND NON - FORTH MACHINES) ; (CONNECT CABLE FOR HASC BEFORE STARTING THE PROGRAM) ; (SETTINGS TO CHANGE) ; (SETTING 31 SET TO OFF) ; ; ; DNC RS232 DNC END FOUND</pre>
---	---

### T3.3: Recommended RS-232 Settings for DNC

Settings	Variable	Value
11	Baud Rate Select:	19200
12	Parity Select	NONE
13	Stop Bits	1
14	Synchronization	XMODEM
37	RS-232 Data Bits	8

1. DNC is enabled using Parameter 57 bit 18 and Setting 55. Turn the parameter bit on (1) and change Setting 55 to **ON**.
2. It is recommended that DNC be run with XMODEM or parity selected because an error in transmission will then be detected and will stop the DNC program without crashing. The settings between the CNC control and the other computer must match. To change the setting in the CNC control, press **[SETTING/GRAPHIC]** and scroll to the RS-232 settings (or enter 11 and press the up or down arrow).
3. Use the **[UP]** and **[DOWN]** cursor arrows to highlight the variables and the left and right arrows to change the values.
4. Press **[ENTER]** when the proper selection is highlighted.
5. DNC is selected by pressing **[MDI/DNC]** twice. DNC needs a minimum of 8k bytes of user memory available. This can be done by going to the List Programs page and checking the amount of free memory on the bottom of the page.
6. The program sent to the control must begin and end with a %. The data rate selected (Setting 11) for the RS-232 port must be fast enough to keep up with the rate of block execution of the program. If the data rate is too slow, the tool may stop in a cut.
7. Start sending the program to the control before **[CYCLE START]** is pushed. Once the message *DNC Prog Found* is displayed, Press **[CYCLE START]**.

### 3.7.1 DNC Notes

While a program is running in DNC, modes cannot be changed. Therefore, editing features such as Background Edit is not available.

DNC supports drip mode. The control will perform one block (command) at a time. Each block will be performed immediately with no block look-ahead. The exception is when Cutter Compensation is commanded. Cutter Compensation requires three blocks of motion commands to be read prior to a compensated block being performed.

Full duplex communication during DNC is possible by using the **G102** command or **DPRNT** to output axes coordinates back to the controlling computer.

## 3.8 Graphics Mode

A safe way to troubleshoot a program is to run it in Graphics mode. No movement will occur on the machine, instead the movement will be illustrated on the screen.

Graphics mode can be run from Memory, MDI, DNC, FNC, or Edit modes. To run a program:

1. Press **[SETTING/GRAPHIC]** until the **GRAPHICS** page is displayed. Or press **[CYCLE START]** from the active program pane in Edit mode to enter Graphics mode.
2. To run DNC in graphics, press **[MDI/DNC]** until DNC mode is active, then go to graphics display and send the program to the machine's control (See the DNC section).
3. There are three helpful display features in Graphics mode that can be accessed by pressing **[F1] - [F4]**. **[F1]** is the help button, which will give a short description of each of the functions possible in graphics mode. **[F2]** is the zoom button, which highlights an area using the arrow buttons, **[PAGE UP]** and **[PAGE DOWN]** to control the zoom level, and pressing the **[ENTER]** button. **[F3]** and **[F4]** are used to control the simulation speed.

**NOTE:**

*Not all machine functions or motions are simulated in graphics.*

## 3.9 Tooling

This section describes tool management in the Haas control: commanding tool changes, loading tools into holders, and Advanced Tool Management.

### 3.9.1 Tool Functions (Tnn)

The **Tnn** code is used to select the next tool to be placed in the spindle from the tool changer. The **T** address does not start the tool change operation; it only selects which tool will be used next. **M06** will start a tool change operation; for example, **T1M06** puts tool 1 in the spindle.

**NOTE:**

*There is no X or Y motion required prior to performing a tool change; however, if the work piece or fixture is large, position X or Y prior to a tool change in order to prevent a crash between the tools and the part or fixture.*

A tool change can be commanded with the X, Y, and Z Axes in any position. The control will bring the Z Axis up to the machine zero position. The control will move the Z Axis to a position above machine zero during a tool change but will never move below machine zero. At the end of a tool change, the Z Axis will be at machine zero.

## 3.9.2 Tool Holders

There are several different spindle options for Haas mills. Each of these types requires a specific tool holder. The most common spindles are 40- and 50-taper. 40-taper spindles are divided into two types, BT and CT; these are referred to as BT40 and CT40. The spindle and tool changer in a given machine are capable of holding only one tool type.

### Tool Holder Care

1. Make sure that tool holders and pull studs are in good condition and tightened together securely or they may stick in the spindle.

**F3.3:** Tool Holder Assembly, 40-Taper CT Example: [1] Pull Stud, [2] Tool (Endmill).

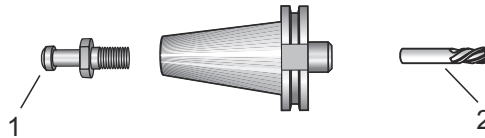

2. Clean the tool holder taper body (the part that goes into the spindle) with a lightly oiled rag to leave a film, which helps prevent rusting.

---

## Pull Studs

A pull stud or retention knob is required to secure the tool holder into the spindle. Pull studs are threaded into the top of the tool holder and are specific to the type of spindle. The following chart describes the pull studs used in Haas mills. Do not use short shaft or pull studs with a sharp right angle (90-degree) head; they will not work and will cause serious damage to the spindle.

F3.4: Pull Stud Chart

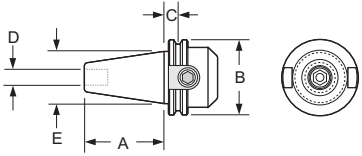
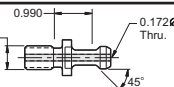
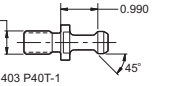
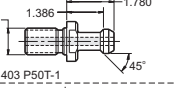
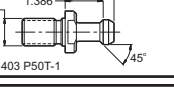
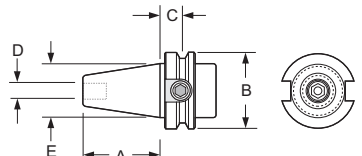
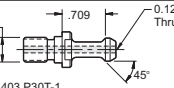
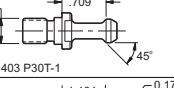
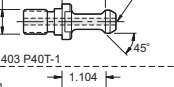
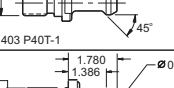
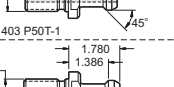
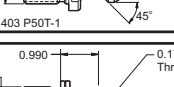
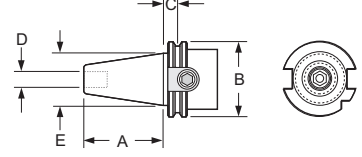
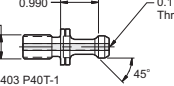
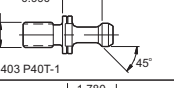
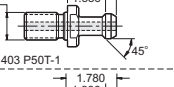
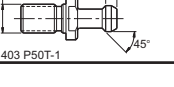
Tool Holders/Pull Studs						
<b>CT CAT V-Flange</b>						Kit #
		40T	20-7594 (TSC)	5/8-11 Inch Threads		TPS24CT
				20-7164 (non-TSC)	5/8-11 Inch Threads	
		50T	22-0075 (TSC)	1"-8 Inch Threads		TPS24CT50
				22-0039 (non-TSC)	1"-8 Inch Threads	
	A	B	C	D	E	
40T	2.69	2.50	.44	5/8"-11	1.75	
50T	4.00	3.87	.44	1"-8	2.75	
<b>BT MAS 403</b>						Kit #
		30T	59-1111 (TSC)	M12x1.75 Threads		N/A
				59-0336 (non-TSC)	M12x1.75 Threads	
		40T	20-7595 (TSC)	M16 X 2 Threads		TPS24BT
				20-7165 (non-TSC)	M16 X 2 Threads	
		50T	22-7171 (TSC)	M24 X 3 Threads		TPS24E50
				22-7170 (non-TSC)	M24 X 3 Threads	
	A	B	C	D	E	
30T	1.875	1.812	.4375	M12x1.75	1.25	
40T	2.57	2.48	.65	M16X2	1.75	
50T	4.00	3.94	.91	M24X3	2.75	
<b>DIN-69871 (MIKRON) ISO-7388</b>						Kit #
		40T	20-7556 (TSC)	M16 X 2 Threads		TPS24E
				20-2232 (non-TSC)	M16 X 2 Threads	
		50T	22-7171 (TSC)	M24 X 3 Threads		TPS24E50
				22-7170 (non-TSC)	M24 X 3 Threads	
	A	B	C	D	E	
40T	2.69	2.50	.44	M16X2	1.75	
50T	4.00	3.84	.44	M24X3	2.75	

**NOTE:** CT 40T Pullstud = One Identification Groove  
 BT 40T Pullstud = Two Identification Grooves  
 MIKRON 40T Pullstud = Three Identification Grooves

### 3.9.3 Advanced Tool Management Introduction

Advanced Tool Management (ATM) allows the programmer to setup and access duplicate tools for the same or a series of jobs.

Duplicate or backup tools are classified into specific groups. The programmer specifies a group of tools instead of a single tool in the G-code program. ATM tracks the usage of individual tools in each tool group and compares it to user defined limits. Once a limit (e.g. number of times used, or tool load) is reached the mill automatically chooses one of the other tools in the group the next time that tool is needed.

When a tool expires, the beacon flashes orange and the tool life screen automatically displays.

The ATM page is located in the Current Commands mode. Press **[CURRENT COMMANDS]** and **[PAGE UP]** until the ATM screen appears. Bypass the Pocket Tool Table.

**F3.5:** Advanced Tool Management Window: [1] Active window label, [2] Tool group window, [3] Allowed limits window, [4] Tool data window, [5] Help text

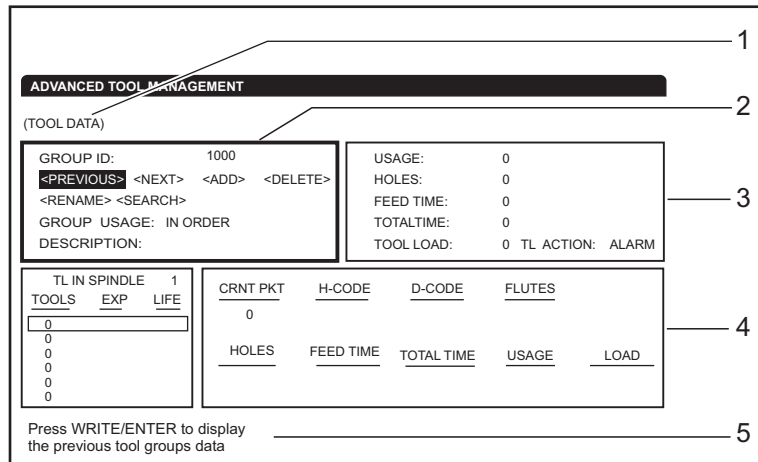

**Tool Group** - In the Tool Group Window the operator defines the tool groups used in the programs.

**Previous** – Highlighting **<PREVIOUS>** and pressing **[ENTER]** changes the display to the previous group.

**Next** – Highlighting **<NEXT>** and pressing **[ENTER]** changes the display to next group.

**Add** – Highlight **<ADD>**, enter a number between 1000 and 2999, and press **[ENTER]** to add a tool group.

Delete – Use <PREVIOUS> or <NEXT> to scroll to the group to delete. Highlight <DELETE> and press [ENTER]. Confirm the deletion; answering [Y] completes the deletion; answering [N] cancels the deletion.

Rename - Highlight <RENAME>, enter a number 1000 and 2999 and press [ENTER] to renumber the group ID.

Search - To search for a group, highlight <SEARCH>, enter a group number and press [ENTER].

Group Id – Displays the group ID number.

Group Usage – Enter the order in which the tools in the group are called. Use the left and right cursor keys to select how the tools are used.

Description – Enter a descriptive name of the tool group.

Allowed Limits - The Allowed Limits window contains the user defined limits to determine when a tool is worn out. These variables affect every tool in the group. Leaving any variable set to zero causes them to be ignored.

Feed Time – Enter the total amount of time, in minutes, a tool is used in a feed.

Total Time – Enter the total time, in minutes, a tool is used.

Tool Usage – Enter the total times a tool is used (number of tool changes).

Holes – Enter the total number of holes a tool is allowed to drill.

Tool Load – Enter the maximum tool load (in percent) for the tools in the group.

TL Action\* – Enter the automatic action to be taken when the maximum tool load percentage is reached. Use the left and right cursor keys to select the automatic action.

Tool Data

TL in Spindle – Tool in the spindle.

Tool – Used to add or remove a tool from a group. To add a tool press [F4] until the Tool Data window is outlined. Use the cursor keys to highlight any of the areas under the Tool heading and enter a tool number. Entering zero will clear the tool or highlighting the tool number and pressing [ORIGIN] resets the H-Code, D-Code, and Flutes data to the default values.

EXP (Expire) – Used to manually obsolete a tool in the group. To obsolete a tool, enter a [\*], or to clear an obsolete tool, ( \* ), press [ENTER].

Life – The percentage of life left in a tool. This is calculated by the CNC control, using actual tool data and the limits the operator entered for the group.

CRNT PKT – The tool changer pocket the highlighted tool is in.



H-Code – The H-code (tool length) that will be used for the tool. H-code cannot be edited unless Setting 15 H & T Code Agreement is set to **OFF**. The operator can change the H-code by entering a number and pressing **[ENTER]**. The number entered corresponds to the tool number in the tool offsets display.

D-Code – The D-code that is used for that tool. D-code is changed by entering a number and pressing **[ENTER]**.

**NOTE:**

*By default the H and D-codes in Advanced Tool Management are set to equal the tool number that is added to the group.*

Flutes – The number of flutes on the tool. This can be edited by selecting it, entering a new number, and pressing **[ENTER]**. This is the same as the **Flutes** column listed on the tool offsets page.

Highlighting any of the following sections (Holes through Load) and pressing **[ORIGIN]** clears their values. To change the values, highlight the value in the specific category, enter a new number and press **[ENTER]**.

Load – The maximum load, in percent, exerted on the tool.

Holes – The number of holes the tool has drilled/ tapped/ bored using Group 9 canned cycles.

Feed Time – The amount of time, in minutes , the tool has been in a feed.

Total Time – The total amount of time, in minutes, the tool has been used.

Usage – The number of times the tool has been used.

## Tool Group Setup

To add a tool group:

1. Press **[F4]** until the Tool Group window is outlined.
2. Use the cursor keys until **<ADD>** is highlighted.
3. Enter a number between 1000 and 2999 (this will be the group ID number).
4. Press **[ENTER]**.
5. To change a group ID number, highlight the **<RENAME>** feature.
6. Enter a new number.
7. Press **[ENTER]**.

## Tool Group Usage

A tool group must be setup prior to using a program. To use a tool group in a program:

1. Set up a tool group.
2. Substitute the tool group ID number for the tool number and for the H-codes and D-codes in the program. Refer to this program for an example of the new programming format.

Example:

```
T1000 M06 (tool group 1000)
G00 G90 G55 X0.565 Y-1.875 S2500 M03
G43 H1000 Z0.1 (H-code 1000 same as group ID number)
G83 Z-0.62 F15. R0.1 Q0.175
X1.115 Y-2.75
X3.365 Y-2.87
G00 G80 Z1.0
T2000 M06 (use tool group 2000)
G00 G90 G56 X0.565 Y-1.875 S2500 M03
G43 H2000 Z0.1 (H-code 2000 same as group ID number)
G83 Z-0.62 F15. R0.1 Q0.175
X1.115 Y-2.75
X3.365 Y-2.875
G00 G80 Z1.0
M30
```

## Advanced Tool Management Macros

Tool Management can use macros to obsolete a tool within a tool group. Macros 8001 to 8200 represent tools 1 through 200. By setting one of these macros to 1, the operator can expire a tool. For example:

8001 = 1 (this will expire tool 1 and it will no longer be used)

8001 = 0 (if tool 1 was expired manually or with a macro, then setting macro 8001 to 0 will make tool 1 available again for use)

Macro variables 8500-8515 enable a G code program to obtain tool group information. When a tool group ID number is specified using macro 8500, the control will return the tool group information in macro variables #8501 through #8515.

See the variables #8500-#8515 in the Macros chapter for the macro variable data label information.

Macro variables #8550-#8564 enable a G code program to obtain individual tool information. When an individual tool ID number is specified using macro #8550, the control will return the individual tool information in macro variables #8551-#8564. Additionally, a user can specify an ATM group number using macro 8550. In this case, the control will return the individual tool information for the current tool in the specified ATM tool group using macro variables 8551-8564. See the description for variables #8550-#8564 in the Macros chapter. The values in these macros provide data that is also accessible from macros starting at 1601, 1801, 2001, 2201, 2401, 2601, 3201, and 3401 and for macros starting at 5401, 5501, 5601, 5701, 5801, and 5901. These first 8 sets provide access for tool data for tools 1-200; the last 6 sets provide data for tools 1-100. Macros 8551-8564 provide access to the same data, but for tools 1-200 for all data items.

## Save and Restore Advanced Tool Management Tables

The control can save and restore the variables associated with the Advanced Tool Management (ATM) feature to the USB drive and RS-232. These variables hold the data that is entered on the ATM screen.

1. The information can be saved, either as part of an overall backup program by using the **[LIST PROGRAM]/ Save/Load** window (**[F4]**).  
When the Advanced Tool Management data is saved as part of an overall backup, the system creates a separate file with a .ATM extension.
2. The ATM data can be saved and restored via the RS-232 port by pressing **[SEND]** and **[RECEIVE]** while the Advanced Tool Management screen is displayed.

## 3.10 Tool Changer

There are two types of tool changers available for the Haas mills; these are the carousel (umbrella) style and the side mount tool changer. Both types are commanded in the same manner, but each one is set up differently.

1. Before loading tools, the mill must be zero returned. This usually is done at machine power up. If not, press **[POWER UP/RESTART]**.
2. Manually operate the tool changer using the Tool Release button and **[ATC FWD]** and **[ATC REV]**. There are two tool release buttons; one on the spindle head cover and the second on the keyboard, labeled **[TOOL RELEASE]**.

## 3.10.1 Tool Changer Safety Notes

If the cage door is opened while a tool change is in progress, the tool change will stop and not resume until the cage door is closed. However, any machining operations that are in progress will continue.

If the switch is turned to **[MANUAL]** while a tool change is in progress, current tool changer motion will be completed. The next tool change will not execute until the switch is turned back to **[AUTO]**. Any machining operations that are in progress will continue.

The carousel will rotate one position whenever **[CW]** or **[CCW]** is pressed once, while the switch is set to **[MANUAL]**.

During tool changer recovery, if the cage door is open or the switch is in the **[MANUAL]** position and **[RECOVER]** is pressed, a message is displayed telling the operator the door is open or is in manual mode. The operator must close the door and set the switch to the automatic position in order to continue.

## 3.10.2 Loading the Tool Changer



**CAUTION:**

*Do not exceed the maximum tool changer specifications. Extremely heavy tool weights should be distributed evenly. This means heavy tools should be located across from one another, not next to each other. Ensure there is adequate clearance between tools in the tool changer; this distance is 3.6" for a 20-pocket.*



**NOTE:**

*Low air pressure or insufficient volume will reduce the pressure applied to the tool release piston and will slow down tool change time or will not release the tool.*



**WARNING:**

*Keep clear of the tool changer during power up, power down, and any tool changer operations.*

Tools are always loaded into the tool changer by first installing the tool into the spindle. Never load a tool directly into the tool changer.

**CAUTION:**

*Tools that make a loud bang when being released indicate a problem and should be checked before serious damage to the tool changer occurs.*

## Tool Loading for a Side-Mount Tool Changer

**NOTE:**

*A normal size tool has a diameter of less than 3" for 40-taper machines, or less than 4" for 50-taper machines. Tools larger than these measurements are considered large size.*

1. Make sure your tool holders have the correct pull stud type for the mill.
2. Press **[CURRENT COMMANDS]**. Press **[PAGE UP]** or **[PAGE DOWN]** until you see the **POCKET TOOL TABLE**.
3. Clear any current "Large" or "Heavy" tool designations. Use the cursor keys to scroll to any tool pocket that has an **L** or **H** next to it. Press **[SPACE]**, then **[ENTER]** to clear the "Large" or "Heavy" tool designations. To clear all designations, press **[ORIGIN]** and select the **CLEAR CATEGORY FLAGS** option.

**F3.6:** A Large and Heavy Tool (left), and a Heavy (not Large) Tool (right)

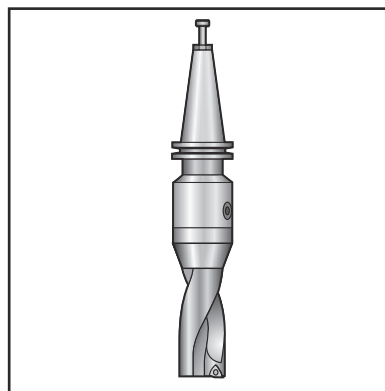
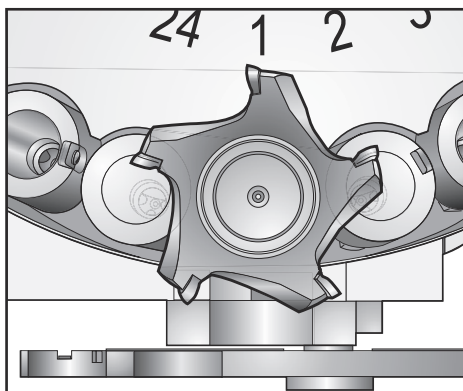

4. Press Origin to reset the tool pocket table to default values. This will place tool 1 in the spindle, tool 2 in pocket 1, tool 3 in pocket 2, etc. This clears the previous tool pocket table settings, and it rennumbers the tool pocket table for the next program. You can also press **[ORIGIN]** and select **SEQUENCE ALL POCKETS** to reset the tool pocket table.



**NOTE:**

*There cannot be two different tool pockets holding the same tool number. Entering a tool number already displayed in the tool pocket table will result in an “Invalid Number” error.*

5. Determine if your program will need any large tools. A large tool has a diameter of greater than 3" for 40-taper machines and greater than 4" for 50-taper machines. If large tools are not used, proceed to Step 7. If large tools are used, proceed to the next step.
6. Organize the tools to match to the CNC program. Determine the numerical positions of large tools and designate those pockets as Large in the tool pocket table. To designate a tool pocket as “Large”, scroll to that pocket, press **[L]**, then **[ENTER]**.



**CAUTION:**

*You cannot place a large tool in the tool changer if one or both of the surrounding pockets already contain tools. Doing so will cause the tool changer to crash. Large tools must have the surrounding pockets empty. However, large tools can share adjoining empty pockets.*

7. Take tool 1 in hand and insert the tool (pull stud first) into the spindle. Turn the tool so that the two cutouts in the tool holder line up with the tabs of the spindle. Push the tool upward and press the tool release button. When the tool is fitted into the spindle, release the tool release button.

**F3.7:** Inserting a Tool Into the Spindle: [1] Tool release button.

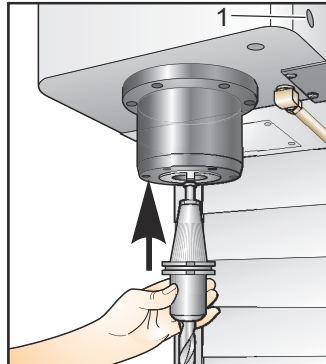

---

## High-Speed Side-Mount Tool Changer

The high-speed side-mount tool changer has an additional tool assignment, which is "Heavy". Heavy tools are defined as tools weighing more than 4 pounds. If a tool, heavier than 4 pounds is used, the tool must be entered in the table with an "H" (Note: All large tools are considered heavy). During operation an "h" in the tool table denotes a heavy tool in a large pocket.

As a safety precaution, the tool changer will run at a maximum of 25% of the normal speed if changing a heavy tool. The pocket up/down speed is not slowed down. The control restores the speed to the current rapid, once the tool change is complete. If problems are encountered changing unusual or extreme tooling, contact your dealer for assistance.

H - Heavy, but not necessarily large (large tools require empty pockets on either side).

h - Heavy small diameter tool in a pocket designated for a large tool (must have empty pocket on both sides). The lower case "h" and "l" is placed by the control; never enter a lower case "h" or "l" into the tool table.

l - Small diameter tool in a pocket reserved for a large tool in the spindle.

Large tools are assumed to be heavy.

Heavy tools are not assumed to be large.

On non-high speed tool changers, "H" and "h" have no effect.

### Using '0' for a Tool Designation

A tool pocket can be labeled as an "always empty" pocket, by entering 0 (zero) for the tool number in the tool table. If this is done the tool changer does not "see" this pocket and will never try to install or retrieve a tool from pockets with a '0' designation.

A zero cannot be used to designate the tool inserted into the spindle. The spindle must always have a tool number designation.

## Moving Tools in the Carousel

Should tools need moving in the carousel, follow this procedure.



**CAUTION:**

*Plan the reorganization of the tools in the carousel ahead of time. To reduce the potential for tool changer crashes, keep tool movement to a minimum. If there are large or heavy tools currently in the tool changer, ensure that they are only moved between tool pockets designated as such.*

### Moving Tools

The tool changer pictured has an assortment of normal size tools. For the purposes of this example, tool 12 will be moved to pocket 18 to create room for a large size tool to be placed in pocket 12.

**F3.8:** Making Room for Large Tools: [1] Tool 12 to Pocket 18, [2] Large tool in Pocket 12.

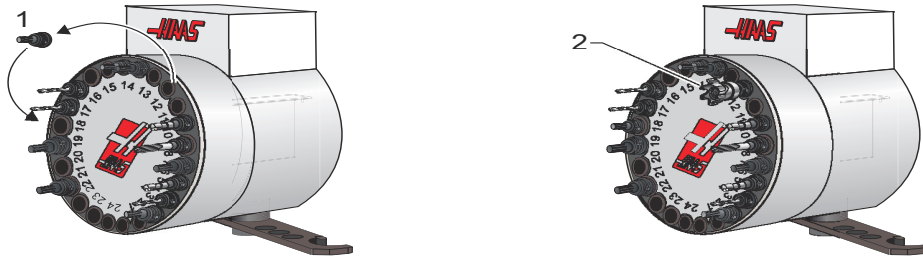

1. Select **MDI** mode. Press **[CURRENT COMMANDS]** and scroll to the **tool pocket table** display. Verify which tool number is in pocket 12.
2. Enter Tnn into the control (where Tnn is the tool number from step 1). Press **ATC FWD**. This will place the tool from pocket 12 into the spindle.
3. Enter P18 into the control, then press **[ATC FWD]** to place the tool currently in the spindle into pocket 18.
4. Scroll to pocket 12 in the tool pocket table and press **L**, **Write/Enter** to designate that pocket as Large.



**NOTE:**

*There cannot be two different tool pockets holding the same tool number. Entering a tool number already displayed in the Tool Pocket table will result in an “Invalid Number” error.*

5. Enter the tool number into **SPNDL** (spindle) on the **tool pocket table**. Insert the tool into the spindle.

**NOTE:**

*Extra-large tools can be programmed as well. An “extra-large” tool is one that takes up three pockets; the diameter of the tool will cover the tool pocket on either side of the pocket it is installed in. Have your HFO change Parameter 315:3 to 1 if a tool this size is needed. The tool table must be updated as now two empty pockets are needed between extra large tools.*

6. Enter **P12** into the control and press **[ATC FWD]**. The tool will be placed into pocket 12.

## Umbrella Tool Changer

Tools are loaded into the umbrella tool changer by first loading the tool into the spindle. To load a tool into the spindle, prepare the tool and then follow these steps:

1. Ensure the tools loaded have the correct pull stud type for the mill.
2. Press **[MDI/DNC]** for MDI mode.
3. Organize the tools to match to the CNC program.
4. Take tool in hand and insert the tool (pull stud first) into the spindle. Turn the tool so that the two cutouts in the tool holder line up with the tabs of the spindle. Push the tool upward while pressing the Tool Release button. When the tool is fitted into the spindle, release the Tool Release button.
5. Press **[ATC FWD]**.
6. Repeat Steps 4 and 5 with the remaining tools until all the tools are loaded.

### 3.10.3 Umbrella Tool Changer Recovery

If the tool changer jams, the control will automatically come to an alarm state. To correct this:



**WARNING:** *Never put your hands near the tool changer unless the EMERGENCY STOP button is pressed first.*

1. Press **[EMERGENCY STOP]**.
2. Remove the cause of the jam.
3. Press **[RESET]** to clear the alarms.
4. Press **[RECOVER]** and follow the directions to reset the tool changer.

### 3.10.4 Side Mount Tool Changer Recovery

If a problem occurred during a tool change, a tool changer recovery needs to be performed. Enter the tool changer recovery mode by:

1. Press **[RECOVER]**. The control will first attempt an automatic recovery.
2. At the tool changer recovery screen, press **[A]** to begin automatic recovery or **[E]** to exit. If the automatic recovery fails, the option appears for a manual recovery.
3. Press **[M]** to continue.
4. In manual mode, follow the instructions and answer the questions to perform a proper tool changer recovery. The entire tool changer recovery process must be completed before exiting. Start the routine from the beginning if you exit the routine early.

### 3.10.5 Side Mount Tool Changer Door and Switch Panel

Mills such as the MDC, EC-300 and EC-400 have a sub-panel to aid tool loading. The Manual/Auto switch must be set to “Auto” for automatic tool changer operation. If the switch is set to “Manual”, the other two buttons, labeled CW and CCW, are enabled and automatic tool changes are disabled. The CW and CCW buttons rotate the tool changer in the clockwise and counterclockwise directions. The door has a switch which detects when the door is open.

**F3.9:** Tool Changer Door and Switch Panel Symbols: [1] Rotate Tool changer Carousel Counter-Clockwise, [2] Rotate Tool Changer Carousel Clockwise, [3] Manual Operation, [4] Automatic Operation.

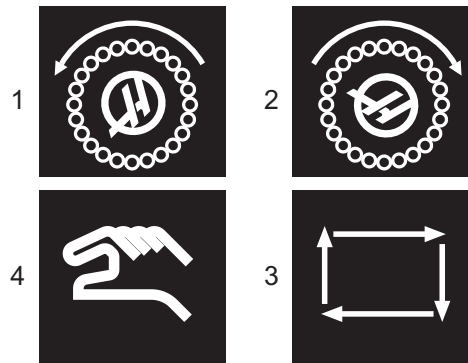

### 3.11 Part Setup

It is necessary to properly secure the part to the table. This can be done a number of ways, using vises, chucks or using T-bolts and toe clamps.

**F3.10:** Part Setup: [1] Toe clamp, [2] Chuck, [3] Vise.

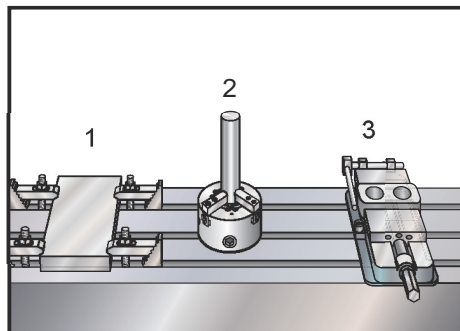

## 3.12 Setting Offsets

To machine a part accurately, the mill needs to know where the part is located on the table and the distance from the tip of the tools to the top of the part (tool offset from home position).

To manually enter offsets:

1. Choose one of the offsets pages.
2. Move the cursor to the desired column.
3. Type the offset number you want to use.
4. Press **[ENTER]** or **[F1]**.  
The value is entered into the column.
5. Enter a positive or negative value and press **[ENTER]** to add the amount entered to the number in the selected column; press **[F1]** to replace the number in the column.

### 3.12.1 Jog Mode

Jog Mode allows each axes to be jogged to a desired location. Before jogging the axes it is necessary to home (beginning axes reference point) the axes. Refer to page **75** for more information on the machine power-up procedure.

To enter jog mode:

1. Press **[HANDLE JOG]**.
2. Press the desired axis (**[+X]**, **[-X]**, **[+Y]**, **[-Y]**, **[+Z]**, **[-Z]**, **[+A/C]** or **[-A/C]**, **[+B]**, or **[-B]**).
3. There are different increment speeds that can be used while in jog mode; they are **[.0001]**, **[.001]**, **[.01]** and **[.1]**. The optional Remote Jog Handle (RJH) can also be used to jog the axes.
4. Press and hold the handle jog buttons or use the **[HANDLE JOG]** control to move the axes.

## 3.12.2 Typical Work Offset Set-up

In order to accurately machine a work piece, the mill needs to know where the part is located on the table. To machine set the part zero offset:

**F3.11:** Part Zero Set

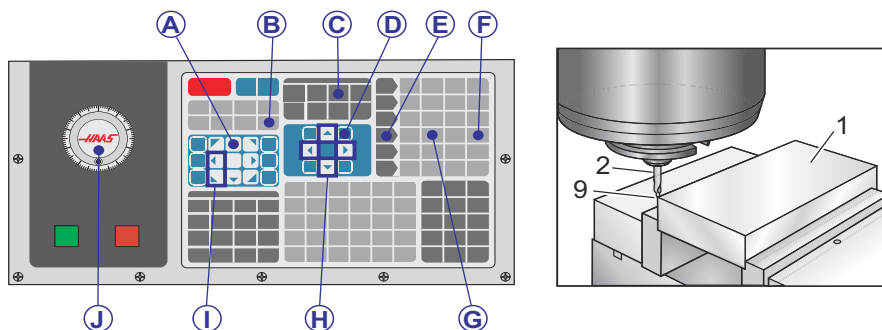

1. Place the material [1] in the vise and tighten.
2. Load a pointer tool [2] in the spindle.
3. Press **[HANDLE JOG]** [A].
4. Press **[.1/100.]** [B] (The mill will move at a fast speed when the handle is turned).
5. Press **[+Z]** [C].
6. Handle jog [D] the Z-Axis approximately 1" above the part.
7. Press **[.001/1.]** [E] (The mill will move at a slow speed when the handle is turned).
8. Handle jog [D] the Z-Axis approximately. 0.2" above the part.
9. Select between the X and Y axes [F] and handle jog [D] the tool to the upper left corner of the part (See illustration [9]).
10. Press **[OFFSET]** [G] until the Work Zero Offset Pane is active.
11. Cursor [I] to G54 Column X.



**CAUTION:**

*In the following step, do not press **[PART ZERO SET]** a third time; doing so will load a value into the Z-Axis. This will cause a crash or Z-Axis alarm when the program is run.*

12. Press **[PART ZERO SET]** [J] to load the value into the X-Axis column. The second press of **[PART ZERO SET]** [J] will load the value into the Y-Axis column.

### 3.12.3 Setting the Tool Offset

The next step is to touch off the tools. This defines the distance from the tip of the tool [1] to the top of the part. Another name for this is Tool Length Offset, which is designated as H in a line of machine code. The distance for each tool is entered into the Tool Offset Table.

**F3.12:** Setting Tool Offset. Tool Length is measured from the tip of the tool [1] to the top of the part [2], with the Z Axis at its home position.

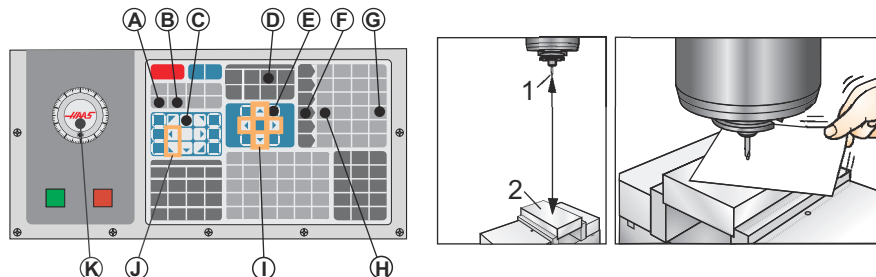

1. Load the tool in the spindle [1].
2. Press **[HANDLE JOG]** [A].
3. Press **[.1/100.]** [B] (The mill will move at a fast rate when the handle is turned).
4. Select between the X and Y axes [C] and handle jog [D] the tool near the center of the part.
5. Press **[+Z]** [E].
6. Handle jog [D] the Z Axis approximately 1" above the part.
7. Press **[.0001/.1]** [F] (The mill will move at a slow rate when the handle is turned).
8. Place a sheet of paper between the tool and the work piece. Carefully move the tool down to the top of the part, as close as possible, and still be able to move the paper.
9. Press **[OFFSET]** [G].
10. Press **[PAGE UP]** [H] until the page with "Coolant - Length - Radius at the top and scroll to tool #1.
11. Cursor [I] to Geometry for position #1.
12. Press **[TOOL OFFSET MEASURE]**[J].



**CAUTION:** *The next step will cause the spindle to move rapidly in the Z Axis.*

13. Press **[NEXT TOOL]** [K].
14. Repeat the offset process for each tool.

## 3.12.4 Additional Tooling Set-up

There are other tool set-up pages within the Current Commands.

1. Press [**CURRENT COMMANDS**] and then use [**PAGE UP**]/[**PAGE DOWN**] to scroll to these pages.
2. The first is the page with Tool Load at the top of the page. You can add a tool load limit. The control references these values and can be set to do a specific action should the limitations be reached. Refer to Setting 84 (page **359**) for more information on tool limit actions.
3. The second page is the Tool Life page. On this page there is a column called “Alarm”. The programmer can put a value in this column, causing the machine to stop once the tool has been used that amount of times.

## 3.13 Dry Run Operation

The Dry Run function is used to check a program quickly without actually cutting parts. To select Dry Run:

1. While in MEM or MDI mode, press [**DRY RUN**].  
When in Dry Run, all rapids and feeds are run at the speed selected with the jog speed buttons.
2. Dry Run can only be turned on or off when a program has completely finished or the [**RESET**] is pressed. Dry Run will still make all of the commanded XYZ moves and requested tool changes. The override keys can be used to adjust the Spindle speeds in Dry Run.



### NOTE:

*Graphics mode is just as useful and may be safer as it does not move the axes of the machine before the program is checked.*

## 3.14 Running Programs

Once a program is loaded on the machine and the offsets are set, to run the program:

1. Press [**CYCLE START**].
2. It is suggested that you run the program in Dry Run or Graphics mode before doing any cutting.

## 3.15 Run-Stop-Jog-Continue

This feature allows the operator to stop a running program, jog away from the part, and then resume program execution. To use the feature, do the following:

1. Press **[FEED HOLD]** to stop the running program.
2. Press **[X]**, **[Y]** or **[Z]** on the Alpha keyboard then press **[HANDLE JOG]**. The control stores the current X, Y, and Z positions.



**NOTE:**

*Axes other than X, Y, and Z cannot be jogged.*

3. The control displays the message *Jog Away*. Use the **[HANDLE JOG]** control, remote jog handle, **[+X]/[-X]**, **[+Y]/[-Y]**, **[+Z]/[-Z]**, or **[JOG LOCK]** to move the tool away from the part. Use control buttons such as **[AUX CLNT]** (TSC), or **[COOLANT]** to turn on/off the coolant (**[AUX CLNT]** requires that the door is closed). The spindle is controlled by pressing **[CW]**, **[CCW]**, **[STOP]**, **[TOOL RELEASE]**. If necessary, tool inserts can be changed.



**CAUTION:**

*When the program is continued, the old offsets are used for the return position. Therefore, it is unsafe and not recommended to change tools and offsets when the program is interrupted.*

4. Jog to a position as close as possible to the stored position, or to a position where there is an unobstructed rapid path back to the stored position.
5. Return to the previous mode by pressing **[MEMORY]** or **[MDI/DNC]**. The control continues only if the mode that was in effect when the machine stopped is re-entered.
6. Press **[CYCLE START]**. The control displays the message *Jog Return* and rapids X and Y at 5% to the position where **[FEED HOLD]** was pressed, then returns the Z-Axis. If **[FEED HOLD]** is pressed during this motion, the mill axes motion pauses and displays the message *Jog Return Hold*. Pressing **[CYCLE START]** causes the control to resume the Jog Return motion. When the motion is completed, the control again goes into a feed hold state.



**CAUTION:**

*The control does not follow the path used to jog away.*



7. Press [**CYCLE START**] again and the program resumes normal operation.

**CAUTION:**

*If Setting 36 is ON, the control scans the program to make sure the machine is in the correct state (tools, offsets, G- and M-codes, etc.) to safely continue the program. If Setting 36 is OFF, the control does not scan the program before restart. This can save time, but it could cause a crash in an unproven program.*

## 3.16 Axis Overload Timer

When a spindle or an axes current load is 180% load, a timer starts and displays in the **POSITION** pane. The timer starts at 1.5 minutes and counts down to zero. An axis overload alarm *SERVO OVERLOAD* displays when the time has expired to zero.

## 3.17 More Information Online

For updated and supplemental information, including tips, tricks, maintenance procedures, and more, go to [www.HaasCNC.com](http://www.HaasCNC.com) and select the **Resource Center**.



# Chapter 4: Programming

## 4.1 Numbered Programs

To create a new program:

1. Press **[LIST PROGRAM]** to enter the program display and the list of programs mode.
2. Enter a program number (Onnnnn) and press **[SELECT PROGRAM]** or **[ENTER]**.



**NOTE:**

*Do not use O09XXX numbers when you create new programs. Macro programs often use numbers in this block, and overwriting them may cause machine functions to malfunction or stop working.*

If the program exists, the control sets it as the active program (refer to page 77 for more information on the active program). If it does not yet exist, the control creates it and sets it as the active program.

3. Press **[EDIT]** to work with the new program. A new program has only the program name and an end-of-block character (semicolon).

## 4.2 Program Editors

The Haas control features (3) different program editors: The MDI Editor, the Advanced Editor, and the FNC Editor.

### 4.2.1 Basic Program Editing

This section describes the basic program editing controls. For information on more advanced program editing functions, refer to page 115.

F4.1: Edit Program Screen Example

The screenshot shows a window titled "EDIT: EDIT" with "EDITOR" in the top right corner. Below the title bar is a black header with the text "ACTIVE PROGRAM - 099997". The main area contains the following code:

```

099997 ;
(HAAS VQC Mill, English, Inch, v1.4A) ;
(11/14/01) ;
;
N100 ;
(CATEGORY) ;
(NAME G73 HIGH SPEED PECK DRILLING) ;
;
N101 ;
(TEMPLATE) ;
(NAME G73 High Speed Peck Drill Using Q, 1-H
ole) ;

```

1. You write or make changes to programs in an active **EDIT:EDIT** or **EDIT:MDI** window.
  - a. To edit a program in MDI, press **[MDI/DNC]**.
  - b. To edit a numbered program, select it, then press **[EDIT]**. Refer to page 77 to learn how to select a program.
2. To highlight code to edit:
  - a. Use the cursor arrow keys or the **[HANDLE JOG]** control to highlight a single piece of code. That code appears with white text on a black background.
  - b. If you want to highlight an entire block or multiple blocks of code, press **[F2]** at the program block where you want to start, then use the cursor arrow keys or the **[HANDLE JOG]** control to move the cursor arrow (>) to the first or last line you want to highlight. Press **[ENTER]** or **[F2]** to highlight all of that code.
3. To add code to the program:
  - a. Highlight the code that your new code will go in front of.
  - b. Type the code that you want to add to the program.
  - c. Press **[INSERT]**. Your new code appears in front of the block you highlighted.
4. To replace code, highlight the desired portion of the program using the arrow keys or the **[HANDLE JOG]** control, enter the replacement code, and press **[ALTER]**.
  - a. Highlight the code you want to replace.
  - b. Type the code you want to replace the highlighted code with.
  - c. Press **[ALTER]**. Your new code takes the place of the code you highlighted.
5. To remove characters or commands, highlight the text and press **[DELETE]**.
  - a. Highlight the text you want to delete.
  - b. Press **[DELETE]**. The code you highlighted is removed from the program.

**NOTE:**

*The control saves programs in **MEMORY** as you enter each line. To save programs in **USB, HD, or Net Share**, refer to the **Haas Editor (FNC)** section on page **124**.*

6. Press **[UNDO]** to reverse up to the last (9) changes.

## 4.2.2 Background Edit

Background Edit allows you to edit a program while another program runs.

1. Press **[EDIT]** until the background edit pane (Inactive Program) on the right side of the screen is active.
2. Press **[SELECT PROGRAM]** to select a program to background edit (the program must be in Memory) from the list.
3. Press **[ENTER]** to begin background editing.
4. To select a different program to background edit, press **[SELECT PROGRAM]** from the background edit pane and choose a new program from the list.
5. All of the changes made during Background Edit will not affect the running program, or its subprograms. The changes will go into effect the next time the program is run. To exit background edit and return to the running program, press **[PROGRAM]**.
6. **[CYCLE START]** may not be used while in Background Edit. If the program contains a programmed stop (M00 or M30), exit Background Edit (press **[PROGRAM]**) and then press **[CYCLE START]** to resume the program.

**NOTE:**

*All keyboard data is diverted to the Background Editor, when a M109 command is active and Background Edit is entered, Once an edit is complete (by pressing **[PROGRAM]**) keyboard input will return to the M109 in the running program.*

## 4.2.3 Manual Data Input (MDI)

Manual Data Input (MDI) lets you command automatic CNC moves without a formal program. Your input stays on the MDI input page until you delete it.

### F4.2: MDI Input Page Example



```
MDI
G97 S1000 M03 ;
G00 X2. Z0.1 ;
X1.78 ;
X1.76 ;
X1.75 ;
```

1. Press **[MDI/DNC]** to enter **MDI** mode.
2. Type program commands in the window. Press **[CYCLE START]** to execute the commands.
3. If you want to save the program you created in MDI as a numbered program:
  - a. Press **[HOME]** to place the cursor at the beginning of the program.
  - b. Type a new program number. Program numbers must follow standard program number format (Onnnnn).
  - c. Press **[ALTER]**.

The control saves your program to memory and clears the MDI input page. You can find the new program in the **MEMORY** tab in the Device Manager menu (press **[LIST PROGRAM]**).
4. Press **[ERASE PROGRAM]** to delete everything from the MDI input page.

## 4.2.4 Advanced Editor

The advanced editor allows you to edit programs using popup menus.

**F4.3:** Advanced Editor Display: [1] Active Program Pane, [2] Pop-up menus, [3] Inactive Program Pane, [4] Clipboard, [5] Context-sensitive help messages.

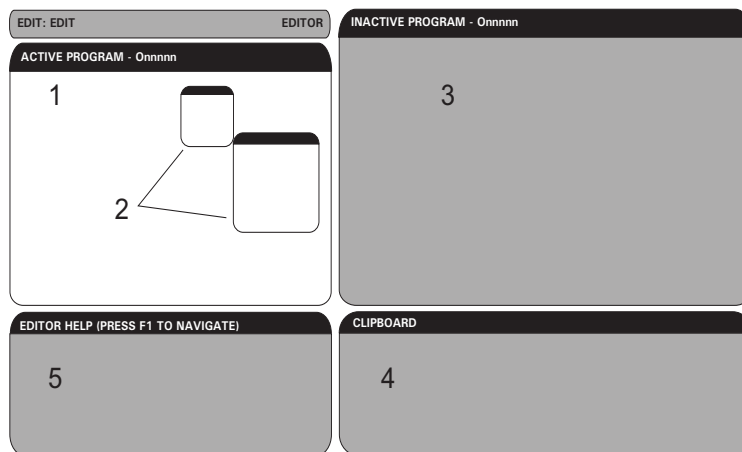

1. Press **[EDIT]** to enter edit mode.
2. Two editing panes are available; an active program pane and an inactive program pane. Press **[EDIT]** to switch between the two panes.
3. To edit a program, type the program name (Onnnnn) from the active program pane, and then press **[SELECT PROGRAM]**  
The program opens in the active window with an asterisk (\*) in front of the name.
4. Press **[F4]** to open another copy of that program in the inactive program pane if there is not a program there already.
5. You can also select a different program for the inactive program pane. Press **[SELECT PROGRAM]** from the inactive program pane and select the program from the list.
6. Press **[F4]** to exchange the programs between the two panes (make the active program inactive and vice versa).
7. Use the jog handle or cursor keys to scroll through the program code.
8. Press **[F1]** to access the pop-up menu.
9. Use the **[LEFT]** and **[RIGHT]** cursor arrows to select from the topic menu (HELP, MODIFY, SEARCH, EDIT, PROGRAM), and use the **[UP]** and **[DOWN]** cursor arrows or the jog handle to select a function.
10. Press **[ENTER]** to execute a command from the menu.



**NOTE:**

*A context-sensitive help pane in the lower left provides information on the currently selected function.*

11. Use **[PAGE UP]**/**[PAGE DOWN]** to scroll through the help message. This message also lists hot keys that you can use for some functions.

## The Advanced Editor Pop-up Menu

The pop-up menu provides easy access to editor functions in 5 categories: **HELP**, **MODIFY**, **SEARCH**, **EDIT**, and **PROGRAM**. This section describes each category and the options available when you select it.

Press F1 to access the menu. Use the **[LEFT]** and **[RIGHT]** cursor arrows to select from the list of categories, and the **[UP]** and **[DOWN]** cursor arrows to select an command in the category list. Press **[ENTER]** to execute the command.

## The Program Menu

The program menu provides options for program creation, deletion, naming, and duplicating, as described in the basic program editing section.

**F4.4:** The Advanced Editor Program Menu

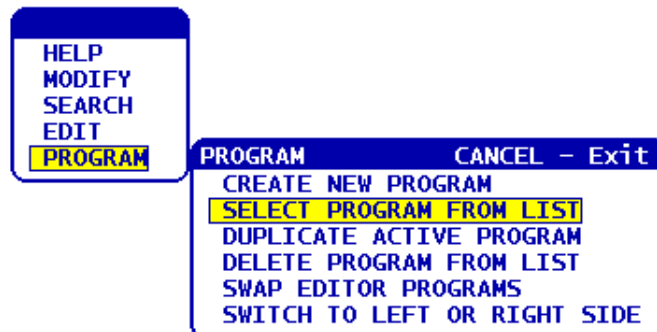



---

## Create New Program

1. Select the **CREATE NEW PROGRAM** command from the **PROGRAM** pop-up menu category.
2. Type a program name (Onnnnn) that is not already in the program directory.
3. Press **[ENTER]** to create the program.

## Select Program From List

1. Press **[F1]**.
2. Select the **SELECT PROGRAM FROM LIST** command from the **PROGRAM** pop-up menu category.  
When you select this menu item, a list appears of programs in the control memory.
3. Highlight the program you want to select.
4. Press **[ENTER]**.

## Duplicate Active Program

1. Select the **DUPLICATE ACTIVE PROGRAM** command from the **PROGRAM** pop-up menu category.
2. At the prompt, type a new program number (Onnnnn) and press **[ENTER]** to create the program.

## Delete Program From List

1. Select the **DELETE PROGRAM FROM LIST** command from the **PROGRAM** pop-up menu category.  
When you select this menu item, a list appears of programs in the control memory.
2. Highlight a program, or highlight **ALL** to select all programs in memory for deletion.
3. Press **[ENTER]** to delete the selected programs.

## Swap Editor Programs

This menu option puts the active program in the inactive program pane and the inactive program in the active program pane.

1. Select the **SWAP EDITOR PROGRAMS** command from the **PROGRAM** pop-up menu category.
2. Press **[ENTER]** to swap the programs.

## Switch to Left or Right Side

This switches edit control between the active and inactive program. Inactive and active programs remain in their respective panes.

1. Select the **SWITCH TO LEFT OR RIGHT SIDE** command from the **PROGRAM** pop-up menu.
2. Press **[ENTER]** to switch between the active and inactive programs.

## The Edit Menu

The edit menu provides advanced edit options over the quick-edit functions described in the basic program editing section.

**F4.5:** Advanced Edit Pop-up Menu

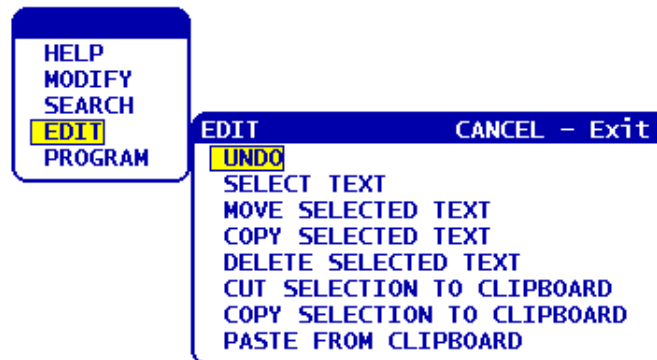

## Undo

Reverses the last edit operation, up to the last 9 edit operations.

1. Press **[F1]**. Select the **UNDO** command from the **EDIT** pop-up menu category.
2. Press **[ENTER]** to undo the last edit operation. You can also use the hot key - **[UNDO]**.

## Select Text

This menu item will select lines of program code:

1. Select the **SELECT TEXT** command from the **EDIT** pop-up menu category.
2. Press **[ENTER]** or use the hot key - **[F2]** to set the start point of the text selection.
3. Use the cursor keys, **[HOME]**, **[END]**, **[PAGE UP]** / **[PAGE DOWN]**, or the jog handle to scroll to the last line of code to be selected.
4. Press **[F2]** or **[ENTER]**.  
The selected text is highlighted, and you can now move, copy, or delete it.
5. To deselect the block, press **[UNDO]**.

## Move Selected Text

After you select a section of text, you can use this menu command to move it to another part of the program.

1. Move the cursor (>) to the program line where you want to move the selected text.
2. Select the **MOVE SELECTED TEXT** command from the **EDIT** pop-up menu category.
3. Press **[ENTER]** to move the selected text to the point after the cursor (>).

## Copy Selected Text

After you select a section of text, you can use this menu command to copy it to another location in your program.

1. Move the cursor (>) to the program line where you want to copy the selected text.
2. Select the **COPY SELECTED TEXT** command from the **EDIT** pop-up menu category.
3. Press **[F2]** or **[ENTER]** to copy the selected text to the point after the cursor (>).
4. Hot Key - Select the text, position the cursor, and press **[ENTER]**.

## Delete Selected Text

To delete selected text:

1. Press **[F1]**. Select the **DELETE SELECTED TEXT** command from the **EDIT** pop-up menu category.
2. Press **[F2]** or **[ENTER]** to delete the selected text to the point after the cursor (>).  
If no block is selected, the currently highlighted item is deleted.

## Cut Selection to Clipboard

After you select a section of text, you can use this menu command to remove it from the program and place it in the clipboard.

1. Select the **CUT SELECTION TO CLIPBOARD** command from the **EDIT** pop-up menu category.
2. Press **[F2]** or **[ENTER]** to cut the selected text.  
The selected text is removed from the current program and placed in the clipboard. This replaces any content in the clipboard.

### Copy Selection To Clipboard

After you select a section of text, you can use this menu command to place a copy of the text in the clipboard.

1. Select the **COPY SELECTION TO CLIPBOARD** command from the **EDIT** pop-up menu category.
2. Press **[ENTER]** to copy the selected text to the clipboard.  
The selected text is placed in the clipboard. This replaces any content in the clipboard. The text is not removed from the program.

### Paste From Clipboard

To copy the contents of the clipboard to the line after the cursor position:

1. Move the cursor (>) to the program line where you want to insert the clipboard text.
2. Select the **PASTE FROM CLIPBOARD** command from the **EDIT** pop-up menu category.
3. Press **[ENTER]** to insert the clipboard text at the point after the cursor (>).

## The Search Menu

The search menu provides advanced search options over the quick-search function described in the basic program editing section.

**F4.6:** Advanced Search Popup

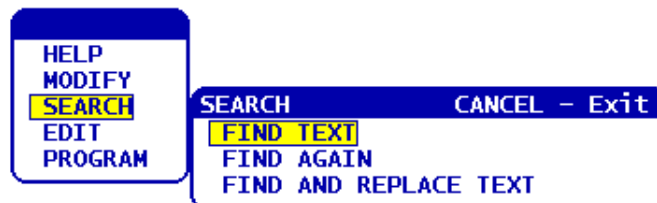

## Find Text

To search for text or program code in the current program:

1. Select the **FIND TEXT** command from the **SEARCH** pop-up menu category.
2. Type the text you want to find.
3. Press **[ENTER]**.
4. Press **[F]** to search for your text below the cursor position. Press **[B]** to search above the cursor position.

The control searches your program in the direction you specified, then it highlights the first occurrence of your search term found. If your search returns no results, the message *NOT FOUND* appears in the system status bar.

## Find Again

This menu option allows you to quickly repeat your last **FIND** command. This is a quick way to continue searching the program for more occurrences of a search term.

1. Select the **FIND AGAIN** command in the **SEARCH** pop-up menu category.
2. Press **[ENTER]**.  
The control searches again, from the current cursor position, for the last search term you used, in the same direction that you specified.

## Find And Replace Text

This command searches the current program for specific text or program, and replaces each occurrence (or all) with different text.

1. Press **[F1]**. Select the **FIND AND REPLACE TEXT** command in the **SEARCH** pop-up menu category.
2. Type your search term.
3. Press **[ENTER]**.
4. Type the text with which you want to replace the search term.
5. Press **[ENTER]**.
6. Press **[F]** to search for the text below the cursor position. Press **[B]** to search above the cursor position.
7. When the control finds each occurrence of the search term, it gives the prompt *Replace (Yes/No/All/Cancel) ?*. Type the first letter of your choice to continue.

If you choose **Yes** or **No**, the editor will execute your choice and move to the next occurrence of the search term.

Choose **All** to automatically replace all occurrences of the search term.

Choose **Cancel** to back out of the function without making changes (text already replaced will remain so if you choose this option).

## The Modify Menu

The modify menu category contains functions for quick changes to the entire program.

**F4.7:** Advanced Modify Popup

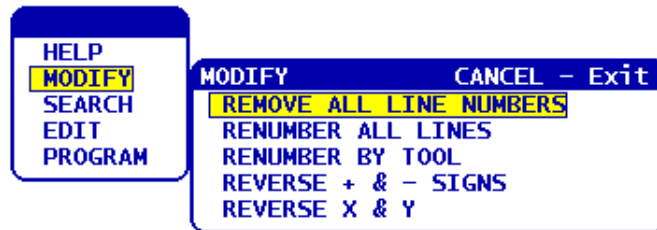

### Remove All Line Numbers

This command automatically removes all unreferenced line numbers from the edited program. If you have selected a group of lines (refer to page **119**), this command affects only those lines.

1. Select the **REMOVE ALL LINE NUMBERS** command from the **MODIFY** pop-up menu category.
2. Press **[ENTER]**.

### Renumber All Lines

This command numbers all of the blocks in the program. If you have selected a group of lines (refer to page **119**), this command affects only those lines.

1. Select the **RENUMBER ALL LINES** from the **MODIFY** pop-up menu category.
2. Enter the starting N-code number.
3. Press **[ENTER]**.

4. Enter the N-code increment.
5. Press **[ENTER]**.

## Renumber By Tool

This command searches the program for T (tool) codes, highlights all the program code up to the next T-code, and renumbers the N-code (line numbers) in the program code.

1. Select the **RENUMBER BY TOOL** command from the **MODIFY** pop-up menu category.
2. For each T-code found, answer the prompt *Renumber (Yes/No/All/Cancel)?* If you answer **[A]**, the process will continue as if you pressed Y for each T-code. The prompt will not appear again during this operation.
3. Enter the starting N-code number.
4. Press **[ENTER]**.
5. Enter the N-code increment.
6. Press **[ENTER]**.
7. Answer *Resolve outside references (Y/N)?* with **[Y]** to change outside code (like GOTO line numbers) with the proper number, or **[N]** to ignore outside references.

## Reverse + and - Signs

This menu item reverses the signs of the numeric values in a program. Be cautious with this function if the program contains a G10 or G92 (refer to the G-code section for a description).

1. Select the **REVERSE + & - SIGNS** command from the **MODIFY** pop-up menu category.
2. Enter the address code(s) you want to change.



### NOTE:

*D, F, G, H, L, M, N, O, P, Q, S, and T address codes are not allowed.*

3. Press **[ENTER]**.

## Reverse X and Y

This feature will change X address codes in the program to Y address codes, and Y address codes to X address codes.

1. Select the **REVERSE X & Y** command from the **MODIFY** pop-up menu category.
2. Press **[ENTER]**.

### 4.2.5 The FNC Editor

The FNC Editor provides the same familiar functions as the Advanced Editor, along with new features to enhance program development on the control, including multiple-document viewing and editing.

In general, you use the Advanced Editor with programs in MEM, while you use the FNC Editor with programs on drives other than MEM (HDD, USB, Net Share). Refer to the Basic Editing (page 111) and Advanced Editor (page 115) sections for information on those editors.

To save a program after editing with the FNC Editor:

1. Press **[SEND]** when prompted.
2. Wait for the program to finish writing to the drive.

### Loading a Program (FNC)

To load a program:

1. Press **[LIST PROGRAM]**.
2. Highlight a program in the **USB**, **HARD DRIVE**, or **NET SHARE** tab of the **LIST PROGRAM** window.
3. Press **[SELECT PROGRAM]** to make it the active program (in the FNC Editor, programs open in FNC, but are editable).
4. With the program loaded, press **[EDIT]** to shift focus to the program edit pane.

The initial display mode shows the active program on the left, and the program list on the right.



## F4.8: Edit: Edit Display

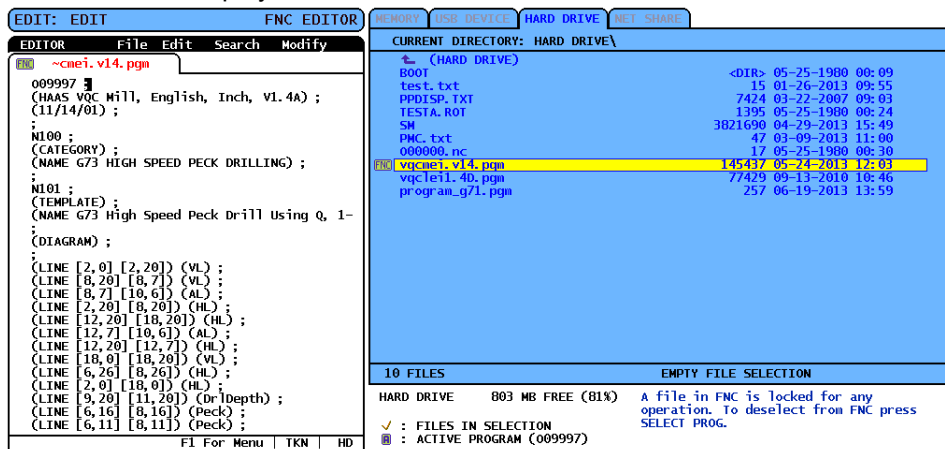

## Menu Navigation (FNC)

To access the menu.

1. Press **[F1]**.
2. Use the left and right cursor arrow keys or jog handle to move between the menu categories, and use the **[UP]** and **[DOWN]** cursor arrows to highlight an option within a category.
3. Press **[ENTER]** to make a menu selection.

## Display Modes (FNC)

Three display modes are available. Switch between display modes:

1. Press **[F1]** for the popup File menu.
2. Use the Change View command.
3. Press **[ENTER]**.
4. List displays the current FNC program alongside the tabbed LIST PROG menu.
5. Main displays one program at a time in a tabbed pane (switch between tabs using the Swap Programs command in the File menu or by pressing **[F4]**).
6. Split displays the current FNC program on the left and the currently open programs in a tabbed pane on the right. Toggle the active pane using the Switch to Left or Right Side in the File menu or by pressing **[EDIT]**. When the tabbed pane is active, switch between tabs using the Swap Programs command in the **[F1]** popup File menu or by pressing **[F4]**.

## Display Footer (FNC)

The footer section of the program display shows system messages and other information about the program and current modes. The footer is available in all three display modes.

### F4.9: Footer Section of Program Display

```

      (CALLS 1ST & 2ND OP. CHAMFER PGM) ;
      (-----) ;
      (WORK OFFSET #54 UPPER RIGHT) ;
      (CORNER OF PART.) ;
      (WORK OFFSET #55 IS THE LARGE) ;
      (DIAMETER THAT IS X5.831 FROM ZERO) ;
      (IN X-AXIS. AND IS Y-.9157 FROM) ;
      (ZERO IN Y-AXIS.) ;
      (-----) ;
      ;

```

F1 For Menu	TKN	USB
-------------	-----	-----

The first field displays prompts (in red text) and other system messages. For example, if a program has been changed and needs to be saved, the message *PRESS SEND TO SAVE* appears in this field.

The next field displays the current jog handle scroll mode. TKN indicates that the editor is currently scrolling token by token through the program. Continuously jogging through the program will change the scroll mode to LNE, and the cursor will scroll line by line. Continuing to jog through the program will change the scroll mode to PGE, scrolling a page at a time.

The last field indicates which device (HD, USB, NET) on which the active program is saved. This display will be blank when the program is not saved or when the clipboard is being edited.

## Opening Multiple Programs (FNC)

You can open up to three programs simultaneously in FNC Editor. To open an existing program while another program is open in FNC Editor:

1. Press **[F1]** to access the menu.
2. Under the File category, select Open Existing File.
3. The program list is displayed. Select the device tab where the program resides, highlight the program with the up/down arrow keys or the jog handle, and press **[SELECT PROGRAM]**. The display will switch to split mode with the FNC program on the left and the newly opened program and the FNC program on the right in a tabbed pane. To change the program in the tabbed pane, select the Swap Programs command in the File menu or press **[F4]** while the tabbed pane is active.

## Display Line Numbers (FNC)

To display line numbers independent of the program text:

1. Select the **Show Line Numbers** command from the File menu to display them.

**NOTE:**

*These are not the same as Nxx line numbers; they are only for reference when viewing the program.*

2. To hide the line numbers, reselect the option in the File menu.

## File Menu (FNC)

To access the File menu:

1. When in FNC EDITOR mode, press **[F1]**.
2. Cursor to the File menu.

### F4.10: File Menu

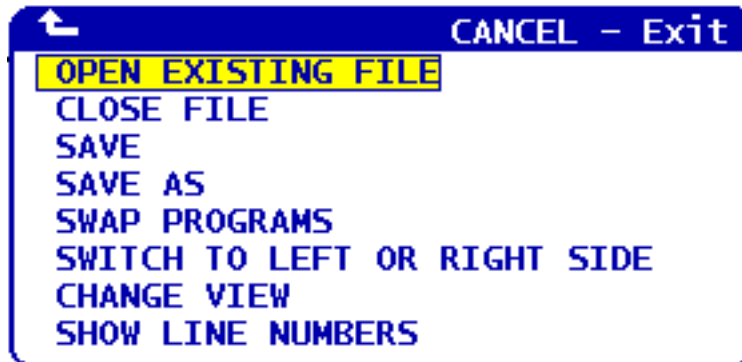

### Open Existing File

When in FNC EDITOR mode,

1. Press **[F1]**.
2. Cursor to the File menu and select Open Existing File.
3. Check mark a file to open and press **[SELECT PROGRAM]**.

Opens a file from the LIST PROGRAM menu in a new tab.

## Close File

When in FNC EDITOR mode,

1. Press **[F1]**.
2. Cursor to the File menu and select Close File.

Closes the current active file. If the file has been changed, the control will prompt to save before closing.

## Save



### **NOTE:**

*Programs are not saved automatically. If power is lost or turned off before saving changes, those changes will be lost. Be sure to save your program frequently while editing.*

Hot Key: **[SEND]** (after a change is made)

1. Press **[F1]**.
2. Cursor to the File menu and select **Save**.

Saves the current active file under the same filename.

## Save As

When in FNC EDITOR mode,

1. Press **[F1]**.
2. Cursor to the File menu and select Save As.

Saves the current active file under a new filename. Follow prompts for naming the file. Displays in new tab.

## Swap Programs

When in FNC EDITOR mode and in a tabbed stack of programs, use Hot Key: **[F4]** or,

1. Press **[F1]**.
2. Cursor to the File menu and select Swap Programs.

Brings the next program in a tabbed pane to the top of the tab stack.

## Switch to Left or Right Side

To change the active program window (the currently active window has a white background) in FNC EDITOR mode and in a tabbed stack of programs:

1. Press **[F1]** or use Hot Key: **[EDIT]**.
2. If you pressed **[F1]**, cursor to the File menu and select Switch to Left or Right Side.

## Change View

When in FNC EDITOR mode, use Hot Key: **[PROGRAM]** or,

1. Press **[F1]**.
2. Cursor to the File menu and select Change View.

Switches between List, Main, and Split view modes.

## Show Line Numbers

When in FNC EDITOR mode,

1. Press **[F1]**.
2. Cursor to the File menu and select Show Line Numbers.

Displays reference-only line numbers independent of program text. They are never saved as part of the program like Nxx numbers would be. Select the option again to hide the line numbers.

## Edit Menu (FNC)

To access the Edit menu:

1. When in FNC EDITOR mode, press **[F1]**.
2. Cursor to the Edit menu.

F4.11: Edit Menu

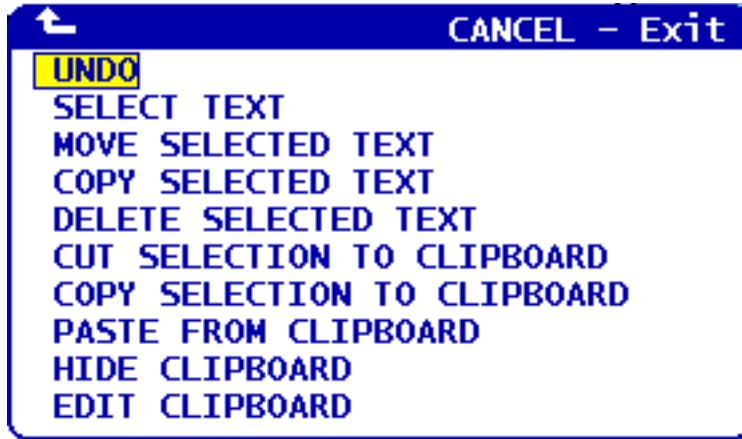

## Undo

To reverse changes made to the active program in FNC EDITOR mode:



**NOTE:**

*Block and global functions cannot be undone.*

1. Press **[F1]**.
2. Select the **EDIT** menu, then select **UNDO**.

## Select Text

To highlight a block of text in FNC EDITOR mode:

1. Before choosing this menu option or using the hot key **[F2]**, position the cursor at the first line of the block you wish to select.
2. Press **[F2]** (hot key) or press **[F1]**.
3. If you used the hot key, skip to step 4. Otherwise, cursor to the **EDIT** menu and pick **SELECT TEXT**.
4. Use the cursor arrows or jog handle to define the selection area.
5. Press **[ENTER]** or **[F2]** to highlight the block.

## Move/Copy/Delete Selected Text

To remove selected text from its current location and place it after the cursor position (Hot Key: **[ALTER]**), to place selected text after the cursor position without deleting it from its current location (Hot Key: **[INSERT]**), or to remove the selected text from the program (Hot Key: **[DELETE]**) in FNC EDITOR mode:

1. Before choosing this menu option or using Hot Keys: **[ALTER]**, **[INSERT]**, or **[DELETE]**, position the cursor at the line above where you wish to paste selected text. **[DELETE]** removes the selected text and closes up the program listing.
2. If you did not use the hot keys, press **[F1]**.
3. Cursor to the Edit menu and select Move Selected Text, Copy Selected Text, or Delete Selected Text.

## Cut/Copy Selection to Clipboard

To remove the selected text from the current program and move it to the clipboard or to place the selected text in the clipboard without removing it from the program in FNC EDITOR mode:



### NOTE:

*The clipboard is a persistent storage location for program code; text copied to the clipboard is available until overwritten, even after power cycles.*

1. Press **[F1]**.
2. Cursor to the Edit menu and select Cut Selection to Clipboard or Copy Selection to Clipboard.

## Paste from Clipboard

To place the clipboard contents after the cursor location in FNC EDITOR mode:



### NOTE:

*Does not delete the clipboard contents.*

1. Before choosing this menu option, position the cursor at the line you want the clipboard contents to follow.
2. Press **[F1]**.
3. Cursor to the Edit menu and select Paste from Clipboard.

## Hide/Show Clipboard

To hide the clipboard to view the position and timers & counters displays in its place or to restore the clipboard display in FNC EDITOR mode:

1. Press **[F1]**.
2. Cursor to the Edit menu and select Show Clipboard. To hide the clipboard, repeat this with the menu changed to Hide Clipboard.

## Edit Clipboard

To make adjustments to the clipboard contents in FNC EDITOR mode:



**NOTE:**

*The FNC Editor clipboard is separate from the Advanced Editor clipboard. Edits made in Haas Editor cannot be pasted into Advanced Editor.*

1. Press **[F1]**.
2. Cursor to the Edit menu and select Edit Clipboard.
3. When finished, press **[F1]**, cursor to the Edit menu, and select Close Clipboard.

## Search Menu (FNC)

To access the Search menu:

1. When in FNC EDITOR mode, press **[F1]**.
2. Cursor to the Search menu.

**F4.12:** Search Menu

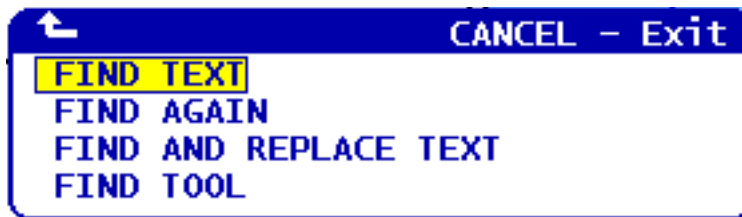



## Find Text

To define a search term, search direction, and to locate the first occurrence of the search term in the direction indicated in FNC EDITOR mode:

1. Press **[F1]**.
2. Cursor to the Search menu and select Find Text.
3. Enter text item to locate.
4. Enter search direction. When choosing a search direction, press F to search for the term below the cursor position, and press B to search above the cursor position.

## Find Again

To locate the next occurrence of the search term in FNC EDITOR mode:

1. Press **[F1]**.
2. Cursor to the Search menu and select Find Again.
3. Select this function immediately after a “Find Text” search. Repeat to continue to the next occurrence.

## Find and Replace Text

To define a search term, a term to replace it with, the search direction, and choose Yes/No/All/Cancel in FNC EDITOR mode:

1. Press **[F1]**.
2. Cursor to the Search menu and select Find and Replace Text.
3. Enter text to locate.
4. Enter replacement text.
5. Enter search direction. When choosing a search direction, press F to search for the term below the cursor position, and press B to search above the cursor position.
6. When the first occurrence of the search term is found, the control will prompt *Replace (Yes/No/All/Cancel)?*. Type the first letter of your choice to continue. If you choose **Yes** or **No**, the editor will execute your choice and move to the next occurrence of the search term. Choose **A11** to automatically replace all occurrences of the search term. Choose **Cancel** to back out of the function without making changes (text already replaced will remain so if you choose this option).

## Find Tool

To search the program for tool numbers in FNC EDITOR mode:

1. Press **[F1]**.
2. Cursor to the Search menu and select Find Tool.
3. Select it again to locate the next tool number.

## Modify Menu (FNC)

To access the Modify menu:

1. When in FNC EDITOR mode, press **[F1]**.
2. Cursor to the Modify menu.

**F4.13:** Modify Menu

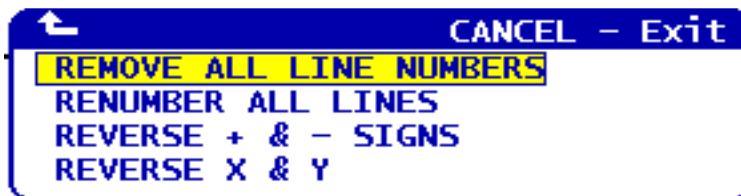

### Remove All Line Numbers

To remove all Nxx line numbers from the program in FNC EDITOR mode:

1. Press **[F1]**.
2. Cursor to the Modify menu and select Remove All Line Numbers.

### Renumber All Lines

To renumber all program lines with Nxx codes in FNC EDITOR mode:

1. Press **[F1]**.
2. Cursor to the Modify menu and select Renumber All Lines.
3. Choose a starting number.
4. Choose a line number increment.

## Reverse + and - Signs

To change all positive values to negative and vice versa in FNC EDITOR mode:

1. Press **[F1]**.
2. Cursor to the Modify menu and select Reverse + and - Signs.
3. Enter address code(s) to change. Letter addresses not allowed are D, F, G, H, L, M, N, O, P, Q, S, and T.

## Reverse X and Y

To change all X values to Y values and vice versa in FNC EDITOR mode:

1. Press **[F1]**.
2. Cursor to the Modify menu and select Reverse X and Y.

## 4.3 Fadal Program Converter

The Fadal Program Converter quickly converts Fadal code into a Haas program.

### F4.14: Load FADAL Popup

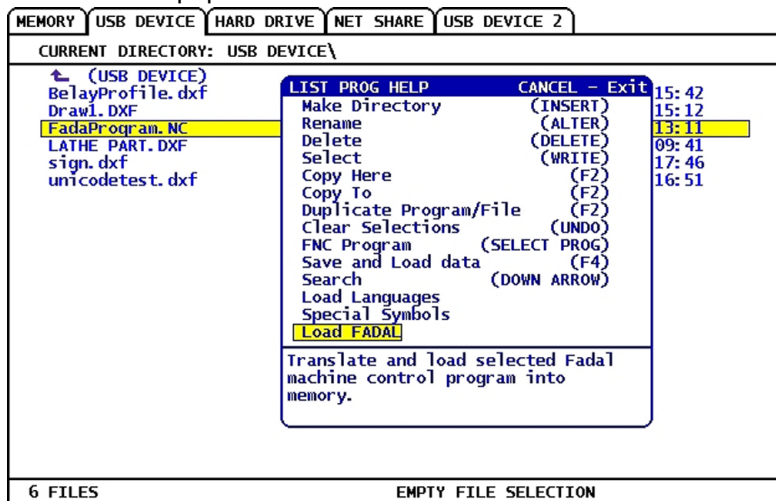

TIP: You can quickly locate unconverted lines using the search function in edit mode. With the converted program in the active pane (press **[PROGRAM]** to change the active pane), press **[F1]** or **[HELP]** and select **Search** from the pop-up menu. Use M1.99 as the search term.

### F4.15: Fadal Conversion Complete

MEM	000003	N0000000	MEMORY	USB DEVICE	HARD DRIVE	NET SHARE	USB DEVICE 2
000003 (Converted Fadal program) ;			CURRENT DIRECTORY: USB DEVICE\				
N10 (N1) (03) (FACE TABLE) ;			← (USB DEVICE)				
N20 (N2) (PART NAME) ;			BelayProfile.dxf 48761 07-29-2009 15:42				
N30 (N3) (X0 Y0 I5) ;			Draw1.DXF 1194268 03-31-1999 15:12				
N40 (N4) (Z0 IS TOP OF THE PART) ;			FadaProgram.NC 553 05-02-2009 13:11				
N50 (N5) (*****TOOL_LIST*****) ;			FadaProgram.OUT 931 08-05-2009 09:44				
N60 (N6) (T1=3 " SONNET FACE MILL3. DIA)			LATHE PART.DXF 957490 06-01-2006 09:41				
;			sign.dxf 157120 11-16-2007 17:46				
N70 (N7) (*****END OF TOOL LIST*****)			unicodetest.dxf 13173 07-28-2009 16:51				
;							
N80 (N8) G90 G80 G40 G17 G00 ;							
N90 (N9) T1 M06 (T1=3 " SONNET FACE MILL							
3. DIA) ;							
N100 (N10) G154 P14 G00 X10.5 Y-7.5							
S4000 M03 ;							
N110 (N11) G43 H01 Z1. M08 ;							
N120 (N12) Z0.1 ;							
N130 (N13) G01 Z0. F30. ;							
N140 (N14) X-10.5 ;							
N150 (N15) Y7.5 ;							
N160 (N16) X10.5 ;							
N170 (N17) Y-7.5 ;							
N180 (N18) XB.1 Y-5.1 ;							
N190 (N19) X-8.1 ;							
N200 (N20) Y5.1 ;							
N210 (N21) XB.1 ;							
N220 (N22) Y-5.1 ;							
N230 (N23) X5.7 Y-2.7 ;							
N240 (N24) X-5.7 ;							
N250 (N25) Y2.7 ;							
N260 (N26) X5.7 ;							
			7 FILES EMPTY FILE SELECTION				
			Use CURSOR keys to navigate listing and CANCEL to go back to devices. Press HELP for Help listing.				
			✓ : FILES IN SELECTION				
			Ⓜ : ACTIVE PROGRAM (000003)				

### F4.16: Fadal Conversion Errors

MEM	008686	N00000210	USER GENERATED ALARM
M199 (NOT SUPPORTED: P.01) ;			NOT SUPPORTED: P.01
N370 (N934) M97 L1 P9330 ;			
N380 (N936) G80 ;			
N390 (N938) M05 ;			
M09 ;			
N400 (N940) G90 G43 H00 Z0. ;			
N410 (N942) M01 ;			
N420 (N944) (* 1/4-20 TAPRH TOOL - 4 DIA. OF			
F. - 4 LEN. - 4 DIA - 0.25 ) ;			
N430 (N946) T4 M06 ;			

1. Press **[LIST PROGRAM]** to access the converter.
2. Highlight the Fadal program.
3. Press **[F1]**.
4. Select **Load FADAL** from the pop-up menu.

The converted program is loaded into memory. A copy of the converted program is also saved to I/O device selected, with an ".out" extension. The program will contain *Converted Fadal Program* at the top to confirm that it is a converted program. Any lines that could not be converted are commented out with an *M199*, which will give a User Generated Alarm when the program is run. Review these lines and edit them for Haas compatibility.

## 4.4 Program Optimizer

This feature allows you to override spindle speed, axis feed, and coolant positions (for a mill) in a program, as the program runs. Once the program is finished, the Program Optimizer highlights the program blocks that you changed and allows you to make the change permanent or revert to the original values.

You can type comments into the input line and press **[ENTER]** to save your input as program notes. You can see the Program Optimizer during a program run by pressing **[F4]**.

### 4.4.1 Program Optimizer Operation

To go to the Program Optimizer screen:

1. At the end of a program run, press **[MEMORY]**.
2. Press **[F4]**.
3. Use the right/left and up/down arrows, **[PAGE UP]/[PAGE DOWN]** and **[HOME]/[END]** to scroll through **Overrides** and **Notes** columns.
4. On the column topic to edit, press **[ENTER]**.

A pop-up window appears with selections for that column. The programmer can make a number of changes using the commands in the menu.

**F4.17:** Program Optimizer Screen: Feed Override Popup Example (Mill Screen Shown)

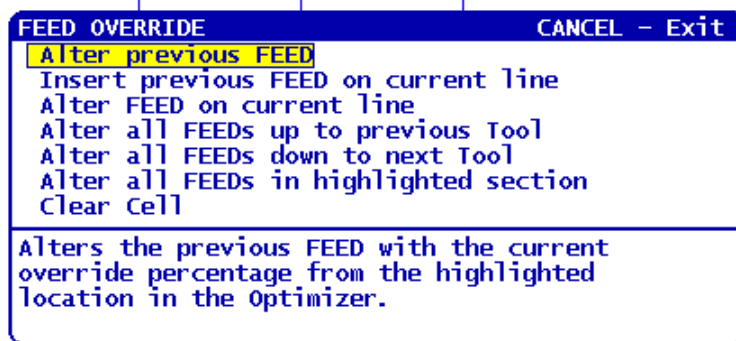

5. In addition, a section of code can be highlighted (cursor to start of selection, press **[F2,]** scroll to end of selection and press **[F2]**). Go back to the Program Optimizer (press **[EDIT]**) and press **[ENTER]**, this will allow you to alter all the feeds or speeds in the highlighted section.

## 4.5 DXF File Importer

This feature can quickly build a CNC G code program from a .dxf file. This is accomplished with three steps:

### F4.18: DXF File Import

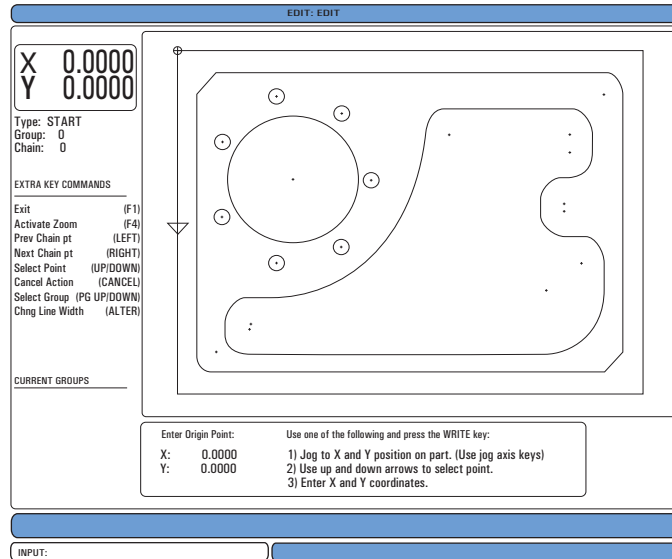

The DXF importer feature provides an on-screen help throughout the process. The step outline box shows which steps are completed by turning the text green at each completed step. The keys needed are defined beside the steps. Additional keys are identified in the left hand column for advanced use. Once a tool-path is completed it can be inserted into any program in memory. This feature will identify repetitive tasks and automatically execute them, for example, finding all the holes with the same diameter. Long contours are also automatically joined.



#### NOTE:

*DXF importer is only available with the IPS option.*

1. Start by setting up the cutting tools in IPS. Select a .dxf file
2. Press **[F2]**.
3. Select **[MEMORY]** and press **[ENTER]**. The control will recognize a DXF file and import it into the editor.

## 4.5.1 Part Origin

Use one of these three methods to set the part origin.

- Point Selection
- Jogging
- Enter Coordinates

1. The jog handle or arrow buttons are used to highlight a point.
2. Press **[ENTER]** to accept the highlighted point as the origin. This is used to set the work coordinate information of the raw part.

## 4.5.2 Part Geometry Chain and Group

This step finds the geometry of the shape(s). The auto chaining function will find most part geometry. If the geometry is complex and branches off a prompt will display so the operator can select one of the branches. The automatic chaining will continue once a branch is selected. Similar holes are grouped together for drilling and/or tapping operations.

### F4.19: DXF Import Chain/Group Menus

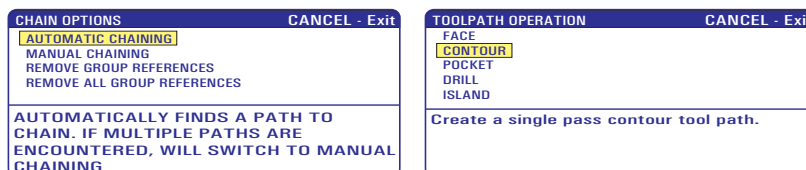

1. Use the jog handle or arrow buttons to choose the starting point of the tool path.
2. Press **[F2]** to open the dialog box.
3. Choose the option that best suits the desired application. The Automatic Chaining function is typically the best choice as it will automatically plot the tool path for a part feature.
4. Press **[ENTER]**. This will change the color of that part feature and add a group to the register under **Current group** on the left hand side of the window.

## 4.5.3 Toolpath Selection

This step applies a toolpath operation to a particular chained group.

### F4.20: DXF IPS Recorder Menu

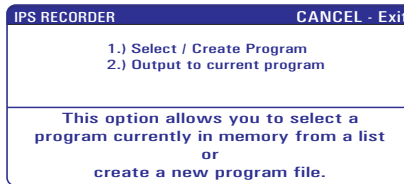

1. Select the group and press **[F3]** to choose a tool path.
2. Use the jog handle to bisect an edge of the part feature; this will be used as an entry point for the tool.  
  
Once a toolpath is selected, the IPS (Intuitive Programming System) template for that path will display.  
  
Most IPS templates are filled with reasonable defaults. They are derived from tools and materials that have been set up.
3. Press **[F4]** to save the toolpath once the template is completed; either add the IPS G code segment to an existing program or create a new program. Press **[EDIT]** to return to the DXF import feature to create the next tool path.

## 4.6 Basic Programming

A typical CNC program has (3) parts:

1. **Preparation:**  
This portion of the program selects the work and tool offsets, selects the cutting tool, turns on the coolant, and selects absolute or incremental positioning for axis motion.
2. **Cutting:**  
This portion of the program defines the tool path, spindle speed, and feed rate for the cutting operation.
3. **Completion:**  
This portion of the program moves the spindle out of the way, turns off the spindle, turns off the coolant, and moves the table to a position from where the part can be unloaded and inspected.

This is a basic program that makes a 0.100" (2.54 mm) deep cut with Tool 1 in a piece of material along a straight line path from X=0.0, Y=0.0 to X=4.0, Y=4.0. Note that the line numbers given here are for reference; they should not be included in the actual program.



**NOTE:**

*A program block can contain more than one G-code, as long as those G-codes are from different groups. You cannot place two G-codes from the same group in a program block. Also note that only one M-code per block is allowed.*

```
1. % (Preparation)
2. O00100 (Basic Program - Preparation) ;
3. M06 T01 (Preparation) ;
4. G00 G90 G54 X0. Y0. (Preparation) ;
5. S5200 M03 (Preparation) ;
6. G43 H01 Z0.1 M08 (Preparation) ;
7. G01 F20.0 Z-0.1 (Cutting) ;
8. X4.0 Y4.0 (Cutting) ;
9. G00 Z0.1 M09 (Completion) ;
10. G53 Y0 Z0 (Completion) ;
11. M30 (Completion) ;
12. % (Completion)
```

## 4.6.1 Preparation

These are the preparation code blocks in the sample program:

Preparation Code Block	Description
%	Denotes the beginning of a program written in a text editor.
O00100 (Basic Program)	O00100 is the name of the program. Program naming convention follows the Onnnnn format: The letter “O” followed by a 5-digit number.
M06 T01 ;	Selects the tool to be used. M06 is used to command the tool changer to load Tool 1 (T01) into the spindle.
G00 G90 G17 G40 G80 G54 X0. Y0. ;	This is referred to as a safe startup line. It is good machining practice to place this block of code after every tool change. G00 defines axis movement following it to be completed in Rapid Motion mode. G90 defines axis movements following it to be completed in incremental mode (refer to page 143 for more information). G54 defines the coordinate system to be centered on the Work Offset stored in G54 on the Offset display. G17 defines the cutting plane as the XY plane. G40 cancels Cutter Compensation. G80 cancels any canned cycles. X0. Y0. commands the table to move to the position X=0.0 and Y=0.0 in the current coordinate system.
S5200 M03 ;	M03 turns the spindle on. It takes the address code Snnnn, where nnnn is the desired spindle RPM. On machines with a gearbox, the control automatically selects high gear or low gear, based on the commanded spindle speed. You can use an M41 or M42 to override this. Refer to page 328 for more information on these M-codes.
G43 H01 Z0.1 M08 ;	G43 H01 turns on Tool Length Compensation +. The H01 specifies to use the length stored for Tool 1 in the Tool Offset display. Z0.1 commands the Z Axis to Z=0.1. M08 commands the coolant to turn on.

## 4.6.2 Cutting

These are the cutting code blocks in the sample program:

Cutting Code Block	Description
G01 F20.0 Z-0.1 ;	G01 F20.0 defines axis movements following it to be completed in a straight line. G01 requires the address code Fnnn.nnnn. The address code F20.0 specifies that the feed rate for the motion is 20.0" (508 mm) / min. Z-0.1 commands the Z Axis to Z=-0.1.
X4.0 Y4.0 ;	X4.0 Y4.0 commands the X Axis to move to X=4.0 and commands the Y Axis to move to Y=4.0.

## 4.6.3 Completion

These are the completion code blocks in the sample program:

Completion Code Block	Description
G00 Z0.1 M09 ;	G00 commands the axis motion to be completed in rapid motion mode. Z0.1 Commands the Z Axis to Z=0.1. M09 commands the coolant to turn off.
G53 Y0 Z0 ;	G53 defines axis movements following it to be with respect to the machine coordinate system. Y0 Z0 is a command to move to Y=0.0, Z=0.0.
M30 ;	M30 ends the program and moves the cursor on the control to the top of the program.
%	Denotes the end of a program written in a text editor.

## 4.6.4 Absolute vs. Incremental (G90, G91)

Absolute (G90) and incremental positioning (G91) define how the control interprets axis motion commands.

When you command axis motion after a G90 code, the axes move to that position relative to the origin of the coordinate system currently in use.

When you command axis motion after aG91, the axes move to that position relative to the current position.

Absolute programming is useful in most situations. Incremental programming is more efficient for repetitive, equally spaced cuts.

Figure F4.21 shows a part with 5 equally spaced 0.5" (12.7 mm) diameter holes. The hole depth is 1.00" (25.4 mm) and the spacing is 1.25" (31.75 mm) apart.

**F4.21:** Absolute / Incremental Sample Part

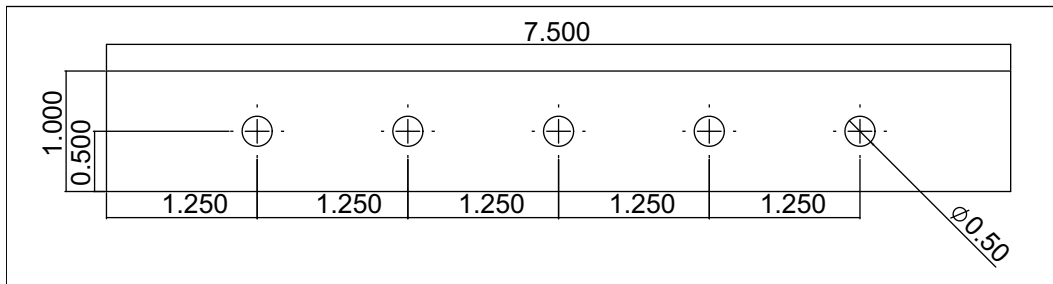

Below are two example programs for drilling the holes for the part in the drawing, with a comparison between absolute and incremental positioning. We start the holes with a center drill, and finish drilling the holes with a 1/4" (6.35 mm) drill bit. We use a 0.2" (5.08 mm) depth of cut for the center drill and 1.00" (25.4 mm) depth of cut for the 1/4" drill. G81, Drill Canned Cycle, is used to drill the holes.

Note that the line numbers given here are for reference; they should not be included in the actual program.

### Incremental Program

```
1. % (Preparation)
2. O00103 (Incremental Programming - Preparation) ;
3. M06 T01 (Preparation) ;
4. G00 G90 G54 G17 G40 G80 X0. Y0. (Preparation) ;
5. S1528 M03 (Preparation);
6. G43 H01 Z0.1 M08 (Preparation) ;
7. G99 G91 G81 F8.15 X1.25 Z-0.3 L5 (Cutting) ;
8. G00 G53 Z0. M09 (Completion) ;
9. M06 T02 (Preparation) ;
10. G00 G90 G54 G17 G40 G80 X0. Y0. S5350 (Preparation) ;
11. G43 H02 Z0.1 M08 (Preparation) ;
12. G99 G91 G81 F21.4 X1.25 Z-1.1 L5 (Cutting) ;
13. G80 (Completion) ;
14. G00 Z0.1 M09 (Completion) ;
15. G53 Y0. Z0. (Completion) ;
16. M30 (Completion) ;
```

17. % (Completion)

### Absolute Program

```

21. % (Preparation)
22. O00104 (Absolute Programming) (Preparation) ;
23. M06 T01 (Preparation) ;
24. G00 G90 G54 G17 G40 G80 X0. Y0. (Preparation) ;
25. S1528 M03 (Preparation) ;
26. G43 H01 Z0.1 M08 (Preparation) ;
27. G99 G81 F8.15 X0. Z-0.2 (Cutting) ;
28. X1.25 (Cutting) ;
29. X2.5 (Cutting) ;
30. X3.75 (Cutting) ;
31. X5. (Cutting) ;
32. G80 (Completion) ;
33. G00 G53 Z0. M09 (Preparation) ;
34. M06 T02 (Preparation) ;
35. G00 G90 G54 G17 G40 G80 X0. Y0. S5350 (Preparation) ;
36. G43 H02 Z0.1 M08 (Preparation) ;
37. G99 G81 F21.4 X0. Z-1.0 (Cutting) ;
38. X1.25 (Cutting) ;
39. X2.5 (Cutting) ;
40. X3.75 (Cutting) ;
41. X5. (Cutting) ;
42. G80 (Completion) ;
43. G00 Z0.1 M09 (Completion) ;
44. G53 Y0. Z0. (Completion) ;
45. M30 (Completion) ;
46. % (Completion)

```

The absolute programming method requires 9 more lines of code than the incremental programming method. Lines 1-6 and lines 21-26 are the same as lines 1-6 used in the basic programming example. Lines 14-17 and lines 43-46 are the same as lines 9-12 in the basic programming example. These lines are part of the preparation and completion sections of the code.

Look at line 7 in the incremental programming example, where the center drill operation begins. G81 uses the loop address code, Lnn. The loop address code repeats the canned cycle. Each time the canned cycle repeats, it moves the distance that the optional X and Y values specify. The incremental program moves 1.25" in the X direction with each loop. G80 cancels the drill canned cycle before the next cutting operation.

In absolute positioning, G81 does not use the loop address code. The depth of Z-1.0 is used in the absolute program, because the depth starts at the part surface (Z=0). The incremental program must command a drill depth of -1.1" to drill 1" deep, because it starts from 0.1" above the part.

X0 . specifies the location to perform the first drill canned cycle. The drill operation occurs at each of the X or Y coordinates given in the blocks of code between the G81 and G80 commands. Lines 28-31 and lines 38-41 are the coordinates where the drill operation is repeated.

Refer to page 231 for more information on canned cycles.

## 4.7 Tool and Work Offset Calls

### 4.7.1 G43 Tool Offset

The G43 Hnn Tool Length Compensation command should be used after every tool change. It adjusts the Z-Axis position to account for the length of the tool. The Hnn argument specifies which tool length to use. The nn value should match the nn value from the M06 Tnn tool change command. Setting 15 - H & T Code Agreement controls whether the nn value needs to match in the Tnn and Hnn arguments. If Setting 15 is **ON** and the Tnn and Hnn do not match, *Alarm 332 - H and T Not Matched* is generated. For more information see Reference Tool Offsets in the Operation section.

### 4.7.2 G54 Work Offsets

Work Offsets define where a work piece is located on the table. Work Offsets available are G54-G59, G110-G129, and G154 P1-P99. G110-G129 and G154 P1-P20 refer to the same Work Offsets. A useful feature is to set up multiple work pieces on the table and machining multiple parts in one machine cycle. This accomplished by assigning each work piece to a different Work Offset. For more information, reference the G-code section of this manual. Below is an example of machining multiple parts in one cycle. The program uses M97 Local Sub-Program Call to the cutting operation.

```
%  
O00105;  
M06 T01;  
G00 G90 G54 G17 G40 G80 X0. Y0. (Safe Startup Line);  
G43 H01 Z0.1 M08;  
M97 P1000;  
G00 G90 G110 G17 G40 G80 X0. Y0.;  
M97 P1000;  
G00 G90 G154 P22 G17 G40 G80 X0. Y0.;  
M97 P1000;  
G00 Z0.1 M09;  
G53 Y0. Z0.M30;  
N1000 (Sub Program);
```

```
G81 F41.6 X1.0 Y2.0 Z-1.25;  
X2.0 Y2.0;  
G80 Z0.1;  
G00 G53 Z0;  
M99;  
%
```

## 4.8 Miscellaneous Codes

Frequently used M-codes are listed below. Most programs have at least one M-code from each of the following families. Refer to the M-code section of this manual, starting on page 318, for a listing of all M-codes with descriptions.

### 4.8.1 Tool Change Command

M06 T<sub>nn</sub> is the M-code for a tool change. The T<sub>nn</sub> address specifies the tool to load into the spindle. Tool numbers are stored in the Tool Table.

### 4.8.2 Spindle Commands

There are three primary spindle M-code commands:

- M03 S<sub>nnnn</sub> commands the spindle to rotate clockwise.
- M04 S<sub>nnnn</sub> commands the spindle to rotate counter-clockwise.



#### NOTE:

*The S<sub>nnnn</sub> address commands the spindle to rotate at nnnn RPM, up to the maximum spindle speed.*

- M05 commands the spindle to stop rotating.

### 4.8.3 Program Stop Commands

There are two main M-codes and one subprogram M-code to denote the end of a program or subprogram:

- M30 - Program End and Rewind ends the program and resets to the beginning of the program.
- M02 - Program End ends the program and remains at the location of the M02 block of code in the program.

- M99 - Sub-Program Return or Loop exits the subprogram and resumes the program that called it.



**NOTE:**

*Failure to place an M99 at the end of a sub-program can result in Alarm 312 - Program End.*

### 4.8.4 Coolant Commands

Use M08 to command standard coolant on. Use M09 to command standard coolant off. Refer to page 321 for more information on these M-codes.

If your machine has Through-Spindle Coolant (TSC), use M88 to command it on, and M89 to command it off.

## 4.9 Cutting G-codes

The main cutting G-codes are categorized into interpolation motion and canned cycles. Interpolation motion cutting codes are broken down into:

- G01 - Linear Interpolation Motion
- G02 - Clockwise Circular Interpolation Motion
- G03 - Counter-Clockwise Circular Interpolation Motion
- G12 - Clockwise Circular Pocket Milling
- G13 - Counter-Clockwise Circular Pocket Milling

### 4.9.1 Linear Interpolation Motion

G01 Linear Interpolation Motion is used to cut straight lines. It requires a feedrate, specified with the Fnnn.nnnn address code. Xnn.nnnn, Ynn.nnnn, Znn.nnnn, and Annn.nnn are optional address codes to specify cut. Subsequent axis motion commands will use the feed rate specified by G01 until another axis motion, G00, G02, G03, G12, or G13 is commanded. Corners can be chamfered using the optional argument Cnn.nnnn to define the chamfer. Corners can be rounded using the optional address codeRnn.nnnn to define the radius of the arc. Refer to page 237 for more information on G01.



## 4.9.2 Circular Interpolation Motion

G02 and G03 are the G-codes for circular cutting motions. Circular Interpolation Motion has several optional address codes to define the arc or circle. The arc or circle begins cutting from the current cutter position [1] to the geometry specified within the G02/G03 command.

Arcs can be defined using two different methods. The preferred method is to define the center of the arc or circle with I, J and/or K and to define the end point [3] of the arc with an X, Y and/or Z. The I J K values define the relative X Y Z distances from the starting point [2] to the center of the circle. The X Y Z values define the absolute X Y Z distances from the starting point to the end point of the arc within the current coordinate system. This is also the only method to cut a circle. Defining only the I J K values and not defining the end point X Y Z values will cut a circle.

The other method to cut an arc is to define the X Y Z values for the end point and to define the radius of the circle with an R value.

Below are examples of using the two different methods to cut a 2" (mm) radius 180 degree counter-clockwise arc. The tool starts at X0 Y0 [1], moves to the starting point of the arc [2], and cuts the arc to the end point [3]:

### F4.22: Arc Cutting Example

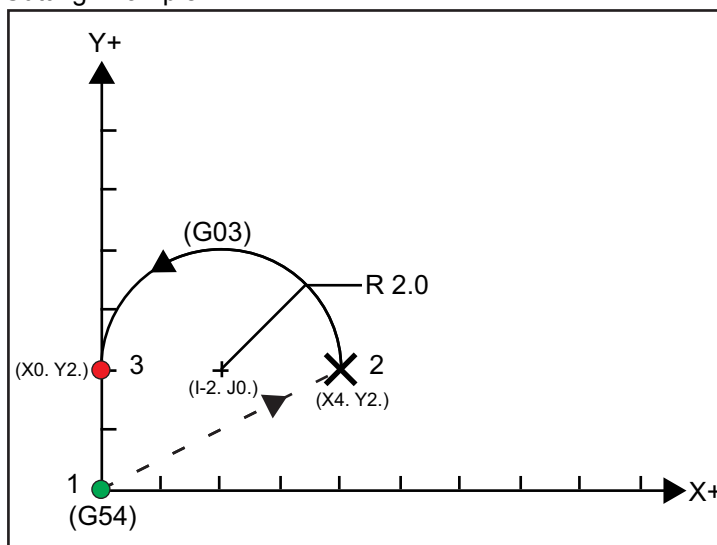

#### Method 1:

```
T01 M06 ;
...
G00 X4. Y2. ;
G01 F20.0 Z-0.1 ;
G03 F20.0 I-2.0 J0. X0. Y2. ;
```

```
...  
M30 ;
```

### Method 2:

```
T01 M06 ;  
...  
G00 X4. Y2. ;  
G01 F20.0 Z-0.1 ;  
G03 F20.0 X0. Y2. R2. ;  
...  
M30 ;
```

Below is an example of how to cut a 2" (mm) radius circle:

```
T01 M06 ;  
...  
G00 X4. Y2. ;  
G01 F20.0 Z-0.1 ;  
G02 F20.0 I2.0 J0. ;  
...  
M30 ;
```

## 4.10 Cutter Compensation

Cutter compensation is a method of shifting the tool path so that the actual centerline of the tool moves to either the left or right of the programmed path. Normally, cutter compensation is programmed to shift the tool in order to control feature size. The offset display is used to enter the amount that the tool is to be shifted. The offset can be entered as either a diameter or radius value, depending on Setting 40, for both the geometry and wear values. If diameter is specified, the shift amount is half of the value entered. The effective offset values are the sum of the geometry and wear values. Cutter compensation is only available in the X Axis and the Y Axis for 2D machining (G17). For 3D machining, cutter compensation is available in the X Axis, Y Axis, and Z Axis (G141).

## 4.10.1 General Description of Cutter Compensation

G41 will select cutter compensation left; that is, the tool is moved to the left of the programmed path to compensate for the amount entered in the offsets page (Refer to Setting 40). G42 will select cutter compensation right, which will move the tool to the right of the programmed path. A D<sub>nnn</sub> must also be programmed with G41 or G42 to select the correct offset number from the radius / diameter offset column. If the offset contains a negative value, cutter compensation will operate as though the opposite G code was specified. For example, a negative value entered for a G41 will behave as if a positive value was entered for G42. Also, if cutter compensation is selected (G41 or G42), you may only use the X-Y plane for circular motions (G17). Cutter Compensation is limited to compensation in only the X-Y plane.

The code G40 will cancel cutter compensation and is the default condition when a machine is powered on. When canceled, the programmed path is the same as the center of the cutter path. You may not end a program (M30, M00, M01, or M02) with cutter compensation active.

The control operates on one motion block at a time. However, it will look ahead to check the next two blocks containing X or Y motions. Interference checks are performed on these three blocks of information. Setting 58 controls how this part of cutter compensation works. It can be set to Fanuc or Yasnac.

Selecting Yasnac for Setting 58, the control must be able to position the side of the tool along all of the edges of the programmed contour without over cutting the next two motions. A circular motion joins all of the outside angles.

Selecting Fanuc for Setting 58, the control does not require that the tool cutting edge be placed along all edges of the programmed contour, preventing over-cutting. However an alarm will be generated if the cutter's path is programmed such that over-cutting cannot be avoided. Outside angles less than or equal to 270 degrees are joined by a sharp corner and outside angles of more than 270 degrees are joined by an extra linear motion.

These diagrams show how cutter compensation works for the two possible values of Setting 58. Note that a small cut of less than the tool radius and at a right angle to the previous motion will only work with the Fanuc setting.

**F4.23:** Cutter Compensation, YASNAC Style, G41 with a Positive Tool Diameter or G42 with a Negative Tool Diameter: [1] Tool Path Actual Center, [2] Programmed Tool Path, [3] Start Point, [4] Cutter Compensation. G41 / G42 and G40 are commanded in the indicated program blocks.

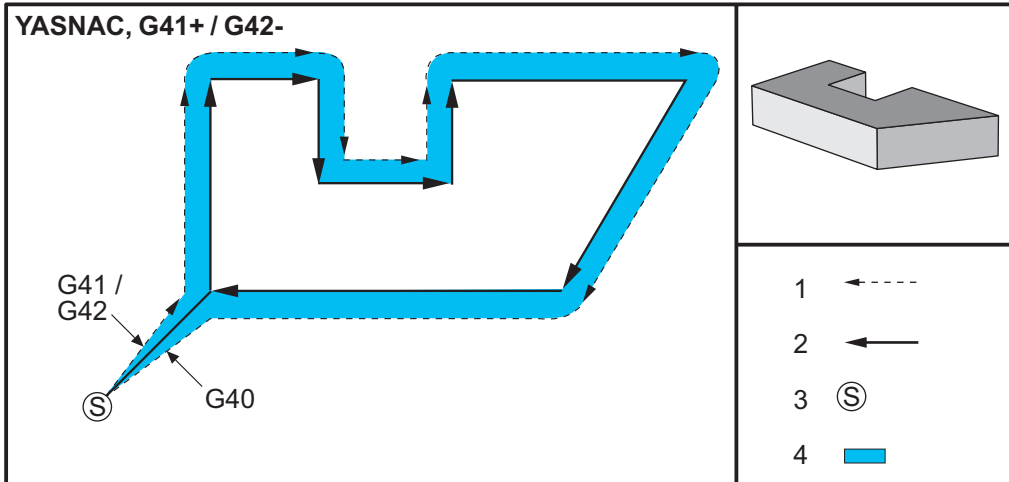

**F4.24:** Cutter Compensation, YASNAC Style, G42 with a Positive Tool Diameter or G41 with a Negative Tool Diameter: [1] Tool Path Actual Center, [2] Programmed Tool Path, [3] Start Point, [4] Cutter Compensation. G41 / G42 and G40 are commanded in the indicated program blocks.

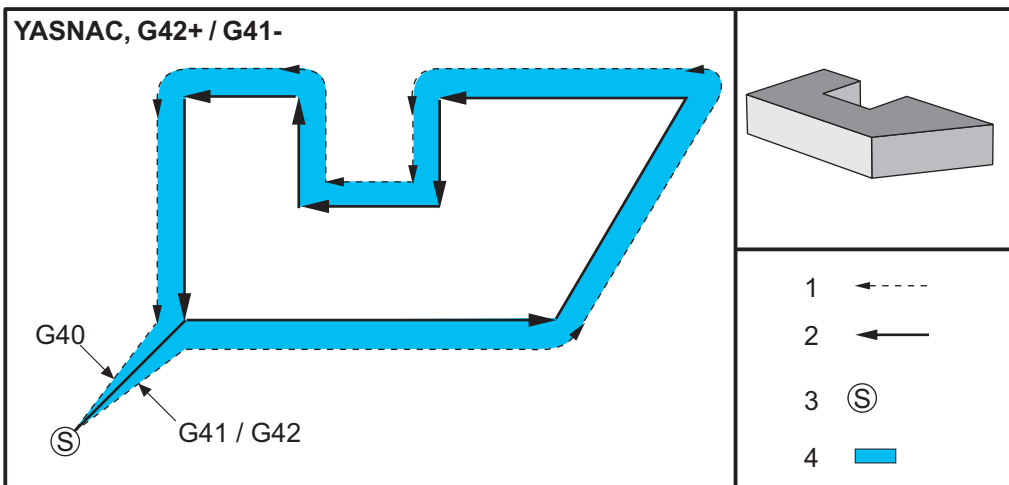

**F4.25:** Cutter Compensation, FANUC Style, G41 with a Positive Tool Diameter or G42 with a Negative Tool Diameter: [1] Tool Path Actual Center, [2] Programmed Tool Path, [3] Start Point, [4] Cutter Compensation. G41 / G42 and G40 are commanded in the indicated program blocks.

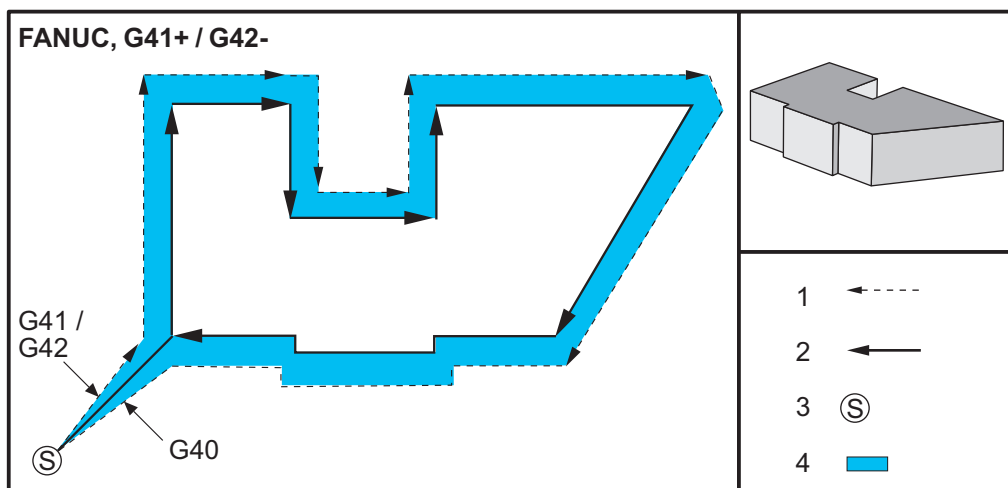

**F4.26:** Cutter Compensation, FANUC Style, G42 with a Positive Tool Diameter or G41 with a Negative Tool Diameter: [1] Tool Path Actual Center, [2] Programmed Tool Path, [3] Start Point, [4] Cutter Compensation. G41 / G42 and G40 are commanded in the indicated program blocks.

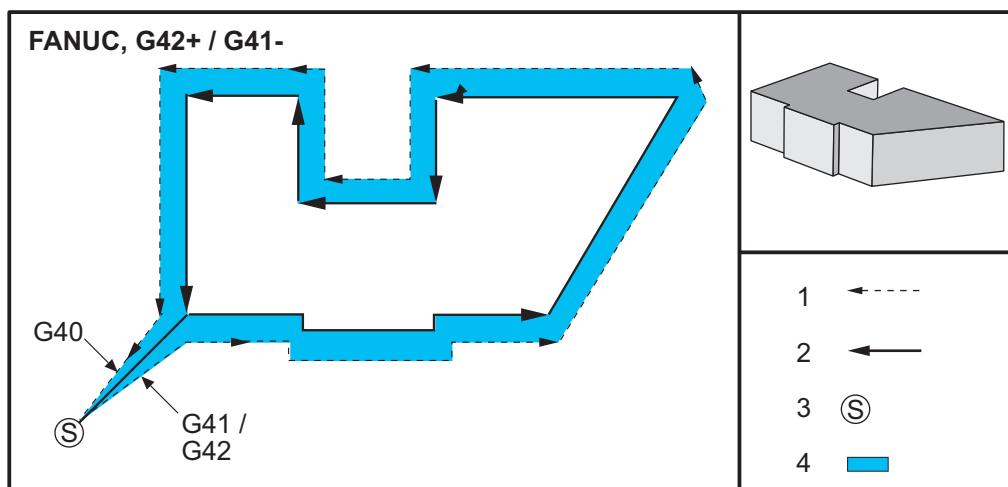

4

## 4.10.2 Entry and Exit from Cutter Compensation

When entering and exiting cutter compensation, or when changing from left side to right side compensation, there are special considerations to be aware of. Cutting should not be performed during any of these moves. To activate cutter compensation, a nonzero `D` code must be specified with either `G41` or `G42` and `G40` must be specified in the line that cancels cutter compensation. In the block that turns on cutter compensation, the starting position of the move is the same as the programmed position, but the ending position will be offset, to either the left or right of the programmed path, by the amount entered in the, radius/diameter, offset column.

In the block that turns off cutter compensation, the starting point is offset and the ending point is not offset. Similarly, when changing from left to right or right to left side compensation, the starting point of the move needed to change cutter compensation direction will be offset to one side of the programmed path and end at a point that is offset to the opposite side of the programmed path. The result of all this is that the tool moves through a path that may not be the same as the intended path or direction.

If cutter compensation is turned on or off in a block without any X-Y move, there is no change made to cutter compensation until the next X or Y move is encountered. To exit from cutter compensation, you must specify `G40`.

You should always turn off cutter compensation in a move that clears the tool away from the part being cut. If a program is terminated with cutter compensation still active, an alarm is generated. In addition, you cannot turn cutter compensation on or off during a circular move (`G02` or `G03`); otherwise an alarm will be generated.

An offset selection of `D0` will use zero as the offset value and have the same effect as turning off cutter compensation. If a new `D` value is selected while cutter compensation is already active, the new value will take effect at the end of the proceeding move. You cannot change the `D` value or change sides during a circular motion block.

When turning on cutter compensation in a move that is followed by a second move at an angle of less than 90 degrees, there are two ways of computing the first motion: cutter compensation type A and type B (Setting 43). Type A is the default in Setting 43 and is what is normally needed; the tool moves directly to the offset start point for the second cut. Type B is used when clearance around a fixture or clamp is needed, or in rare cases when part geometry demands it. The diagrams on the following pages illustrate the differences between type A and type B for both Fanuc and Yasnac settings (Setting 58).

## Improper Cutter Compensation Application

**F4.27:** Improper Cutter Compensation: [1] Move is less than cutting comp radius, [2] Workpiece, [3] Tool.

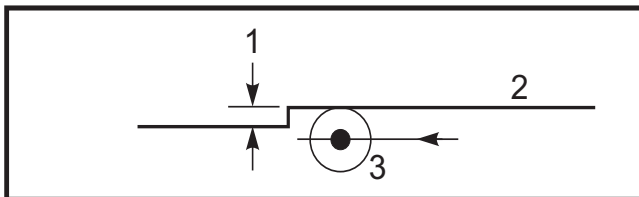

**NOTE:**

*A small cut of less than tool radius and at a right angle to the previous motion will only work with the Fanuc setting. A cutter compensation alarm will be generated if the machine is set to the Yasnac setting.*

### 4.10.3 Feed Adjustments in Cutter Compensation

When using cutter compensation in circular moves, there is the possibility of speed adjustments to what has been programmed. If the intended finish cut is on the inside of a circular motion, the tool should be slowed down to ensure that the surface feed does not exceed what was intended by the programmer. There are problems, however, when the speed is slowed by too much. For this reason, Setting 44 is used to limit the amount by which the feed is adjusted in this case. It can be set between 1% and 100%. If set to 100%, there will be no speed changes. If set to 1%, the speed can be slowed to 1% of the programmed feed.

When the cut is on the outside of a circular motion, there is no speed-up adjustment made to the rate feed.

## Cutter Compensation Entry (Yasnac)

**F4.28:** Cutter Compensation Entry (Yasnac) Type A and B: [1] Programmed Path, [2] Tool Center Path, [r] Tool Radius

TYPE A

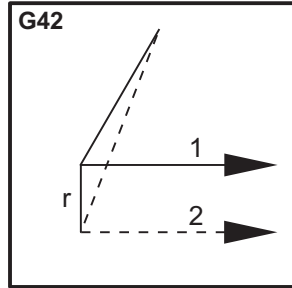

TYPE B

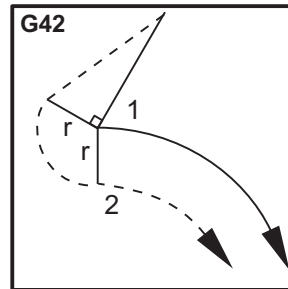
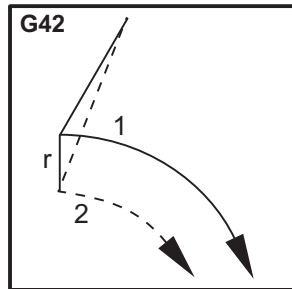
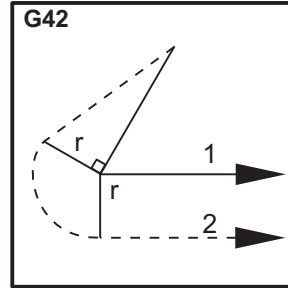



## Cutter Compensation Entry (Fanuc style)

**F4.29:** Cutter Compensation Entry (Fanuc style) Type A and B: [1] Programmed Path, [2] Tool Center Path, [r] Tool Radius

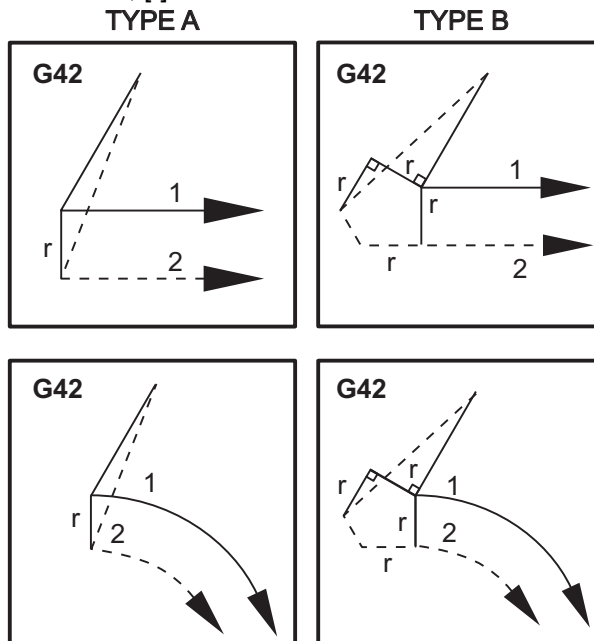

### 4.10.4 Circular Interpolation and Cutter Compensation

In this section, the usage of G02 (Circular Interpolation Clockwise), G03 (Circular Interpolation Counterclockwise) and Cutter Compensation (G41: Cutter Compensation Left, G42: Cutter Compensation Right) is described.

Using G02 and G03, we can program the machine to cut circular moves and radii. Generally, when programming a profile or a contour, the easiest way to describe a radius between two points is with an R and a value. For complete circular moves (360 degrees), an I or a J with a value must be specified. The circle section illustration will describe the different sections of a circle.

By using cutter compensation in this section, the programmer will be able to shift the cutter by an exact amount and be able to machine a profile or a contour to the exact print dimensions. By using cutter compensation, programming time and the likelihood of a programming calculation error is reduced due to the fact that real dimensions can be programmed, and part size and geometry can be easily controlled.

The following are a few rules about cutter compensation that have to be closely followed in order to perform successful machining operations. Always refer to these rules when programming.

1. Cutter compensation must be turned ON during a G01 X, Y move that is equal to or greater than the cutter radius, or the amount being compensated.
2. When an operation using cutter compensation is done, the cutter compensation will need to be turned OFF, using the same rules as the turn ON process, i.e., what is put in must be taken out.
3. In most machines, during cutter compensation, a linear X,Y move that is smaller than the cutter radius may not work. (Setting 58 - set to Fanuc - for positive results.)
4. Cutter compensation cannot be turned ON or OFF in a G02 or G03 arc movement.
5. With cutter compensation active, machining an inside arc with a radius less than what is defined by the active D value will cause the machine to alarm.

### F4.30: Circle Sections

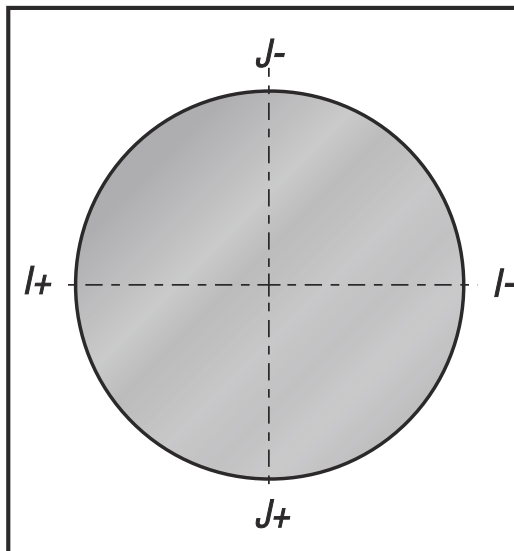

The following illustration shows how the tool path is calculated for the cutter compensation. The detail section shows the tool in the starting position and then in the offset position as the cutter reaches the workpiece.

**F4.31:** Circular Interpolation G02 and G03: [1] 0.250" diameter endmill, [2] Programmed path, [3] Center of Tool, [4] Start Position, [5] Offset Tool Path.

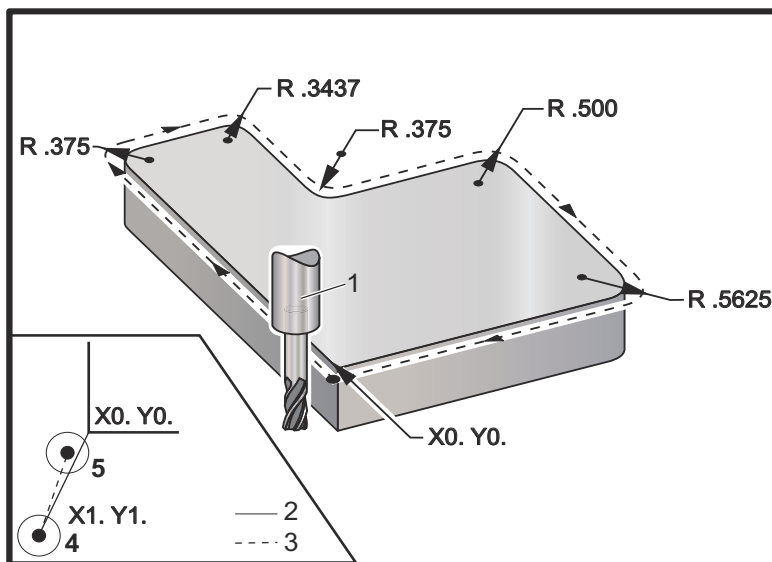

**Programming exercise showing tool path.**

This program uses cutter compensation. The toolpath is programmed to the centerline of the cutter. This is also the way the control calculates for cutter compensation.

```
O6100 ;
T1 M06 ;
G00 G90 G54 X-1. Y-1. S5000 M03 ;
G43 H01 Z.1 M08 ;
G01 Z-1.0 F50. ;
G41 G01 X0 Y0 D01 F50. ;
Y4.125 ;
G02 X.250 Y4.375 R.375 ;
G01 X1.6562 ;
G02 X2.0 Y4.0313 R.3437 ;
G01 Y3.125 ;
G03 X2.375 Y2.750 R.375 ;
G01 X3.5 ;
G02 X4.0 Y2.25 R.5 ;
G01 Y.4375 ;
G02 X3.4375 Y-.125 R.5625 ;
G01 X-.125 ;
G40 X-1. Y-1. ;
G00 Z1.0 M09 ;
G28 G91 Y0 Z0 ;
M30 ;
```

## 4.11 Canned Cycles

Canned cycles are G-codes used to perform repetitive operations such as drilling, tapping, and boring. When a canned cycle is active, canned operations are performed with every X or Y movement. Canned cycles are canceled with G80. It is good practice to end each canned cycle with a G80 to avoid part, fixture, or machine damage. Additionally, make sure to include a G80 within the safe startup line with every tool change.

### 4.11.1 Drilling Canned Cycles

All four drill canned cycles can be looped in G91, Incremental Programming mode.

- The G81 Drill Canned Cycle is the basic drilling cycle. It is used for drilling shallow holes or for drilling with Through Spindle Coolant (TSC).
- The G82 Spot Drill Canned Cycle is the same as the G81 Drill Canned Cycle except that it can dwell at the bottom of the hole. The optional argument Pn.nnn specifies the duration of the dwell.
- The G83 Normal Peck Drilling Canned Cycle is typically used for drilling deep holes. Peck depth can be variable or constant.
- The G73 High-Speed Peck Drilling Canned Cycle is the same as the G83 Normal Peck Drilling Canned Cycle except that tool peck retraction is specified with Setting 22 - Can Cycle Delta Z. Peck drilling cycles are advised for hole depths greater than 3 times the diameter of the drill bit. The initial peck depth, defined by I, should generally be a depth of 1 tool diameter.

### 4.11.2 Tapping Canned Cycles

There are two tapping canned cycles. All tapping canned cycles can be looped in G91, Incremental Programming mode.

- The G84 Tapping Canned Cycle is the normal tapping cycle. It is used for tapping right-hand threads.
- G74 Reverse Tap Canned Cycle is the reverse thread tapping cycle. It is used for tapping left-hand threads.

### 4.11.3 Boring and Reaming Cycles

There are seven boring canned cycles. All boring canned cycles can be looped in G91, Incremental Programming mode.

- The G85 Boring Canned Cycle is the basic boring cycle. It will bore down to the desired height and return to the specified height.

- The G86 Bore and Stop Canned Cycle is the same as the G85 Boring Canned Cycle except that the spindle will stop at the bottom of the hole before returning to the specified height.
- The G87 Bore In and Manual Retract Canned Cycle is also the same except that the spindle will stop at the bottom of the hole, the tool is manually jogged out of the hole, and the program will resume again when Cycle Start is pressed.
- The G88 Bore In, Dwell, Manual Retract Canned Cycle is the same as G87 except that there is a dwell before the operator can manually jog the tool out of the hole.
- The G89 Bore In, Dwell, Bore Out Canned Cycle is the same as G85 except that there is a dwell at the bottom of the hole, and the hole continues to be bored at the specified feed rate as the tool returns to the specified position. This differs from other boring canned cycles where the tool either moves in Rapid Motion or hand jog to return to the return position.
- The G76 Fine Boring Canned Cycle bores the hole to the specified depth and after boring the hole, moves to clear the tool from hole before retracting.
- The G77 Back Bore Canned Cycle works similar to G76 except that before beginning to bore the hole, it moves the tool to clear the hole, moves down into the hole, and bores to the specified depth.

#### 4.11.4 R Planes

R Planes, or return planes, are G-code commands that specify the Z Axis return height during canned cycles. The R Plane G-codes remain active for the duration of the canned cycle it is used with. G98 Canned Cycle Initial Point Return moves the Z axis to the height of the Z axis prior to the canned cycle. G99 Canned Cycle R Plane Return moves the Z axis to the height specified by the Rnn.nnnn argument specified with the canned cycle. For additional information, refer to the G and M-code section.

### 4.12 Special G-codes

Special G-codes are used for complex milling. These include:

- Engraving (G47)
- Pocket Milling (G12, G13, and G150)
- Rotation and Scaling (G68, G69, G50, G51)
- Mirror Image (G101 and G100)

#### 4.12.1 Engraving

The G47 Text Engraving G-code allows you to engrave text or sequential serial numbers with a single block of code. There is support for ASCII characters as well.

Refer to page 257 for more information on engraving.

## 4.12.2 Pocket Milling

There are two types of pocket milling G-codes on the Haas control:

- Circular Pocket Milling is performed with the G12 Clockwise Circular Pocket Milling Command and the G13 Counter-Clockwise Circular Pocket Milling Command G-codes.
- The G150 General Purpose Pocket Milling uses a subprogram to machine user-defined pocket geometries.

Make sure that the subprogram geometry is a fully closed shape. Make sure that the X-Y starting point in the G150 command is within the boundary of the fully closed shape. Failure to do so may cause Alarm 370 - Pocket Definition Error.

Refer to page 246 for more information on the pocket milling G-codes.

## 4.12.3 Rotation and Scaling

G68 Rotation is used to rotate the coordinate system in the desired plane. It requires that a plane is defined before the G68 command, and it requires the coordinates for the center of rotation and the rotation angle. This feature can be used in conjunction with G91 Incremental Programming mode to machine symmetrical patterns. Rotation is canceled with a G69 Cancel Rotation command.

G51 Scaling is used to scale the positioning values in blocks following the G51 command. Scaling is canceled with a G50 Cancel Scaling command. Scaling can be used with G68 Rotation. However, use G51 Scaling before using G68 Rotation and cancel G51 after cancelling G68.

Refer to page 266 for more information on the rotation and scaling G-codes.

## 4.12.4 Mirror Image

G101 Enable Mirror Image will mirror axis motion about the specified axis. Settings 45-48, 80 and 250 enable mirror imaging about the X, Y, Z, A, B and C axes. The mirror pivot point along an axis is defined by the Xnn.nn argument. This can be specified for a Y Axis that is enabled on the machine and in the settings by using the axis to mirror as the argument. G100 cancels G101.

Refer to page 288 for more information on the mirror image G-codes.

## 4.13 Subroutines

Subroutines (subprograms) are usually a series of commands that are repeated several times in a program. Instead of repeating the commands many times in the main program, subroutines are written in a separate program. The main program then has a single command that calls the subroutine program. If a subroutine is called using an M97 and a P address, the P code is the same as the line number ( Nnnnnn) of the subroutine to be called, that is located after an M30. A subprogram is called using an M98 and a P address. The P address with an M98 is for the program number ( Onnnnn).

Canned Cycles are the most common use of subroutines. The X and Y locations of the holes are placed in a separate program and then called. Instead of writing the X, Y locations once for each tool, the X, Y locations are written once for any number of tools.

The subroutines can include a loop count with the address code L. If there is an L, the subroutine call is repeated that number of times before the main program continues with the next block.

### 4.13.1 External Subroutine (M98)

An external subroutine is a separate program that is referenced several times by the main program. External subroutines are commanded (called) using an M98 and a Pnnnnn which refers it to the program number of the subprogram.

#### External Subroutine Example

```

O00104 (sub program with an M98) ;
T1 M06 ;
G90 G54 G00 ;
S1406 M03Y-2.25 ;
G43 H01 Z1. M08 ;
G81 G99 Z-0.26 R0.1 F7. ;
M98 P105 (Call Sub-Program 000105) ;
T2 M06 ;
G90 G54 G00 X1.5 Y-0.5 ;
S2082 M03 ;
G43 H02 Z1. M08 ;
G83 G99 Z-.75 Q0.2 R0.1 F12.5 ;
M98 P105 (Call Sub-Program 000105) ;
T3 M06 ;
G90 G54 G00 X1.5 Y-0.5 ;
S750 ;
G43 H03 Z1. M08 ;
G84 G99 Z-.6 R0.1 F37.5 ;
M98 P105 (Call Sub-Program 000105) ;
G53 G49 Y0. ;
M30 (End Program) ;

```

**F4.32:** Sub Program Pattern Drawing

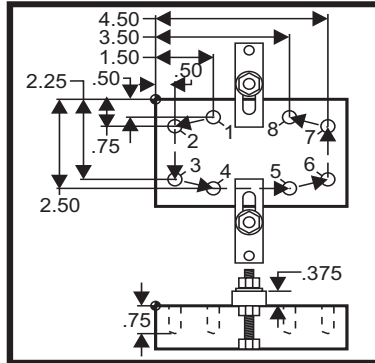

**Sub Program**

```
O00105 ;  
X.5 Y-.75 ;  
Y-2.5 ;  
G98 X1.5 Y-2.5 ;  
G99 X3.5 ;  
X4.5 Y-2.25 ;  
Y-.75 ;  
X3.5 Y-.5 ;  
G80 G00 Z1.0 M09 ;  
G53 G49 Z0. M05 ;  
M99 ;
```



## 4.13.2 Local Subroutine (M97)

A local subroutine is a block of code in the main program that is referenced several times by the main program. Local subroutines are commanded (called) using an M97 and Pnnnnn, which refers to the N line number of the local subroutine.

The local subroutine format is to end the main program with an M30 then enter the local subroutines after the M30. Each subroutine must have an N line number at the start and a M99 at the end that will send the program back to the next line in the main program.

### Local Subroutine Example

```
O00104 (local sub program with an M97) ;
T1 M06 ;
G90 G54 G00 X1.5 Y-0.5 ;
S1406 M03 ;
G43 H01 Z1. M08 ;
G81 G99 Z-0.26 R0.1 F7. ;
M97 P1000 (Call local subroutine at line N1000) ;
T2 M06 ;
G90 G54 G00 X1.5 Y-0.5 ;
S2082 M03 ;
G43 H02 Z1. M08 ;
G83 G99 Z-.75 Q0.2 R0.1 F12.5 ;
M97 P1000 (Call local subroutine at line N1000) ;
T3 M06 ;
G90 G54 G00 X1.5 Y-0.5 ;
S750 ;
G43 H03 Z1. M08 ;
G84 G99 Z-.6 R0.1 F37.5 ;
M97 P1000 (Call local subroutine at line N1000) ;
G53 G49 Y0. ;
M30 (End Program) ;
N1000 (Begin local subroutine) ;
X.5 Y-.75 ;
Y-2.25 ;
G98 X1.5 Y-2.5 ;
G99 X3.5 ;
X4.5 Y-2.25 ;
Y-.75 ;
X3.5 Y-.5 ;
G80 G00 Z1.0 M09 ;
G53 G49 Z0. M05 ;
M99 ;
```

### 4.13.3 External Subroutine Canned Cycle Example (M98)

```
O1234 (Canned Cycle Example Program) ;
T1 M06 ;
G90 G54 G00 X.565 Y-1.875 S1275 M03 ;
G43 H01 Z.1 M08 ;
G82 Z-.175 P.03 R.1 F10. ;
M98 P1000 ;
G80 G00 Z1.0 M09 ;
T2 M06
G00 G90 G54 X.565 Y-1.875 S2500 M03 ;
G43 H02 Z.1 M08 ;
G83 Z-.720 Q.175 R.1 F15. ;
M98 P1000 ;
G00 G80 Z1.0 M09 ;
T3 M06 ;
G00 G90 G54 X.565 Y-1.875 S900 M03 ;
G43 H03 Z.2 M08 ;
G84 Z-.600 R.2 F56.25 ;
M98 P1000 ;
G80 G00 Z1.0 M09 ;
G28 G91 Y0 Z0 ;
M30 ;
```

#### Sub Program

```
O1000 (X,Y Locations) ;
X 1.115 Y-2.750 ;
X 3.365 Y-2.875 ;
X 4.188 Y-3.313 ;
X 5.0 Y-4.0 ;
M99 ;
```

### 4.13.4 External Subroutines With Multiple Fixtures (M98)

Subroutines can be useful when cutting the same part in different X and Y locations within the machine. For example, there are six vises mounted on the table. Each of these vises uses a new X, Y zero. They are referenced in the program using the G54 through G59 work offsets. Use an edge finder or an indicator to establish the zero point on each part. Use the part zero set key in the work offset page to record each X, Y location. Once the X, Y zero position for each workpiece is in the offset page, the programming can begin.

The figure shows what this setup would look like on the machine table. For an example, each of these six parts will need to be drilled at the center, X and Y zero.

#### Main Program

```

O2000 ;
T1 M06 ;
G00 G90 G54 X0 Y0 S1500 M03 ;
G43 H01 Z.1 M08 ;
M98 P3000 ;
G55 ;
M98 P3000 ;
G56 ;
M98 P3000 ;
G57 ;
M98 P3000 ;
G58 ;
M98 P3000 ;
G59 ;
M98 P3000 ;
G00 Z1.0 M09 ;
G28 G91 Y0 Z0 ;
M30 ;

```

#### F4.33: Subroutine Multiple Fixture Drawing

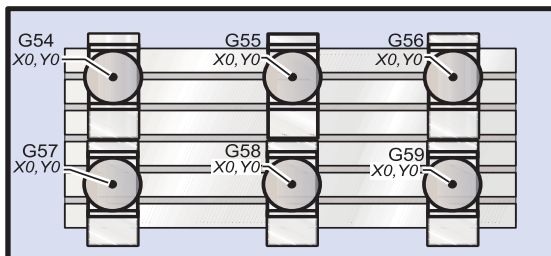

#### Subroutine

```

O3000 ;
X0 Y0 ;
G83 Z-1.0 Q.2 R.1 F15. ;
G00 G80 Z.2 ;
M99 ;

```

## 4.14 More Information Online

For updated and supplemental information, including tips, tricks, maintenance procedures, and more, go to [www.HaasCNC.com](http://www.HaasCNC.com) and select the **Resource Center**.



# Chapter 5: Options Programming

## 5.1 Options Programming

In addition to the standard functions included with your machine, you may also have optional equipment with special programming considerations. This section tells you how to program these options.

You can contact your HFO to purchase most of these options, if your machine did not come equipped with them.

## 5.2 4th and 5th Axis Programming

**F5.1:** Axis Motion on VR-11 and TRT-210: [A] A Axis, [B] B Axis

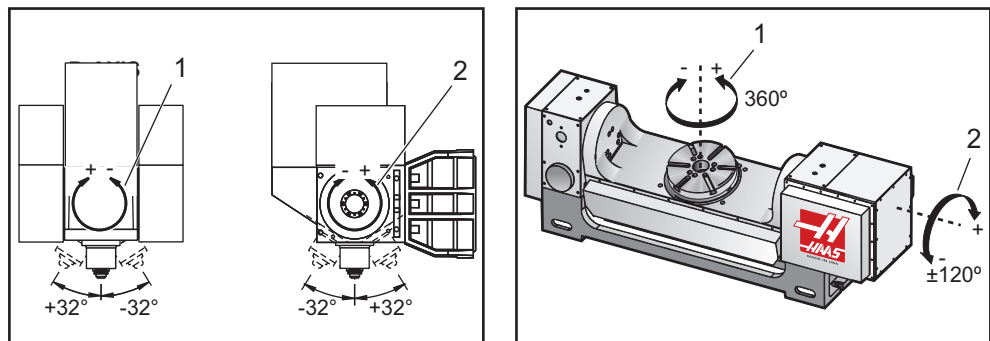

### 5.2.1 Creating Five-Axis Programs

Most five-axis programs are rather complex and should be written using a CAD/CAM package. It is necessary to determine the pivot length and gauge length of the machine, and input them into these programs.

Each machine has a specific pivot length. This is the distance from the spindle head's center of rotation to the bottom surface of the master tool holder. The pivot length can be found in Setting 116, and is also engraved into the master tool holder that is shipped with a 5-axes machine.

**F5.2:** Pivot and Gauge Length Diagram: [1] Axis of Rotation, [2] Pivot Length, [3] Gauge Length, [4] Total

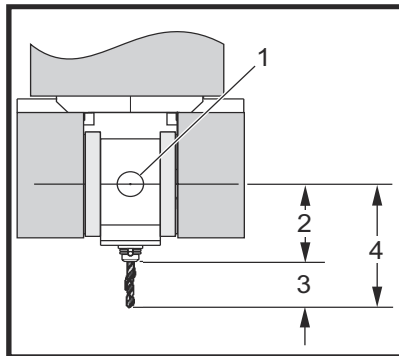

When setting up a program, it is necessary to determine gauge length for each tool. Gauge length is the distance from the bottom flange of the master tool holder to the tip of the tool. This distance can be calculated:

1. Set magnetic base indicator on the table.
2. Indicate the bottom surface of the master tool holder.
3. Set this point as  $Z0$  in the control.
4. Insert each tool and calculate distance from the tool tip to  $Z0$ ; this is the gauge length.
5. The total length is the distance from the spindle head center of rotation to the tip of the tool. It can be calculated by adding the gauge length and pivot length. This number is entered into the CAD/CAM program, which will use the value for its calculations.

## Offsets

The work-offset display is found on the offset display. The G54 through G59 or G110 through G129 offsets can be set by using the **[PART ZERO SET]** button. This will work with only the work zero offsets display selected.

1. Press **[OFFSET]** until the Work Zero Offset (from all modes except MEM) displays.
2. Position the axes to the work zero point of the workpiece.
3. Using the cursor, select the proper axis and work number.
4. Press **[PART ZERO SET]** and the current machine position will be automatically stored in that address.

**NOTE:**

*Entering a nonzero Z work offset will interfere with the operation of an automatically entered tool length offset.*

5. Work coordinate numbers are usually entered as positive numbers. Work coordinates are entered into the table as a number only. To enter an X value of X2.00 into G54, cursor to the X column and enter 2.0.

## Five-Axis Programming Notes

Use a tight synchronization cut across resolution of geometry in the CAD/CAM system will allow smooth flowing contours and a more accurate part.

Positioning the machine to an approach vector should only be done at a safe distance above or to the side of the workpiece. When in the rapid mode, the axes will arrive at the programmed position at different times; the axis with shortest distance from target will arrive first, and longest distance last. A high feed rate will force the axes to arrive at the commanded position at the same time avoiding the possibility of a crash.

## G-codes

5th-axis programming is not affected by the selection of inch (G20) or metric (G21), because the A and B Axes are always programmed in degrees.

G93 inverse time must be in effect for simultaneous 4- or 5-axis motion. Refer to “G93” on page **285** for more information.

Limit the post processor (CAD/CAM software) to a maximum G93 F value of 45000. This results in smoother motion, which may be necessary when fanning around tilted walls.

## M-codes

**IMPORTANT:** *It is highly recommended that the A/B brakes be engaged when doing any non 5-axis motion. Cutting with the brakes off can cause excessive wear in the gear sets.*

M10/M11 engages/disengages the A-Axis brake

M12/M13 engages/disengages the B-Axis brake

When in a 4 or 5 axis cut, the machine will pause between blocks. This pause is due to the A and/or B Axis brakes releasing. To avoid this dwell and allow for smoother program execution, program an M11 and/or M13 just before the G93. The M-codes will disengage the brakes, resulting in a smoother and uninterrupted flow of motion. Remember that if the brakes are never re-engaged, they remain off indefinitely.

## Settings

A number of settings are used to program the 4th and 5th axis. See Settings 30, 34 and 48 for the 4th axis and 78, 79 and 80 for the 5th axis.

Setting 85 should be set to .0500 for 5-axis cutting. Settings lower than .0500 will move the machine closer to an exact stop and cause uneven motion.

You can also use G187 Pxx Exx in the program to slow the axes down.



### CAUTION:

*When cutting in 5-axis mode poor positioning and over-travel can occur if the tool length offset (H-code) is not canceled. To avoid this problem use G90, G40, H00, and G49 in the first blocks after a tool change. This problem can occur when mixing 3-axis and 5-axis programming, restarting a program or when starting a new job and the tool length offset is still in effect.*

## Feed Rates

You can command a feed in a program using G01 for the axis assigned to the rotary unit. For example,

```
G01 A90. F50. ;
```

will rotate the A-Axis 90 degrees.

A feed-rate must be commanded for each line of 4 and/or 5 axis code. Limit the feed-rate to less than 75 IPM when drilling. The recommended feeds for finish machining in 3-axis work should not exceed 50 to 60 IPM with at least .0500" to .0750" stock remaining for the finish operation.

Rapid moves are not allowed; rapid motions, entering and exiting holes (full retract peck-drill cycle) are not supported.



When programming simultaneous 5-axis motion, less material allowance is required and higher feedrates may be permitted. Depending on finish allowance, length of cutter and type of profile being cut, higher feed rates may be possible. For example, when cutting mold lines or long flowing contours, feedrates may exceed 100 IPM.

## Jogging the 4th and 5th Axis

All aspects of handle jogging for the 5th axis work as they do for the other axes. The exception is the method of selecting jog between axis A and axis B.

1. Press **[+A]** or **[-A]** to select the A Axis for jogging.
2. Press **[SHIFT]**, and then press either **[+A]** or **[-A]** to jog the B Axis.
3. EC-300: Jog mode shows A1 and A2, press **[A]** to jog A1 and press **[SHIFT] [A]** to jog A2.

### 5.2.2 Installing an Optional 4th Axis

Settings 30 and 34 must be changed when adding a rotary table to a Haas mill. Setting 30 specifies the rotary table model and Setting 34 specifies the part diameter.

## Changing Setting 30

Setting 30 (and Setting 78 for the 5th axis) specifies a parameter set for a given rotary unit. These Settings allow you to select your rotary unit from a list, which then automatically sets the parameters necessary to allow your mill to interact with the rotary unit.



**WARNING:**

*Failure to match the correct brush or brushless rotary setting to the actual product being installed on the mill may cause motor damage. B in the settings denotes a brushless rotary product. Brushless indexers have two cables from the table and two connectors at the mill control for each rotary axis.*

F5.3: New Rotary File Selection Menu

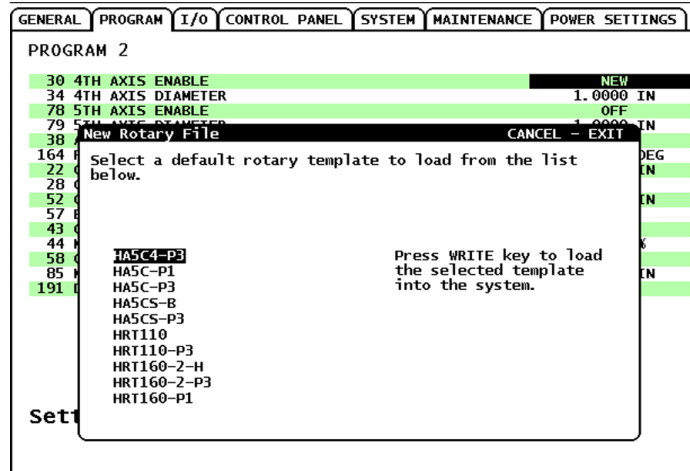

1. Highlight Setting 30 and press the left or right cursor arrow.
2. Press **[EMERGENCY STOP]**.
3. Select **NEW** and then press **[ENTER]**.  
The list of available rotary parameter sets appears.
4. Press the **[UP]** or **[DOWN]** cursor arrow to select the correct rotary unit. You can also start typing the name of the rotary unit to reduce the list before making a selection. The rotary model highlighted in the control must match the model engraved on the rotary unit's identification plate.
5. Press **[ENTER]** to confirm your choice.  
The parameter set is then loaded into the machine. The name of the current parameter set appears for Setting 30.
6. Reset **[EMERGENCY STOP]**.
7. Do not attempt to use the rotary until you cycle machine power.

## Parameters

In rare cases some parameters may need to be modified to get a specific performance out of the indexer. Do not do this without a list of parameters to change.



**NOTE:**

*DO NOT CHANGE THE PARAMETERS if you did not receive a list of parameters with the indexer. Doing so will void your warranty.*

## Initial Start-up

To start up the indexer:

1. Turn on the mill (and servo control, if applicable).
2. Home the indexer.
3. All Haas indexers home in the clockwise direction as viewed from the front. If the indexer homes counter-clockwise, press **[EMERGENCY STOP]** and call your dealer.

### 5.2.3 Installing an Optional 5th Axis

The 5th axis is installed in the same manner as the 4th axis:

1. Use Setting 78 to specify the rotary table model and 79 to define the 5th axis diameter.
2. Jog and command the 5th axis using the B address.

### 5.2.4 B on A Axis Offset (Tilting Rotary Products)

This procedure determines the distance between the plane of the B-Axis platter and the A-Axis centerline on tilting rotary products. Some CAM software applications require this offset value.

**F5.4:** B on A Offset Diagram: [1] B on A Offset, [2] A Axis, [3] B-Axis Plane.

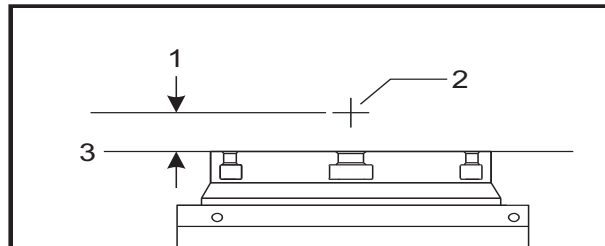

**F5.5: B on A Axis Illustrated Procedure**

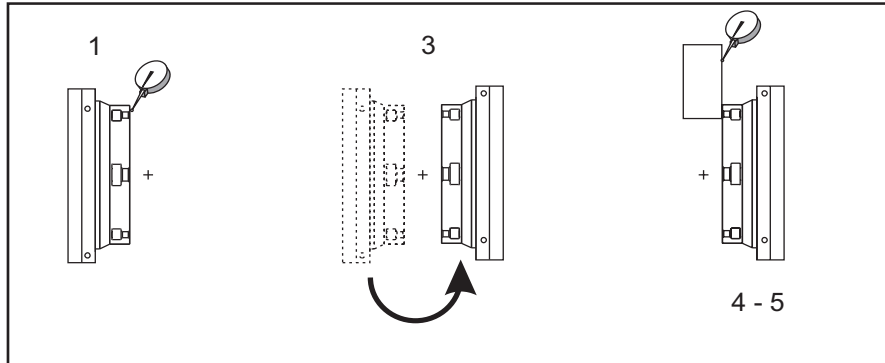

1. Rotate the A Axis until the B Axis is vertical. Mount a dial indicator on the machine spindle (or other surface independent of table motion) and indicate the platter face. Set the dial indicator to zero.
2. Set the Y Axis operator position to zero (select the position and press **[ORIGIN]**).
3. Rotate the A Axis 180°.
4. Indicate the platter face from the same direction as the first indication:
  - a. Place a 1-2-3 block against the platter face.
  - b. Indicate the face of the block that rests against the platter face.
  - c. Move the Y Axis to zero the indicator against the block.
5. Read the new Y Axis operator position. Divide this value by 2 to determine the B on A Axis offset value.

## 5.2.5 Disabling 4th and 5th Axes

To disable 4th and 5th axes:

### F5.6: Save Rotary Parameter Set

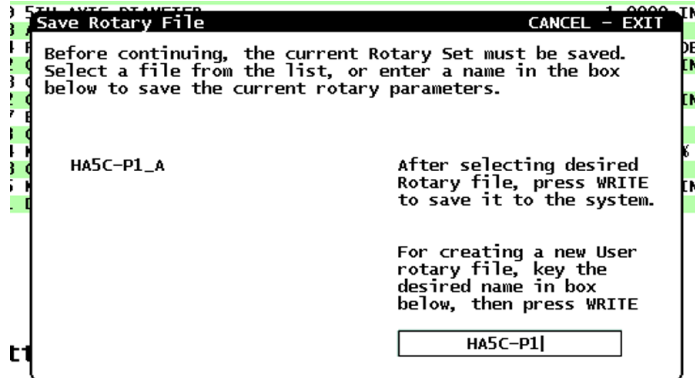

1. Turn off Setting 30 for the 4th axis and/or 78 for the 5th axis when you remove the rotary unit from the machine.  
When you turn off Setting 30 or 78, a prompt appears to save the parameter set.



#### **CAUTION:**

*Do not connect or disconnect any cables with the control on.*

2. Select a file using the up and down cursor arrows and press **[ENTER]** to confirm.  
The name of the currently selected parameter set appears in the box. You can change this filename to save a custom parameter set.
3. The machine generates an alarm if these settings are not turned off when the unit is removed.

## 5.3 Macros (Optional)

### 5.3.1 Macros Introduction



**NOTE:**

*This control feature is optional; call your dealer for information.*

Macros add capabilities and flexibility to the control that are not possible with standard G-code. Some possible uses are: families of parts, custom canned cycles, complex motions, and driving optional devices. The possibilities are almost endless.

A Macro is any routine/subprogram that may be run multiple times. A macro statement can assign a value to a variable or read a value from a variable, evaluate an expression, conditionally or unconditionally branch to another point within a program, or conditionally repeat some section of program.

Here are a few examples of the applications for Macros. The examples are outlines and not complete macro programs.

- **Tools For Immediate, On-Table Fixturing**

Many setup procedures can be semi-automated to assist the machinist. Tools can be reserved for immediate situations that were not anticipated during tool design. For instance, suppose a company uses a standard clamp with a standard bolthole pattern. If it is discovered after setup, that a fixture will need an additional clamp and if macro subroutine 2000 has been programmed for drilling the bolt pattern of the clamp, then the following two-step procedure is all that is needed for adding the clamp to the fixture:

- a) Determine X, Y, and Z coordinates and angle where the clamp is to be placed by jogging the machine to the proposed clamp position and reading the position coordinates from the machine display.
- b) Execute the following command in MDI mode:

```
G65 P2000 Xnnn Ynnn Znnn Annn ;
```

where nnn are the coordinates determined in Step a).

Here, macro 2000 ( P2000) does the work since it was designed to drill the clamp bolt hole pattern at the specified angle of A. Essentially, the machinist has created a custom canned cycle.

- **Simple Patterns That Are Repeated**

Patterns that recur over and over again can be defined using macros and stored. For example:

- a) Bolt hole patterns
- b) Slotting

- c) Angular patterns, any number of holes, at any angle, with any spacing
- d) Specialty milling such as soft jaws
- e) Matrix Patterns, (e.g. 12 across and 15 down)
- f) Fly-cutting a surface, (e.g. 12 inches by 5 inches using a 3 inch fly cutter)
- **Automatic Offset Setting Based On The Program**  
With macros, coordinate offsets can be set in each program so that setup procedures become easier and less error-prone (macro variables #2001-2800).
- **Probing**  
Using a probe enhances the capabilities of the machine, some examples are:
  - a) Profiling of a part to determine unknown dimensions for machining.
  - b) Tool calibration for offset and wear values.
  - c) Inspection prior to machining to determine material allowance on castings.
  - d) Inspection after machining to determine parallelism and flatness values as well as location.

### Useful G and M-codes

M00, M01, M30 - Stop Program  
 G04 - Dwell  
 G65 Pxx - Macro subprogram call. Allows passing of variables.  
 M96 Pxx Qxx - Conditional Local Branch when Discrete Input Signals  
 M97 Pxx - Local Sub Routine Call  
 M98 Pxx - Sub Program Call  
 M99 - Sub Program Return or Loop  
 G103 - Block Lookahead Limit. No cutter comp allowed  
 M109 - Interactive User Input (see "M-codes" section)

### Settings

There are 3 settings that can affect macro programs (9000 series programs), these are 9xxxx Progs Lock (#23), 9xxxx Progs Trace (#74) and 9xxxx Progs Single BLK (#75).

### Round Off

The control stores decimal numbers as binary values. As a result, numbers stored in variables can be off by 1 least significant digit. For example, the number 7 stored in macro variable #100 may later be read as 7.000001, 7.000000, or 6.999999. If the statement was,

```
IF [#100 EQ 7]...
```

it may give a false reading. A safer way of programming this would be,

```
IF [ROUND [#100] EQ 7]...
```

This issue is usually only a problem when storing integers in macro variables where it is expected to see a fractional part later.

### Lookahead

Lookahead is of great importance to the macro programmer. The control will attempt to process as many lines as possible ahead of time in order to speed up processing. This includes the interpretation of macro variables. For example,

```
#1101=1 ;  
G04 P1. ;  
#1101=0 ;
```

This is intended to turn an output on, wait 1 second, and then turn it off. However, lookahead will cause the output to turn on then immediately back off while the dwell is being processed. G103 P1 can be used to limit lookahead to 1 block. To make this example work properly, it must be modified as follows:

G103 P1(See the G-code section of the manual for a further explanation of G103)

```
;  
#1101=1. ;  
;  
;  
;  
#1101=0 ;
```

## Block Look Ahead and Block Delete

The Haas control uses the feature Block Look Ahead to read and prepare for blocks of code ahead of the current block of code being executed. This allows the control smoothly transition from one motion to the next. G103 Limit Block Buffering limits how far ahead the control will look at blocks of code. G103 takes the argument Pnn which specifies how far ahead the control is allowed to look ahead. For additional information, refer to the G and M-code section.

The Haas control also has the ability to skip blocks of code when the **[BLOCK DELETE]** button is pressed. To configure a block of code to be skipped in Block Delete mode, begin the line of code with a / character. Using a

```
/ M99 (Sub-Program Return) ;
```

before a block with

```
M30 (Program End and Rewind) ;
```

allows a program to be used as a program when Block Delete is on. The program is used as a sub-program when Block Delete is off.



## 5.3.2 Operation Notes

Macro variables can be saved or loaded through the RS-232 or USB port much like settings, and offsets.

### Variable Display Page

The macro variables #1 - #999 are displayed and modified through the Current Commands display.

1. Press **[CURRENT COMMANDS]** and use **[PAGE UP]/[PAGE DOWN]** to get to the **Macro Variables** page.  
As the control interprets a program, the variable changes and results are displayed on the **Macro Variables** display page.
2. The macro variable is set by entering a value and then pressing **[ENTER]**. Macro variables can be cleared by pressing **[ORIGIN]**, which will clear all variables.
3. Entering the macro variable number and pressing up or down arrow will search for that variable.
4. The variables displayed represent values of the variables during running of the program. At times, this may be up to 15 blocks ahead of actual machine actions. Debugging programs is easier when inserting a `G103 P1` at the beginning of a program to limit block buffering and then removing the `G103 P1` after debugging is completed.

5

### Display User Defined Macros 1 and 2

You can display the values of any two user-defined macros (**Macro Label 1**, **Macro Label 2**).



**NOTE:**

*The names **Macro Label 1** and **Macro Label 2** are changeable labels. just highlight the name, key in new name, and press **[ENTER]**.*

To set which two macro variables will display under **Macro Label 1** and **Macro Label 2** on the **Operation Timers & Setup** display window:

1. Press **[CURRENT COMMANDS]**.
2. Press **[PAGE UP]** or **[PAGE DOWN]** to reach the **Operation Timers & Setup** page.

3. Use arrow keys to pick the **Macro Label 1** or **Macro Label 2** entry field (to the right of the label).
4. Key in the variable number (without #) and press **[ENTER]**.

The field to the right of the entered variable number displays the current value.

## Macro Arguments

The arguments in a G65 statement are a means of sending values to and setting the local variables of a macro subroutine.

The following two tables indicate the mapping of the alphabetic address variables to the numeric variables used in a macro subroutine.

### Alphabetic Addressing

Address	Variable	Address	Variable
A	1	N	-
B	2	O	-
C	3	P	-
D	7	Q	17
E	8	R	18
F	9	S	19
G	-	T	20
H	11	U	21
I	4	V	22
J	5	W	23
K	6	X	24

Address	Variable	Address	Variable
L	-	Y	25
M	13	Z	26

Alternate Alphabetic Addressing

Address	Variable	Address	Variable	Address	Variable
A	1	K	12	J	23
B	2	I	13	K	24
C	3	J	14	I	25
I	4	K	15	J	26
J	5	I	16	K	27
K	6	J	17	I	28
I	7	K	18	J	29
J	8	I	19	K	30
K	9	J	20	I	31
I	10	K	21	J	32
J	11	I	22	K	33

Arguments accept any floating-point value to four decimal places. If the control is in metric, it will assume thousandths (.000). In example below, local variable #1 will receive .0001. If a decimal is not included in an argument value, such as:

G65, P9910, A1, B2, C3

The values are passed to macro subroutines according to the following table:

## Integer Argument Passing (no decimal point)

Address	Variable	Address	Variable	Address	Variable
A	.0001	J	.0001	S	1.
B	.0001	K	.0001	T	1.
C	.0001	L	1.	U	.0001
D	1.	M	1.	V	.0001
E	1.	N	-	W	.0001
F	1.	O	-	X	.0001
G	-	P	-	Y	.0001
H	1.	Q	.0001	Z	.0001
I	.0001	R	.0001		

All 33 local macro variables can be assigned values with arguments by using the alternate addressing method. The following example shows how one could send two sets of coordinate locations to a macro subroutine. Local variables #4 through #9 would be set to .0001 through .0006 respectively.

Example:

```
G65 P2000 I1 J2 K3 I4 J5 K6;
```

The following letters cannot be used to pass parameters to a macro subroutine: G, L, N, O or P.

## Macro Variables

There are three categories of macro variables: local, global, and system.

Macro constants are floating point values placed in a macro expression. They can be combined with addresses A-Z or they can stand alone when used within an expression. Examples of constants are .0001, 5.3 or -10.

## Local Variables

Local variables range between #1 and #33. A set of local variables is available at all times. When a call to a subroutine with a G65 command is executed, local variables are saved and a new set is available for use. This is called nesting of local variables. During a G65 call, all new local variables are cleared to undefined values and any local variables that have corresponding address variables in the G65 line are set to G65 line values. Below is a table of the local variables along with the address variable arguments that change them:

Variable	Address	Alternate	Variable	Address	Alternate
1	A		18	R	K
2	B		19	S	I
3	C		20	T	J
4	I		21	U	K
5	J		22	V	I
6	K		23	W	J
7	D	I	24	X	K
8	E	J	25	Y	I
9	F	K	26	Z	J
10		I	27		K
11	H	J	28		I
12		K	28		J
13	M	I	30		K
14		J	31		I
15		K	32		J
16		I	33		K
17	Q	J			

Variables 10, 12, 14-16 and 27-33 do not have corresponding address arguments. They can be set if a sufficient number of I, J and K arguments are used as indicated above in the section about arguments. Once in the macro subroutine, local variables can be read and modified by referencing variable numbers 1-33.

When the L argument is used to do multiple repetitions of a macro subroutine, the arguments are set only on the first repetition. This means that if local variables 1-33 are modified in the first repetition, then the next repetition will have access only to the modified values. Local values are retained from repetition to repetition when the L address is greater than 1.

Calling a subroutine via an M97 or M98 does not nest the local variables. Any local variables referenced in a subroutine called by an M98 are the same variables and values that existed prior to the M97 or M98 call.

### Global Variables

Global variables are variables that are accessible at all times. There is only one copy of each global variable. Global variables occur in three ranges: 100-199, 500-699 and 800-999. The global variables remain in memory when power is turned off.

Occasionally, there have been some macros written for factory installed options that use the global variables. For example, probing, pallet changers, etc. When using global variables, be sure they are not in use by another program on the machine.

### System Variables

System variables give the programmer the ability to interact with a variety of control conditions. By setting a system variable, the function of the control can be modified. By reading a system variable, a program can modify its behavior based on the value in the variable. Some system variables have a Read Only status; this means that the programmer cannot modify them. A brief table of currently implemented system variables follows with an explanation of their use.

Variables	Usage
#0	Not a number (read only)
#1-#33	Macro call arguments
#100-#199	General-purpose variables saved on power off
#500-#549	General-purpose variables saved on power off

<b>Variables</b>	<b>Usage</b>
#550-#580	Used by probe (if installed)
#581-#699	General-purpose variables saved on power off
#700-#749	Hidden variables for internal use only.
#800-#999	General-purpose variables saved on power off
#1000-#1063	64 discrete inputs (read only)
#1064-#1068	Maximum axis loads for X, Y, Z, A, and B-axes respectively
#1080-#1087	Raw analog to digital inputs (read only)
#1090-#1098	Filtered analog to digital inputs (read only)
#1094	Coolant Level
#1098	Spindle load with Haas vector drive (read only)
#1100-#1139	40 discrete outputs
#1140-#1155	16 extra relay outputs via multiplexed output
#1264-#1268	Maximum axis loads for C, U, V, W, and T-axes respectively
#1601-#1800	Number of Flutes of tools #1 through 200
#1801-#2000	Maximum recorded vibrations of tools 1 through 200
#2001-#2200	Tool length offsets
#2201-#2400	Tool length wear
#2401-#2600	Tool diameter/radius offsets
#2601-#2800	Tool diameter/radius wear
#3000	Programmable alarm
#3001	Millisecond timer
#3002	Hour Timer
#3003	Single block suppression



<b>Variables</b>	<b>Usage</b>
#3004	Override control
#3006	Programmable stop with message
#3011	Year, month, day
#3012	Hour, minute, second
#3020	Power on timer (read only)
#3021	Cycle start timer
#3022	Feed timer
#3023	Present part timer
#3024	Last complete part timer
#3025	Previous part timer
#3026	Tool in spindle (read only)
#3027	Spindle RPM (read only)
#3028	Number of pallet loaded on receiver
#3030	Single Block
#3031	Dry Run
#3032	Block Delete
#3033	Opt Stop
#3201-#3400	Actual Diameter for tools 1 through 200
#3401-#3600	Programmable coolant positions for tools 1 through 200
#3901	M30 count 1
#3902	M30 count 2
#4000-#4021	Previous block G-code group codes
#4101-#4126	Previous block address codes



**NOTE:**

*Mapping of 4101 to 4126 is the same as the alphabetic addressing of Macro Arguments section; e.g., the statement X1.3 sets variable #4124 to 1.3.*

VARIABLES	USAGE
#5001-#5005	Previous block end position
#5021-#5025	Present machine coordinate position
#5041-#5045	Present work coordinate position
#5061-#5069	Present skip signal position - X, Y, Z, A, B, C, U, V, W
#5081-#5085	Present tool offset
#5201-#5205	G52 Work Offsets
#5221-#5225	G54 Work Offsets
#5241-#5245	G55 Work Offsets
#5261-#5265	G56 Work Offsets
#5281-#5285	G57 Work Offsets
#5301-#5305	G58 Work Offsets
#5321-#5325	G59 Work Offsets
#5401-#5500	Tool feed timers (seconds)
#5501-#5600	Total tool timers (seconds)
#5601-#5699	Tool life monitor limit
#5701-#5800	Tool life monitor counter
#5801-#5900	Tool load monitor maximum load sensed so far
#5901-#6000	Tool load monitor limit

VARIABLES	USAGE
#6001-#6277	Settings (read only)  <b>NOTE:</b> <i>The low order bits of large values will not appear in the macro variables for settings.</i>
#6501-#6999	Parameters (read only)  <b>NOTE:</b> <i>The low order bits of large values will not appear in the macro variables for parameters.</i>

VARIABLES	USAGE
#7001-#7006 (#14001-#14006)	G110 (G154 P1) additional work offsets
#7021-#7026 (#14021-#14026)	G111 (G154 P2) additional work offsets
#7041-#7046 (#14041-#14046)	G112 (G154 P3) additional work offsets
#7061-#7066 (#14061-#14066)	G113 (G154 P4) additional work offsets
#7081-#7086 (#14081-#14086)	G114 (G154 P5) additional work offsets
#7101-#7106 (#14101-#14106)	G115 (G154 P6) additional work offsets
#7121-#7126 (#14121-#14126)	G116 (G154 P7) additional work offsets
#7141-#7146 (#14141-#14146)	G117 (G154 P8) additional work offsets
#7161-#7166 (#14161-#14166)	G118 (G154 P9) additional work offsets
#7181-#7186 (#14181-#14186)	G119 (G154 P10) additional work offsets
#7201-#7206 (#14201-#14206)	G120 (G154 P11) additional work offsets
#7221-#7226 (#14221-#14221)	G121 (G154 P12) additional work offsets
#7241-#7246 (#14241-#14246)	G122 (G154 P13) additional work offsets
#7261-#7266 (#14261-#14266)	G123 (G154 P14) additional work offsets

VARIABLES	USAGE
#7281-#7286 (#14281-#14286)	G124 (G154 P15) additional work offsets
#7301-#7306 (#14301-#14306)	G125 (G154 P16) additional work offsets
#7321-#7326 (#14321-#14326)	G126 (G154 P17) additional work offsets
#7341-#7346 (#14341-#14346)	G127 (G154 P18) additional work offsets
#7361-#7366 (#14361-#14366)	G128 (G154 P19) additional work offsets
#7381-#7386 (#14381-#14386)	G129 (G154 P20) additional work offsets
#7501-#7506	Pallet priority
#7601-#7606	Pallet status
#7701-#7706	Part program numbers assigned to pallets
#7801-#7806	Pallet usage count
#8500	Advanced Tool Management (ATM). Group ID
#8501	ATM. Percent of available tool life of all tools in the group.
#8502	ATM. Total available tool usage count in the group.
#8503	ATM. Total available tool hole count in the group.
#8504	ATM. Total available tool feed time (in seconds) in the group.
#8505	ATM. Total available tool total time (in seconds) in the group.
#8510	ATM. Next tool number to be used.
#8511	ATM. Percent of available tool life of the next tool.
#8512	ATM. Available usage count of the next tool.
#8513	ATM. Available hole count of the next tool.
#8514	ATM. Available feed time of the next tool (in seconds).
#8515	ATM. Available total time of the next tool (in seconds).
#8550	Individual tool ID

<b>VARIABLES</b>	<b>USAGE</b>
#855	Number of Flutes of tools
#8552	Maximum recorded vibrations
#8553	Tool length offsets
#8554	Tool length wear
#8555	Tool diameter offsets
#8556	Tool diameter wear
#8557	Actual diameter
#8558	Programmable coolant position
#8559	Tool feed timer (seconds)
#8560	Total tool timers (seconds)
#8561	Tool life monitor limit
#8562	Tool life monitor counter
#8563	Tool load monitor maximum load sensed so far
#8564	Tool load monitor limit
#14401-#14406	G154 P21 additional work offsets
#14421-#14426	G154 P22 additional work offsets
#14441-#14446	G154 P23 additional work offsets
#14461-#14466	G154 P24 additional work offsets
#14481-#14486	G154 P25 additional work offsets
#14501-#14506	G154 P26 additional work offsets
#14521-#14526	G154 P27 additional work offsets
#14541-#14546	G154 P28 additional work offsets
#14561-#14566	G154 P29 additional work offsets

VARIABLES	USAGE
#14581-#14586	G154 P30 additional work offsets
#14581+(20n) - #14586+(20n)	G154 P(30+n)
#15961-#15966	G154 P99 additional work offsets

### 5.3.3 System Variables In-Depth

System variables are associated with specific functions. A detailed description of these functions follows.

#### Variables #550 through #580

If the mill is equipped with a probing system, these variables are used to store probe calibration data. If these variables are overwritten, the probe will require full recalibration.

#### 1-Bit Discrete Inputs

Inputs designated as spare can be connected to external devices and used by the programmer.

#### Maximum Axis Loads

The following variables contain the maximum axis loads an axis has achieved since the machine was last powered on, or since that Macro Variable was cleared. The Maximum Axis Load is the greatest load (100.0 = 100%) an axis has seen, not the Axis Load at the time the Macro Variable is read.

#1064 = X Axis	#1264 = C axis
#1065 = Y Axis	#1265 = U axis
#1066 = Z Axis	#1266 = V axis

#1067 = A Axis	#1267 = W axis
#1068 = B Axis	#1268 = T axis

## Tool Offsets

Each tool offset has a length (H) and radius (D) along with associated wear values.

#2001-#2200	H geometry offsets (1-200) for length.
#2200-#2400	H geometry wear (1-200) for length.
#2401-#2600	D geometry offsets (1-200) for diameter.
#2601-#2800	D geometry wear (1-200) for diameter.

## Programmable Messages

#3000 Alarms can be programmed. A programmable alarm will act like the built-in alarms. An alarm is generated by setting macro variable #3000 to a number between 1 and 999.

```
#3000= 15 (MESSAGE PLACED INTO ALARM LIST) ;
```

When this is done, *Alarm* flashes at the bottom of the display and the text in the next comment is placed into the alarm list. The alarm number (in this example, 15) is added to 1000 and used as an alarm number. If an alarm is generated in this manner all motion stops and the program must be reset to continue. Programmable alarms are always numbered between 1000 and 1999. The first 34 characters of the comment are used for the alarm message.

## Timers

Two timers can be set to a value by assigning a number to the respective variable. A program can then read the variable and determine the time passed since the timer was set. Timers can be used to imitate dwell cycles, determine part-to-part time or wherever time-dependent behavior is desired.

- **#3001 Millisecond Timer** - The millisecond timer is updated every 20 milliseconds and thus activities can be timed with an accuracy of only 20 milliseconds. At Power On, the millisecond timer is reset. The timer has a limit of 497 days. The whole number returned after accessing #3001 represents the number of milliseconds.
- **#3002 Hour Timer** - The hour timer is similar to the millisecond timer except that the number returned after accessing #3002 is in hours. The hour and millisecond timers are independent of each other and can be set separately.

## System Overrides

**#3003 Variable** is the Single Block Suppression parameter. It overrides the Single Block function in G-code. In the following example Single Block is ignored when #3003 is set equal to 1. After #3003 is set =1, each G-code command (lines 2-5) is executed continuously even though the Single Block function is ON. When #3003 is set equal to zero, Single Block will operate as normal. The user must press **[CYCLE START]** to execute each line of code (lines 7-11).

```
#3003=1 ;
G54 G00 G90 X0 Y0 ;
S2000 M03 ;
G43 H01 Z.1 ;
G81 R.1 Z-0.1 F20. ;
#3003=0 ;
T02 M06 ;
G43 H02 Z.1 ;
S1800 M03 ;
G83 R.1 Z-1. Q.25 F10. ;
X0. Y0. ;
```

## Variable #3004

Variable #3004 overrides specific control features while running.

The first bit disables **[FEED HOLD]**. If **[FEED HOLD]** is not used during a section of code, set variable #3004 to 1 before the specific lines of code. After that section of code set #3004 to 0 to restore the function of **[FEED HOLD]**. For example:

```
(Approach code - [FEED HOLD] allowed) ;  
#3004=1 (Disables [FEED HOLD]) ;  
(Non-stoppable code - [FEED HOLD] not allowed) ;  
#3004=0 (Enables [FEED HOLD]) ;  
(Depart code - [FEED HOLD] allowed) ;
```

The following is a map of variable #3004 bits and the associated overrides. E – Enabled D – Disabled

#3004	Feed Hold	Feed Rate Override	Exact Stop Check
0	E	E	E
1	D	E	E
2	E	D	E
3	D	D	E
4	E	E	D
5	D	E	D
6	E	D	D
7	D	D	D

### #3006 Programmable Stop

Stops can be programmed to act like an M00 - The control stops and waits until **[CYCLE START]** is pressed. Once **[CYCLE START]** is pressed, the program continues with the block after the #3006. In the following example, the first 15 characters of the comment are displayed on the lower left part of the screen.

```
IF [#1 EQ #0] THEN #3006=101 (comment here) ;
```



## #4001-#4021 Last Block (Modal) Group Codes

The grouping of G codes permits more efficient processing. G codes with similar functions are usually under the same group. For example, G90 and G91 are under group 3. These variables store the last or default G code for any of 21 groups. By reading the group code, a macro program can change the behavior of the G-code. If #4003 contains 91, then a macro program could determine that all moves should be incremental rather than absolute. There is no associated variable for group zero; group zero G codes are Non-modal.

## #4101-#4126 Last Block (Modal) Address Data

Address codes A-Z (excluding G) are maintained as modal values. The information represented by the last line of code interpreted by the lookahead process is contained in variables #4101 through #4126. The numeric mapping of variable numbers to alphabetic addresses corresponds to the mapping under alphabetic addresses. For example, the value of the previously interpreted D address is found in #4107 and the last interpreted I value is #4104. When aliasing a macro to an M-code, you may not pass variables to the macro using variables #1-#33; instead, use the values from #4101-#4126 in the macro.

## #5001-#5006 Last Target Position

The final programmed point for the last motion block can be accessed through variables #5001-#5006, X, Y, Z, A, B, and C, respectively. Values are given in the current work coordinate system and can be used while the machine is in motion.

## Axis Position Variables

#5021 X-Axis	#5022 Y-Axis	#5023 Z-Axis
#5024 A-Axis	#5025 B-Axis	#5026 C-axis

## #5021-#5026 Current Machine Coordinate Position

The current position in machine coordinates can be obtained through #5021-#5026 corresponding to axis X, Y, Z, A, B, and C, respectively.



**NOTE:**

*Values CANNOT be read while machine is in motion.*

Value of #5023 (Z) has tool length compensation applied to it.

## #5041-#5046 Current Work Coordinate Position

The current position in the current work coordinates can be obtained through #5041-#5045 corresponding to axis X, Y, Z, A, B, and C, respectively.



**NOTE:**

*The values CANNOT be read while the machine is in motion.*

The value of #5043 (Z) has tool length compensation applied to it.

## #5061-#5069 Current Skip Signal Position

The position where the last skip signal was triggered can be obtained through #5061-#5069 corresponding to X, Y, Z, A, B, C, U, V and W respectively. Values are given in the current work coordinate system and can be used while the machine is in motion. The value of #5063 (Z) has tool length compensation applied to it.

## #5081-#5085 Tool Length Compensation

The current total tool length compensation that is being applied to the tool. This includes tool length offset referenced by the current value set in H (#4008) plus the wear value.



**NOTE:**

*The mapping of the axes are x=1, y=2, ... b=5. So as an example, the Z machine coordinate system variable would be #5023.*

## #6996-#6999 Parameter Access Using Macro Variables

It is possible for a program to access parameters 1 to 1000 and any of the parameter bits, as follows:

#6996: Parameter Number

#6997: Bit Number (optional)

#6998: Contains value of parameter number in variable #6996

#6999: Contains bit value (0 or 1) of parameter bit specified in variable #6997.



**NOTE:**

*Variables #6998 and #6999 are read-only.*

### Usage

To access the value of a parameter, the number of that parameter is copied into variable #6996, after which, the value of that parameter is available using macro variable #6998, as shown:

```
#6996=601 (Specify parameter 601) ;
#100=#6998 (Copy the value of parameter 601 to variable #100)
;
```

To access a specific parameter bit, parameter number is copied into variable 6996 and the bit number is copied to macro variable 6997. The value of that parameter bit is available using macro variable 6999, as shown:

```
#6996=57 (Specify parameter 57) ;
#6997=0 (Specify bit zero) ;
#100=#6999 (Copy parameter 57 bit 0 to variable #100) ;
```



**NOTE:**

*Parameter bits are numbered 0 through 31. 32-bit parameters are formatted, on-screen, with bit 0 at the top-left, and bit 31 at the bottom-right.*

## Pallet Changer

The status of the pallets, from the Automatic Pallet Changer are checked using the following variables:

#7501-#7506	Pallet priority
#7601-#7606	Pallet status
#7701-#7706	Part program numbers assigned to pallets
#7801-#7806	Pallet usage count
#3028	Number of pallet loaded on receiver

## Work Offsets

All work offsets can be read and set within a macro expression to allow the coordinates to be preset to approximate locations, or set coordinates to values based upon results of skip signal locations and calculations. When any of offsets are read, the interpretation lookahead queue is stopped until that block is executed.

#5201- #5206	G52 X, Y, Z, A, B, C OFFSET VALUES
#5221- #5226	G54 X, Y, Z, A, B, C OFFSET VALUES
#5241- #5246	G55 X, Y, Z, A, B, C OFFSET VALUES
#5261- #5266	G56 X, Y, Z, A, B, C OFFSET VALUES
#5281- #5286	G57 X, Y, Z, A, B, C OFFSET VALUES
#5301- #5306	G58 X, Y, Z, A, B, C OFFSET VALUES
#5321- #5326	G59X, Y, Z, A, B, C OFFSET VALUES
#7001- #7006	G110 X, Y, Z, A, B, C OFFSET VALUES
#7021-#7026 (#14021-#14026)	G111 (G154 P2) additional work offsets

#7041-#7046 (#14041-#14046)	G112 (G154 P3) <b>additional work offsets</b>
#7061-#7066 (#14061-#14066)	G113 (G154 P4) <b>additional work offsets</b>
#7081-#7086 (#14081-#14086)	G114 (G154 P5) <b>additional work offsets</b>
#7101-#7106 (#14101-#14106)	G115 (G154 P6) <b>additional work offsets</b>
#7121-#7126 (#14121-#14126)	G116 (G154 P7) <b>additional work offsets</b>
#7141-#7146 (#14141-#14146)	G117 (G154 P8) <b>additional work offsets</b>
#7161-#7166 (#14161-#14166)	G118 (G154 P9) <b>additional work offsets</b>
#7181-#7186 (#14181-#14186)	G119 (G154 P10) <b>additional work offsets</b>
#7201-#7206 (#14201-#14206)	G120 (G154 P11) <b>additional work offsets</b>
#7221-#7226 (#14221-#14221)	G121 (G154 P12) <b>additional work offsets</b>
#7241-#7246 (#14241-#14246)	G122 (G154 P13) <b>additional work offsets</b>
#7261-#7266 (#14261-#14266)	G123 (G154 P14) <b>additional work offsets</b>
#7281-#7286 (#14281-#14286)	G124 (G154 P15) <b>additional work offsets</b>
#7301-#7306 (#14301-#14306)	G125 (G154 P16) <b>additional work offsets</b>
#7321-#7326 (#14321-#14326)	G126 (G154 P17) <b>additional work offsets</b>
#7341-#7346 (#14341-#14346)	G127 (G154 P18) <b>additional work offsets</b>

#7361-#7366 (#14361-#14366)	G128 (G154 P19) additional work offsets
#7381-#7386 (#14381-#14386)	G129 (G154 P20) additional work offsets
#7381- #7386	G129 X, Y, Z, A, B, C OFFSET VALUES

### #8550-#8567

These variables provide information on tooling. Set variable #8550 to the tool or tool group number, then access information for the selected tool/tool group using the read-only macros #8551-#8564. If specifying a tool group number, the selected tool will be the next tool in that group.

## 5.3.4 Variable Usage

All variables are referenced with a pound sign (#) followed by a positive number: #1, #101, and #501.

Variables are decimal values that are represented as floating point numbers. If a variable has never been used, it can take on a special **undefined** value. This indicates that it has not been used. A variable can be set to **undefined** with the special variable #0. #0 has the value of undefined or 0.0 depending on its context. Indirect references to variables can be accomplished by enclosing the variable number in brackets: # [<Expression>]

The expression is evaluated and the result becomes the variable accessed. For example:

```
#1=3 ;  
#[#1]=3.5 + #1 ;
```

This sets the variable #3 to the value 6.5.

A variable can be used in place of a G-code address where address refers to the letters A-Z.

In the block:

```
N1 G0 G90 X1.0 Y0 ;
```

the variables can be set to the following values:

```
#7=0 ;  
#11=90 ;  
#1=1.0 ;  
#2=0.0 ;
```

and replaced by:

```
N1 G#7 G#11 X#1 Y#2 ;
```

Values in the variables at runtime are used as the address values.

### 5.3.5 Address Substitution

The usual method of setting control addresses A-Z is the address followed by a number. For example:

```
G01 X1.5 Y3.7 F20.;
```

sets addresses G, X, Y and F to 1, 1.5, 3.7 and 20.0 respectively and thus instructs the control to move linearly, G01, to position X=1.5 Y=3.7 at a feed rate of 20" per minute. Macro syntax allows the address values to be replaced with any variable or expression.

The previous statement can be replaced by the following code:

```
#1=1 ;
#2=1.5 ;
#3=3.7 ;
#4=20 ;
G#1 X[#1+#2] Y#3 F#4 ;
```

The permissible syntax on addresses A-Z (exclude N or O) is as follows:

<address><-><variable>	A-#101
<address>[<expression>]	Y[#5041+3.5]
<address><->[<expression>]	Z-[SIN[#1]]

If the variable value does not agree with the address range, the control will generate an alarm. For example, the following code would result in a range error alarm because tool diameter numbers range from 0-200.

```
#1=250 ;
D#1 ;
```

When a variable or expression is used in place of an address value, the value is rounded to the least significant digit. If #1=.123456, then G1X#1 would move the machine tool to .1235 on the X Axis. If the control is in the metric mode, the machine would be moved to .123 on the X axis.

When an undefined variable is used to replace an address value, then that address reference is ignored. For example, if #1 is undefined, then the block

```
G00 X1.0 Y#1 ;
```

becomes

```
G00 X1.0 ;
```

and no Y movement takes place.

## Macro Statements

Macro statements are lines of code that allow the programmer to manipulate the control with features similar to any standard programming language. Included are functions, operators, conditional and arithmetic expressions, assignment statements, and control statements.

Functions and operators are used in expressions to modify variables or values. The operators are essential to expressions while functions make the programmer's job easier.

## Functions

Functions are built-in routines that the programmer has available to use. All functions have the form <function\_name>[argument] and return floating-point decimal values. The functions provided in the Haas control are as follows:

Function	Argument	Returns	Notes
SIN[ ]	Degrees	Decimal	Sine
COS[ ]	Degrees	Decimal	Cosine
TAN[ ]	Degrees	Decimal	Tangent
ATAN[ ]	Decimal	Degrees	Arctangent Same as FANUC ATAN[ ]/[1]
SQRT[ ]	Decimal	Decimal	Square root
ABS[ ]	Decimal	Decimal	Absolute value
ROUND[ ]	Decimal	Decimal	Round off a decimal
FIX[ ]	Decimal	Integer	Truncate fraction
ACOS[ ]	Decimal	Degrees	Arc cosine



Function	Argument	Returns	Notes
ASIN[ ]	Decimal	Degrees	Arcsine
#[ ]	Integer	Integer	Variable Indirection
DPRNT[ ]	ASCII text	External Output	

## Notes on Functions

The function `ROUND` works differently depending on the context that it is used. When used in arithmetic expressions, any number with a fractional part greater than or equal to `.5` is rounded up to the next whole integer; otherwise, the fractional part is truncated from the number.

```
#1= 1.714 ;
#2= ROUND[#1] (#2 is set to 2.0) ;
#1= 3.1416 ;
#2= ROUND[#1] (#2 is set to 3.0) ;
```

When `round` is used in an address expression, `ROUND` is rounded to the significant precision. For metric and angle dimensions, three-place precision is the default. For inch, four-place precision is the default.

```
#1= 1.00333 ;
G0 X[ #1 + #1 ] ;
(Table moves to 2.0067) ;
G0 X[ ROUND[ #1 ] + ROUND[ #1 ] ] ;
(Table moves to 2.0066) ;
G0 A[ #1 + #1 ] ;
(Axis moves to 2.007) ;
G0 A[ ROUND[ #1 ] + ROUND[ #1 ] ] ;
(Axis moves to 2.006) ;
D[1.67] (Diameter 2 is made current) ;
```

## Fix vs. Round

```
#1=3.54 ;
#2=ROUND[#1] ;
#3=FIX[#1].
```

#2 will be set to 4. #3 will be set to 3.

## Operators

Operators can be classified into three categories: Arithmetic, Logical and Boolean.

### Arithmetic Operators

Arithmetic operators consist of unary and binary operators. They are:

+	- Unary plus	+1.23
-	- Unary minus	-[COS[30]]
+	- Binary addition	#1=#1+5
-	- Binary subtraction	#1=#1-1
*	- Multiplication	#1=#2*#3
/	- Division	#1=#2/4
MOD	- Remainder	#1=27 MOD 20 (#1 contains 7)

### Logical Operators

Logical operators are operators that work on binary bit values. Macro variables are floating point numbers. When logical operators are used on macro variables, only the integer portion of the floating point number is used. The logical operators are:

OR - logically OR two values together

XOR - Exclusively OR two values together

AND - Logically AND two values together

Examples:

```
#1=1.0 ;  
#2=2.0 ;  
#3=#1 OR #2 ;
```

Here the variable #3 will contain 3.0 after the OR operation.

```
#1=5.0 ;  
#2=3.0 ;
```

```
IF [[#1 GT 3.0] AND [#2 LT 10]] GOTO1 ;
```

Here control will transfer to block 1 because #1 GT 3.0 evaluates to 1.0 and #2 LT 10 evaluates to 1.0, thus 1.0 AND 1.0 is 1.0 (TRUE) and the GOTO occurs.

**NOTE:**

*Care must be taken when using logical operators so that the desired result is achieved.*

## Boolean Operators

Boolean operators always evaluate to 1.0 (TRUE) or 0.0 (FALSE). There are six Boolean operators. These operators are not restricted to conditional expressions, but they most often are used in conditional expressions. They are:

EQ - Equal To

NE - Not Equal To

GT - Greater Than

LT - Less Than

GE - Greater Than or Equal To

LE - Less Than or Equal To

The following are four examples of how Boolean and Logical operators can be used:

Example	Explanation
IF [#1 EQ 0.0] GOTO100 ;	Jump to block 100 if value in variable #1 equals 0.0.
WHILE [#101 LT 10] DO1 ;	While variable #101 is less than 10 repeat loop DO1..END1.
#1=[1.0 LT 5.0] ;	Variable #1 is set to 1.0 (TRUE).
IF [#1 AND #2 EQ #3] GOTO1 ;	If variable #1 AND variable #2 are equal to the value in #3 then control jumps to block 1.

## Expressions

Expressions are defined as any sequence of variables and operators surrounded by the square brackets [ and ]. There are two uses for expressions: conditional expressions or arithmetic expressions. Conditional expressions return FALSE (0.0) or TRUE (any non zero) values. Arithmetic expressions use arithmetic operators along with functions to determine a value.

### Conditional Expressions

In the Haas control, all expressions set a conditional value. The value is either 0.0 (FALSE) or the value is nonzero (TRUE). The context in which the expression is used determines if the expression is a conditional expression. Conditional expressions are used in the IF and WHILE statements and in the M99 command. Conditional expressions can make use of Boolean operators to help evaluate a TRUE or FALSE condition.

The M99 conditional construct is unique to the Haas control. Without macros, M99 in the Haas control has the ability to branch unconditionally to any line in the current subroutine by placing a P code on the same line. For example:

```
N50 M99 P10 ;
```

branches to line N10. It does not return control to the calling subroutine. With macros enabled, M99 can be used with a conditional expression to branch conditionally. To branch when variable #100 is less than 10 we could code the above line as follows:

```
N50 [#100 LT 10] M99 P10 ;
```

In this case, the branch occurs only when #100 is less than 10, otherwise processing continues with the next program line in sequence. In the above, the conditional M99 can be replaced with

```
N50 IF [#100 LT 10] GOTO10 ;
```

### Arithmetic Expressions

An arithmetic expression is any expression using variables, operators, or functions. An arithmetic expression returns a value. Arithmetic expressions are usually used in assignment statements, but are not restricted to them.

Examples of Arithmetic expressions:

```
#101=#145*#30 ;  
#1=#1+1 ;  
X[#105+COS[#101]] ;  
#[#2000+#13]=0 ;
```

## Assignment Statements

Assignment statements allow the programmer to modify variables. The format of the assignment statement is:

```
<expression>=<expression>
```

The expression on the left of the equal sign must always refer to a macro variable, whether directly or indirectly. The following macro initializes a sequence of variables to any value. Here both direct and indirect assignments are used.

```
O0300 (Initialize an array of variables) ;
N1 IF [#2 NE #0] GOTO2 (B=base variable) ;
#3000=1 (Base variable not given) ;
N2 IF [#19 NE #0] GOTO3 (S=size of array) ;
#3000=2 (Size of array not given) ;
N3 WHILE [#19 GT 0] DO1 ;
#19=#19-1 (Decrement count) ;
#[#2+#19]=#22 (V=value to set array to) ;
END1 ;
M99 ;
```

The above macro could be used to initialize three sets of variables as follows:

```
G65 P300 B101. S20 (INIT 101..120 TO #0) ;
G65 P300 B501. S5 V1. (INIT 501..505 TO 1.0) ;
G65 P300 B550. S5 V0 (INIT 550..554 TO 0.0) ;
```

The decimal point in B101., etc. would be required.

## Control Statements

Control statements allow the programmer to branch, both conditionally and unconditionally. They also provide the ability to iterate a section of code based on a condition.

### Unconditional Branch (GOTO<sub>nnn</sub> and M99 P<sub>nnnn</sub>)

In the Haas control, there are two methods of branching unconditionally. An unconditional branch will always branch to a specified block. M99 P15 will branch unconditionally to block number 15. The M99 can be used whether or not macros is installed and is the traditional method for branching unconditionally in the Haas control. GOTO15 does the same as M99 P15. In the Haas control, a GOTO command can be used on the same line as other G-codes. The GOTO is executed after any other commands like M codes.

## Computed Branch (GOTO#n and GOTO [expression])

Computed branching allows the program to transfer control to another line of code in the same subprogram. The block can be computed as the program is running, using the `GOTO [expression]` form. Or the block can be passed in through a local variable, as in the `GOTO#n` form.

The `GOTO` will round the variable or expression result that is associated with the Computed branch. For instance, if `#1` contains 4.49 and `GOTO#1` is executed, the control will attempt to transfer to a block containing `N4`. If `#1` contains 4.5, then execution will transfer to a block containing `N5`.

The following code skeleton could be developed to make a program that adds serial numbers to parts:

```
O9200 (Engrave digit at current location) ;
      (D=Decimal digit to engrave) ;
      ;
      IF [[#7 NE #0] AND [#7 GE 0] AND [#7 LE 9]] GOTO99 ;
      #3000=1 (Invalid digit) ;
      ;
      N99
      #7=FIX[#7] (Truncate any fractional part) ;
      ;
      GOTO#7 (Now engrave the digit) ;
      ;
      N0 (Do digit zero) ;
      M99 ;
      ;
      N1 (Do digit one) ;
      ;
      M99 ;
      ;
      N2 (Do digit two) ;
      ;
      ...
      ;
      (etc.,...)
```

With the above subroutine, you would engrave digit five with the following call:

```
G65 P9200 D5 ;
```

Computed `GOTOS` using expression could be used to branch processing based on the results of reading hardware inputs. An example might look like the following:

```
GOTO [[#1030*2]+#1031] ;
NO(1030=0, 1031=0) ;
...
```

```

M99 ;
N1(1030=0, 1031=1) ;
...
M99 ;
N2(1030=1, 1031=0) ;
...
M99 ;
N3(1030=1, 1031=1) ;
...
M99 ;

```

The discrete inputs always return either 0 or 1 when read. The `GOTO [expression]` will branch to the appropriate line of code based on the state of the two discrete inputs #1030 and #1031.

## Conditional Branch (IF and M99 Pnnnn)

Conditional branching allows the program to transfer control to another section of code within the same subroutine. Conditional branching can only be used when macros are enabled. The Haas control allows two similar methods for accomplishing conditional branching:

```
IF [<conditional expression>] GOTO n
```

As discussed, <conditional expression> is any expression that uses any of the six Boolean operators `EQ`, `NE`, `GT`, `LT`, `GE`, or `LE`. The brackets surrounding the expression are mandatory. In the Haas control, it is not necessary to include these operators. For example:

```
IF [#1 NE 0.0] GOTO5 ;
```

could also be:

```
IF [#1] GOTO5 ;
```

In this statement, if the variable #1 contains anything but 0.0, or the undefined value #0, then branching to block 5 occurs; otherwise, the next block is executed.

In the Haas control, a <conditional expression> is also used with the `M99 Pnnnn` format. For example:

```
G00 X0 Y0 [#1EQ#2] M99 P5;
```

Here, the conditional is for the `M99` portion of the statement only. The machine tool is instructed to go to `X0`, `Y0` whether or not the expression evaluates to True or False. Only the branch, `M99`, is executed based on the value of the expression. It is recommended that the `IF GOTO` version be used if portability is desired.

## Conditional Execution (IF THEN)

Execution of control statements can also be achieved by using the `IF THEN` construct. The format is:

```
IF [<conditional expression>] THEN <statement> ;
```



**NOTE:**

*To preserve compatibility with FANUC syntax `THEN` may not be used with `GOTO`n.*

This format is traditionally used for conditional assignment statements such as:

```
IF [#590 GT 100] THEN #590=0.0 ;
```

Variable #590 is set to zero when the value of #590 exceeds 100.0. In the Haas control, if a conditional evaluates to FALSE (0.0), then the remainder of the `IF` block is ignored. This means that control statements can also be conditioned so that we could write something like:

```
IF [#1 NE #0] THEN G01 X#24 Y#26 F#9 ;
```

This executes a linear motion only if variable #1 has been assigned a value. Another example is:

```
IF [#1 GE 180] THEN #101=0.0 M99 ;
```

This says that if variable #1 (address A) is greater than or equal to 180, then set variable #101 to zero and return from the subroutine.

Here is an example of an `IF` statement that branches if a variable has been initialized to contain any value. Otherwise, processing continues and an alarm is generated. Remember, when an alarm is generated, program execution is halted.

```
N1 IF [#9NE#0] GOTO3 (TEST FOR VALUE IN F) ;  
N2 #3000=11(NO FEED RATE) ;  
N3 (CONTINUE) ;
```

## Iteration/Looping (WHILE DO END)

Essential to all programming languages is the ability to execute a sequence of statements a given number of times or to loop through a sequence of statements until a condition is met. Traditional G coding allows this with the use of the `L` address. A subroutine can be executed any number of times by using the `L` address.

```
M98 P2000 L5 ;
```



This is limited since you cannot terminate execution of the subroutine on condition. Macros allow flexibility with the WHILE-DO-END construct. For example:

```
WHILE [<conditional expression>] DO n ;
<statements> ;
END n ;
```

This executes the statements between DO n and END n as long as the conditional expression evaluates to True. The brackets in the expression are necessary. If the expression evaluates to False, then the block after END n is executed next. WHILE can be abbreviated to WH. The DO n-END n portion of the statement is a matched pair. The value of n is 1-3. This means that there can be no more than three nested loops per subroutine. A nest is a loop within a loop.

Although nesting of WHILE statements can only be up to three levels, there really is no limit since each subroutine can have up to three levels of nesting. If there is a need to nest to a level greater than 3, then the segment containing the three lowest levels of nesting can be made into a subroutine thus overcoming the limitation.

If two separate WHILE loops are in a subroutine, they can use the same nesting index. For example:

```
#3001=0 (WAIT 500 MILLISECONDS) ;
WH [#3001 LT 500] DO 1 ;
END 1 ;
<Other statements>
#3001=0 (WAIT 300 MILLISECONDS) ;
WH [#3001 LT 300] DO 1 ;
END 1 ;
```

You can use GOTO to jump out of a region encompassed by a DO-END, but you cannot use a GOTO to jump into it. Jumping around inside a DO-END region using a GOTO is allowed.

An infinite loop can be executed by eliminating the WHILE and expression. Thus,

```
DO 1 ;
<statements>
END 1 ;
```

executes until the RESET key is pressed.



**CAUTION:**

*The following code can be confusing:*

```
WH [#1] DO 1 ;
END 1 ;
```

In this example, an alarm results indicating no Then was found; Then refers to the D01. Change D01 (zero) to DO1 (letter O).

### 5.3.6 G65 Macro Subroutine Call Option (Group 00)

G65 is the command that calls a subroutine with the ability to pass arguments to it. The format follows:

```
G65 Pnnnn [Lnnnn] [arguments] ;
```

Arguments italicized in square brackets are optional. See the Programming section for more details on macro arguments.

The G65 command requires a P address corresponding to a program number currently in the control's memory. When the L address is used the macro call is repeated the specified number of times.

In Example 1, subroutine 1000 is called once without conditions passed to the subroutine. G65 calls are similar to, but not the same as, M98 calls. G65 calls can be nested up to 9 times, which means, program 1 can call program 2, program 2 can call program 3 and program 3 can call program 4.

Example 1:

```
G65 P1000 (Call subroutine 1000 as a macro) ;  
M30 (Program stop) ;  
O1000 (Macro Subroutine) ;  
...  
M99 (Return from Macro Subroutine) ;
```

In Example 2, subroutine 9010 is designed to drill a sequence of holes along a line whose slope is determined by the X and Y arguments that are passed to it in the G65 command line. The Z drill depth is passed as Z, the feed rate is passed as F, and the number of holes to be drilled is passed as T. The line of holes is drilled starting from the current tool position when the macro subroutine is called.

Example 2:

```
G00 G90 X1.0 Y1.0 Z.05 S1000 M03 (Position tool) ;  
G65 P9010 X.5 Y.25 Z.05 F10. T10 (Call 9010) ;  
G28 ;  
M30 ;  
O9010 (Diagonal hole pattern) ;  
F#9 (F=Feedrate) ;  
WHILE [#20 GT 0] DO1 (Repeat T times) ;  
G91 G81 Z#26 (Drill To Z depth) ;  
#20=#20-1 (Decrement counter) ;  
IF [#20 EQ 0] GOTO5 (All holes drilled) ;  
G00 X#24 Y#25 (Move along slope) ;  
N5 END1 ;  
M99 (Return to caller) ;
```

## Aliasing

Aliased codes are user defined G and M-codes that reference a macro program. There are 10 G alias codes and 10 M alias codes available to users.

Aliasing is a means of assigning a G-code or M-code to a G65 P##### sequence. For instance, in Example 2, it would be easier to write:

```
G06 X.5 Y.25 Z.05 F10. T10 ;
```

When aliasing, variables can be passed with a G-code; variables cannot be passed with an M-code.

Here, an unused G code has been substituted, G06 for G65 P9010. In order for the previous block to work, the parameter associated with subroutine 9010 must be set to 06 (Parameter 91).



**NOTE:**

*G00, G65, G66, and G67 cannot be aliased. All other codes between 1 and 255 can be used for aliasing.*

Program numbers 9010 through 9019 are reserved for G code aliasing. The following table lists which Haas parameters are reserved for macro subroutine aliasing.

**F5.7:** G- and M-code Aliasing

Haas Parameter	O Code	Haas Parameter	O Code
91	9010	81	9000
92	9011	82	9001
93	9012	83	9002
94	9013	84	9003
95	9014	85	9004
96	9015	86	9005
97	9016	87	9006
98	9017	88	9007
99	9018	89	9008
100	9019	90	9009

Setting an aliasing parameter to 0 disables aliasing for the associated subroutine. If an aliasing parameter is set to a G-code and the associated subroutine is not in memory, then an alarm will be given. When a G65 macro, Aliased-M or Aliased-G code is called, the control first looks for the sub-program in **MEM**. If it is not found in **MEM**, the control then looks for the sub-program on the active drive (**USB**, **HDD**). An alarm occurs if the sub-program is not found.

When a G65 macro, Aliased-M or Aliased-G code is called, the control looks for the sub-program in memory and then in any other active drive if the sub-program cannot be located. The active drive may be memory, USB drive or hard drive. An alarm occurs if the control does not find the sub-program in either memory or an active drive.

### 5.3.7 Communication With External Devices - DPRNT[ ]

Macros allow additional capabilities to communicate with peripheral devices. With user provided devices you can digitize parts, provide runtime inspection reports, or synchronize controls. The commands provided for this are `POPEN`, `DPRNT[ ]` and `PCLOS`.

### Communication Preparatory Commands

`POPEN` and `PCLOS` are not required on the Haas machine. It has been included so that programs from different controls can be sent to the Haas control.

### Formatted Output

The `DPRNT` statement allows the programmer to send formatted text to the serial port. Any text and any variable can be printed to the serial port. The form of the `DPRNT` statement is as follows:

```
DPRNT [<text> <#nnnn[wf]>... ] ;
```

`DPRNT` must be the only command in the block. In the previous example, `<text>` is any character from A to Z or the letters (+, -, /, \*, and the space). When an asterisk is output, it is converted to a space. The `<#nnnn[wf]>` is a variable followed by a format. The variable number can be any macro variable. The format `[wf]` is required and consists of two digits within square brackets. Remember that macro variables are real numbers with a whole part and a fractional part. The first digit in the format designates the total places reserved in the output for the whole part. The second digit designates the total places reserved for the fractional part. The total places reserved for output cannot be equal to zero or greater than eight. Thus the following formats are illegal: `[00]` `[54]` `[45]` `[36]` /\* not legal formats \*/

A decimal point is printed out between the whole part and the fractional part. The fractional part is rounded to the least significant place. When zero places are reserved for the fractional part, then no decimal point is printed out. Trailing zeros are printed if there is a fractional part. At least one place is reserved for the whole part, even when a zero is used. If the value of the whole part has fewer digits than have been reserved, then leading spaces are output. If the value of the whole part has more digits than has been reserved, then the field is expanded so that these numbers are printed.

A carriage return is sent out after every `DPRNT` block.

## DPRNT[] Examples

Code	Output
N1 #1= 1.5436 ;	
N2 DPRNT[X#1[44]*Z#1[03]*T#1[40]] ;	X1.5436 Z 1.544 T 1
N3 DPRNT[***MEASURED*INSIDE*DIAMETER***] ;	MEASURED INSIDE DIAMETER
N4 DPRNT[] ;	(no text, only a carriage return)
N5 #1=123.456789 ;	
N6 DPRNT[X-#1[35]] ;	X-123.45679 ;

## Execution

DPRNT statements are executed at block interpretation time. This means that the programmer must be careful about where the DPRNT statements appear in the program, particularly if the intent is to print out.

G103 is useful for limiting lookahead. If you wanted to limit lookahead interpretation to one block, you would include the following command at the beginning of your program: (This actually results in a two block lookahead.)

```
G103 P1 ;
```

To cancel the lookahead limit, change the command to G103 P0. G103 cannot be used when cutter compensation is active.

## Editing

Improperly structured or improperly placed macro statements will generate an alarm. Be careful when editing expressions; brackets must be balanced.

The DPRNT[ ] function can be edited much like a comment. It can be deleted, moved as a whole item, or individual items within the bracket can be edited. Variable references and format expressions must be altered as a whole entity. If you wanted to change [24] to [44], place the cursor so that [24] is highlighted, enter [44] and press **[ENTER]**. Remember, you can use the **[HANDLE JOG]** control to maneuver through long DPRNT[ ] expressions.

Addresses with expressions can be somewhat confusing. In this case, the alphabetic address stands alone. For instance, the following block contains an address expression in X:

```
G1 G90 X [COS [90]] Y3.0 (CORRECT) ;
```

Here, the X and brackets stand-alone and are individually editable items. It is possible, through editing, to delete the entire expression and replace it with a floating-point constant.

```
G1 G90 X 0 Y3.0 (WRONG) ;
```

The above block will result in an alarm at runtime. The correct form looks as follows:

```
G1 G90 X0 Y3.0 (CORRECT) ;
```



**NOTE:**

*There is no space between the X and the Zero (0). REMEMBER when you see an alpha character standing alone it is an address expression.*

## 5.4 Fanuc-Style Macros Not Included

This section lists the FANUC macro features that are not available on the Haas control.

M Aliasing Replace G65 Pnnnn with Mnn PROGS 9020-9029.

G66	Modal call in every motion block
G66.1	Modal call in every motion block
G67	Modal cancel
M98	Aliasing, T code PROG 9000, VAR #149, enable bit
M98	Aliasing, B Code PROG 9028, VAR #146, enable bit

SKIP/N	N=1..9
#3007	Mirror image on flag each axis
#4201-#4320	Current block modal data
#5101-#5106	Current servo deviation

Names for Variables for Display Purposes:

ATAN [ ]/[ ]	Arctangent, FANUC version
BIN [ ]	Conversion from BCD TO BIN
BCD [ ]	Conversion from BIN TO BCD
FUP [ ]	Truncate fraction ceiling
LN [ ]	Natural logarithm
EXP [ ]	Base E Exponentiation
ADP [ ]	Re-Scale variable to whole number
BPRNT [ ]	

GOTO-nnnn

Searching for a block to jump in the negative direction, i.e. backwards through a program, is not necessary if you use unique N address codes.

A block search is made starting from the current block being interpreted. When the end of the program is reached, searching continues from the top of the program until the current block is encountered.

## 5.5 Programmable Coolant (P-Cool)

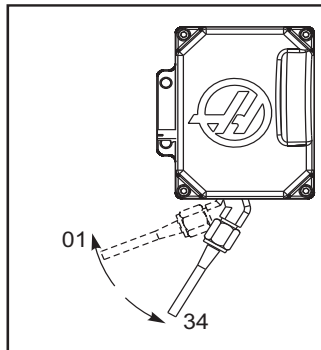

Programmable coolant (P-Cool) allows you to direct coolant to the tool at one of 34 positions. Generally, when you program P-Cool positions, you find the correct spigot position for each tool first. You can then specify that position in various ways.

### P-Cool Command Summary

- **M08 / M09** - Coolant On / Off (refer to page 324)
- **M34 / M35** - Coolant Increment / Decrement (refer to page 327)
- **[CLNT UP] / [CLNT DOWN]** - Move the P-Cool spigot up and down

### 5.5.1 P-Cool Positioning

Follow this procedure to determine the correct coolant position for each tool.



#### CAUTION:

*Do not move the P-Cool spigot by hand; this will damage the motor.  
Use only control commands.*

1. If you have a ball valve control to switch between coolant lock lines or P-Cool, make sure that the valve is set to the P-Cool position.
2. Press **[OFFSET]** until the **TOOL OFFSET** table appears on the display.
3. Command the first tool into the spindle. When the OFFSET table is active, you can press **[ATC FWD]** or **[ATC REV]** to change tools, or you can command **M06 TXX** in **MDI** mode, where **XX** is the desired tool number.
4. Press **[COOLANT]** to start the coolant flow.
5. Press **[CLNT UP]** or **[CLNT DOWN]** until the spigot position puts coolant where you want it to go.



6. Press [**COOLANT**] to stop the coolant flow.
7. Record the value next to CLNT POS at the bottom of the TOOL OFFSET table. There are several ways you can now use this position information.

**F5.8:** The Coolant Position Display

<< TOOL INFO	
TOOL 1	COOLANT
OFFSET	POSITION
10	0
11	0
12	0
13	0
14	0
15	0
16	0
17	0
18	0

CLNT POS 3

## Coolant Position in the Offsets Table

1. Highlight the COOLANT POSITION column for the desired tool in the TOOL OFFSET table.
2. Type the coolant position number for the tool.
3. Press [**F1**] to enter the value into the COOLANT POSITION column.
4. Repeat these steps for each tool.

The P-Cool spigot adjusts to the position in the COOLANT POSITION column when the program calls the tool and turns on coolant (M08).

## Coolant Position System Variables

If your machine has Macros enabled, you can specify coolant positions for tools 1 through 200 with system variables 3401 through 3600. For example, #3401=15 sets the coolant position for Tool 1 to position 15.

## Coolant Position in Program Blocks

You can also adjust the P-Cool spigot position in a program block with an M34 or M35 command. Each such command moves the spigot one position up (M35) or down (M34).

## 5.6 Servo Auto Door

This option adds a rack-and-pinion assembly to the machine doors, which allows them to open automatically. There are (3) ways to activate the Servo Auto Door:

1. Press the **[SERVO AUTO DOOR OVERRIDE]** button on the side of the control pendant to toggle the door open or closed.

**F5.9:** **[SERVO AUTO DOOR OVERRIDE]** Button [1]

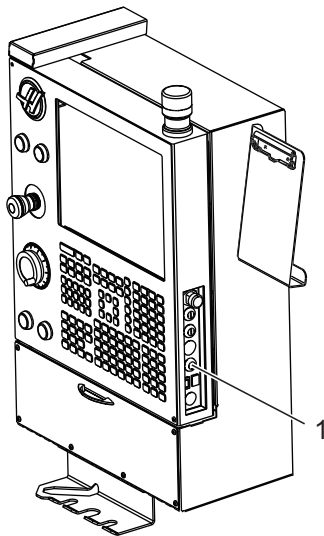

2. Use M-codes within a program that associate with the Servo Auto Door. For example, when Setting 131 is set to **ON**, the Servo Auto Door is paired with:
  - M00 (Stop program)
  - M01 (Optional Program Stop)
  - M30 (Program End and Reset)

When one of these M-codes is read, the door opens. Pressing **[CYCLE START]** automatically closes the door.

**NOTE:**

*Alarms do not result from a door fault if the door is operated with the **[SERVO AUTO DOOR OVERRIDE]** button. Alarms are generated for a door failure when operation is the result of the programming M-codes or the **[CYCLE START]** button operation.*

3. Command the Servo Auto Door in a program by inserting an M80 to open the door and an M81 to close it.  
The Servo Auto Door M-codes, (M80/M81) are for robot tending. Additional set-up is necessary to safely use the Auto door. Contact your Haas Factory Outlet before using this style of Servo Auto Door programming.

## 5.7 Through-Spindle Coolant (TSC)

This option delivers coolant directly to the tool's cutting edge, which allows for more aggressive speeds and feeds, and improved chip removal. Through-Spindle Coolant (TSC) is available in 300 psi (21 bar) and 1000 psi (69 bar) configurations. Both of these configurations are operated in the same way.

To turn on TSC, press **[AUX CLNT]** when TSC is off, or command an M88 in a program.

To turn off TSC, press **[AUX CLNT]** when TSC is on, or command an M89 in a program.

## 5.8 Other Options

The options listed in this section have documentation available on the Haas Automation website ([www.haascnc.com](http://www.haascnc.com)).

### 5.8.1 Wireless Intuitive Probing System (WIPS)

This option uses a spindle-mounted work probe and a table-mounted tool probe to set positions in the Haas control for improved accuracy and better repeatability.

### 5.8.2 Intuitive Programming System (IPS)

This option uses a series of easy-to-use menus and option fields to automatically generate G-code for a variety of part features.

## 5.9 More Information Online

For updated and supplemental information, including tips, tricks, maintenance procedures, and more, go to [www.HaasCNC.com](http://www.HaasCNC.com) and select the **Resource Center**.

# Chapter 6: G-codes, M-codes, Settings

## 6.1 Introduction

This chapter gives detailed descriptions of the G-codes, M-codes, and Settings that your machine uses. Each of these sections begins with a numerical list of codes and associated code names.

## 6.2 G-codes

Code	Description	Group
G00	Rapid Motion Positioning	01
G01	Linear Interpolation Motion	01
G02	Circular Interpolation Motion CW	01
G03	Circular Interpolation Motion CCW	01
G04	Dwell	00
G09	Exact Stop	00
G10	Set Offsets	00
G12	Circular Pocket Milling CW	00
G13	Circular Pocket Milling CCW	00
G17	XY Plane Selection	02
G18	XZ Plane Selection	02
G19	YZ Plane Selection	02
G20	Select Inches	06
G21	Select Metric	06
G28	Return To Machine Zero Point	00

<b>Code</b>	<b>Description</b>	<b>Group</b>
G29	Return From Reference Point	00
G31	Feed Until Skip	00
G35	Automatic Tool Diameter Measurement	00
G36	Automatic Work Offset Measurement	00
G37	Automatic Tool Offset Measurement	00
G40	Cutter Compensation Cancel	07
G41	2D Cutter Compensation Left	07
G42	2D Cutter Compensation Right	07
G43	Tool Length Compensation + (Add)	08
G44	Tool Length Compensation - (Subtract)	08
G47	Text Engraving	00
G49	G43/G44/G143 Cancel	08
G50	Cancel Scaling	11
G51	Scaling	11
G52	Set Work Coordinate System	00 or 12
G53	Non-Modal Machine Coordinate Selection	00
G54	Select Work Coordinate System #1	12
G55	Select Work Coordinate System #2	12
G56	Select Work Coordinate System #3	12
G57	Select Work Coordinate System #4	12
G58	Select Work Coordinate System #5	12
G59	Select Work Coordinate System #6	12
G60	Uni-Directional Positioning	00

Code	Description	Group
G61	Exact Stop Mode	15
G64	G61 Cancel	15
G65	Macro Subroutine Call Option	00
G68	Rotation	16
G69	Cancel G68 Rotation	16
G70	Bolt Hole Circle	00
G71	Bolt Hole Arc	00
G72	Bolt Holes Along an Angle	00
G73	High-Speed Peck Drilling Canned Cycle	09
G74	Reverse Tap Canned Cycle	09
G76	Fine Boring Canned Cycle	09
G77	Back Bore Canned Cycle	09
G80	Canned Cycle Cancel	09
G81	Drill Canned Cycle	09
G82	Spot Drill Canned Cycle	09
G83	Normal Peck Drilling Canned Cycle	09
G84	Tapping Canned Cycle	09
G85	Boring Canned Cycle	09
G86	Bore and Stop Canned Cycle	09
G87	Bore In and Manual Retract Canned Cycle	09
G88	Bore In, Dwell, Manual Retract Canned Cycle	09
G89	Bore In, Dwell, Bore Out Canned Cycle	09
G90	Absolute Position Command	03

<b>Code</b>	<b>Description</b>	<b>Group</b>
G91	Incremental Position Command	03
G92	Set Work Coordinate Systems Shift Value	00
G93	Inverse Time Feed Mode	05
G94	Feed Per Minute Mode	05
G95	Feed per Revolution	05
G98	Canned Cycle Initial Point Return	10
G99	Canned Cycle R Plane Return	10
G100	Cancel Mirror Image	00
G101	Enable Mirror Image	00
G102	Programmable Output to RS-232	00
G103	Limit Block Buffering	00
G107	Cylindrical Mapping	00
G110	#7 Coordinate System	12
G111	#8 Coordinate System	12
G112	#9 Coordinate System	12
G113	#10 Coordinate System	12
G114	#11 Coordinate System	12
G115	#12 Coordinate System	12
G116	#13 Coordinate System	12
G117	#14 Coordinate System	12
G118	#15 Coordinate System	12
G119	#16 Coordinate System	12
G120	#17 Coordinate System	12



<b>Code</b>	<b>Description</b>	<b>Group</b>
G121	#18 Coordinate System	12
G122	#19 Coordinate System	12
G123	#20 Coordinate System	12
G124	#21 Coordinate System	12
G125	#22 Coordinate System	12
G126	#23 Coordinate System	12
G127	#24 Coordinate System	12
G128	#25 Coordinate System	12
G129	#26 Coordinate System	12
G136	Automatic Work Offset Center Measurement	00
G141	3D+ Cutter Compensation	07
G143	5-Axis Tool Length Compensation +	08
G150	General Purpose Pocket Milling	00
G153	5-Axis High Speed Peck Drilling Canned Cycle	09
G154	Select Work Coordinates P1-P99	12
G155	5-Axis Reverse Tap Canned Cycle	09
G161	5-Axis Drill Canned Cycle	09
G162	5-Axis Spot Drill Canned Cycle	09
G163	5-Axis Normal Peck Drilling Canned Cycle	09
G164	5-Axis Tapping Canned Cycle	09
G165	5-Axis Boring Canned Cycle	09
G166	5-Axis Bore and Stop Canned Cycle	09
G169	5-Axis Bore and Dwell Canned Cycle	09

Code	Description	Group
G174	CCW Non-Vertical Rigid Tap	00
G184	CW Non-Vertical Rigid Tap	00
G187	Setting the Smoothness Level	00
G188	Get Program From PST	00

## Introduction to G-codes

G-codes tell the machine tool what type of action to perform, including:

- Rapid moves
- Move in a straight line or arc
- Set tool information
- Use letter addressing
- Define axis and beginning and ending positions
- Canned series of moves that bore a hole, cut a specific dimension, or a contour

Most CNC programs require you to know the G-codes to build a program to complete a part. For a description on how to use G-codes, refer to the basic programming section of the Programming chapter, starting on page **140**.



**NOTE:**

*The Haas Intuitive Programming System (IPS) is a programming mode that either hides G-code or completely bypasses the use of G-codes.*



**NOTE:**

*A program block can contain more than one G-code, as long as those G-codes are from different groups. You cannot place two G-codes from the same group in a program block. Also note that only one M-code per block is allowed.*

## Canned Cycles

Canned cycles are G-codes used to perform repetitive operations such as drilling, tapping, and boring. When a canned cycle is active, canned operations are performed with every X or Y movement. Canned cycles are canceled with G80. It is good practice to end each canned cycle with a G80 to avoid part, fixture, or machine damage. Additionally, make sure to include a G80 within the safe startup line with every tool change.

## Using Canned Cycles

You can program canned cycle X and Y positions in either absolute (G90) or incremental (G91).

Example:

```
G81 G99 Z-0.5 R0.1 F6.5 (This will drill one hole at the
present location) ;
G91 X-0.5625 L9 (This will drill 9 more holes .5625 equally
spaced in the negative direction) ;
```

If a canned cycle is defined without an X or Y and a loop count of 0 (L0), the cycle will not be performed at this location. The operation of the canned cycle will vary according to whether incremental (G91) or absolute (G90) positioning is active. Incremental motion in a canned cycle is often useful as a loop (L) count as it can be used to repeat the operation with an incremental X or Y move between cycles.

Example:

```
X1.25 Y-0.75 (center location of bolt hole pattern) ;
G81 G99 Z-0.5 R0.1 F6.5 L0 (L0 on the G81 line will not drill
a hole) ;
G70 I0.75 J10. L6 (6-hole bolt hole circle) ;
```

Once a canned cycle is commanded, that operation is done at every X-Y position listed in a block, until the canned cycle is canceled. Some of the canned cycle numerical values can be changed after the canned cycle is defined. The most important of these are the R plane value and the Z depth value. If these are listed in a block with XY commands, the XY move is done and all subsequent canned cycles are performed with the new R or Z value.

The X and Y positioning in a canned cycle is done with rapid moves.

G98 and G99 change the way the canned cycles operate. When G98 is active, the Z-Axis will return to the initial start plane at the completion of each hole in the canned cycle. This allows for positioning up and around areas of the part and/or clamps and fixtures.

When G99 is active, the Z-Axis returns to the R (rapid) plane after each hole in the canned cycle for clearance to the next XY location. Changes to the G98/G99 selection can also be made after the canned cycle is commanded, which will affect all later canned cycles.

A *P* address is an optional command for some canned cycles. This is a programmed pause at the bottom of the hole to help break chips, provide a smoother finish, and relieve any tool pressure to hold closer tolerance.



**NOTE:**

*A *P* address used for one canned cycle is used in others unless canceled (G00, G01, G80 or the [RESET] button).*

An *S* (spindle speed) command must be defined in, or before the G-code line of code.

Tapping in a canned cycle needs a feed rate calculated. The feed formula is:

Spindle speed divided by threads per inch of the tap = feedrate in inches per minute

The metric version of the feed formula is:

RPM times metric pitch = feedrate in mm per minute

Canned cycles also benefit from the use of Setting 57. If this setting is **ON**, the machine stops after the *X/Y* rapids before it moves the *Z* Axis. This is useful to avoid nicking the part when exiting the hole, especially if the *R* plane is close to the part surface.



**NOTE:**

*The *Z*, *R*, and *F* addresses are required data for all canned cycles.*

## Canceling a Canned Cycle

The *G80* code is used to cancel all canned cycles; note that a *G00* or *G01* code will also cancel a canned cycle. Once selected, a canned cycle is active until canceled with *G80*, *G00* or *G01*.

## Looping Canned Cycles

The following is an example of a program using a drilling canned cycle that is incrementally looped.



**NOTE:**

*The sequence of drilling used here is designed to save time and to follow the shortest path from hole to hole.*

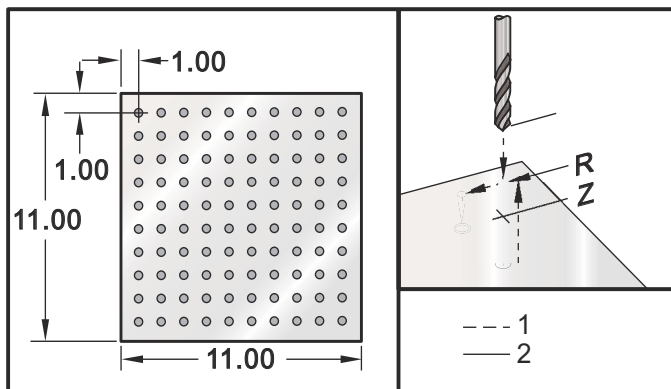
**F6.1:** G81 Drilling Canned Cycle: [R] R Plane, [Z] Z Plane, [1] Rapid, [2] Feed.**Program Example:**

```

%
O03400 (Drilling grid plate) ;
T1 M06 ;
G00 G90 G54 X1.0 Y-1.0 S2500 M03 ;
G43 H01 Z.1 M08 ;
G81 Z-1.5 F15. R.1 ;
G91 X1.0 L9 ;
G90 Y-2.0 (Or stay in G91 and repeat Y-1.0) ;
G91 X-1.0 L9 ;
G90 Y-3.0 ;
G91 X1.0 L9 ;
G90 Y-4.0 ;
G91 X-1.0 L9 ;
G90 Y-5.0 ;
G91 X1.0 L9 ;
G90 Y-6.0 ;
G91 X-1.0 L9 ;
G90 Y-7.0 ;
G91 X1.0 L9 ;
G90 Y-8.0 ;
G91 X-1.0 L9 ;
G90 Y-9.0 ;
G91 X1.0 L9 ;
G90 Y-10.0 ;
G91 X-1.0 L9 ;
G00 G90 G80 Z1.0 M09 ;
G28 G91 Y0Z0 ;
M30 ;
%
```

## X, Y Plane Obstacle Avoidance in a Canned Cycle:

To avoid an obstacle in the X, Y plane during a canned cycle place an L0 in a canned cycle line to make an X, Y move without executing the Z-Axis canned operation.

For example, having a six-inch square aluminum block, with a one-inch by one-inch deep flange on each side, the print calls for two holes centered on each side of the flange. The program example avoids each of the corners on the block.

Program Example:

```
%  
O4600 (X0,Y0 is at the top left corner, Z0 is at the top of  
the part) ;  
T1 M06 ;  
G00 G90 G54 X2.0 Y-.5 S3500 M03 ;  
G43 H01 Z-.9 M08 ;  
G81 Z-2.0 R-.9 F15. ;  
X4.0 ;  
X5.5 L0 (angular corner avoidance) ;  
Y-2.0 ;  
Y-4.0 ;  
Y-5.5 L0 ;  
X4.0 ;  
X2.0 ;  
X.5 L0 ;  
Y-4.0 ;  
Y-2.0v  
G00 G80 Z1.0 M09 ;  
G28 G91 Y0 Z0 ;  
M30 ;  
%
```

## Modifying Canned Cycles

In this section we will cover canned cycles that have to be customized in order to make the programming of difficult parts easier.

**Using G98 and G99 to clear clamps** – For example, A square part being held to the table with one-inch tall table clamps. A program needs to be written to clear the table clamps.

Program Example:

```
%  
O4500 ;  
T1 M06 ;  
G00 G90 G54 X1.0 Y-1.0 S3500 M03 ;
```

```

G43 H01 Z1.125 M08 ;
G81 G99 Z-1.500 R.05 F20. ;
X2.0 G98 (Will return to starting point after executing cycle)
;
X6.0 G99 (Will return to reference plane after executing
cycle) ;
X8.0 ;
X10.0 ;
X12.0 G98 ;
X16.0 G99 ;
X18.0 G98 ;
G00 G80 Z2.0 M09 ;
G28 G91 Y0 Z0 ;
M30 ;
%
```

## Drilling Canned Cycle Movements

**F6.2:** The illustrations in this section use these symbols to represent the various tool movements: [F] Feedrate, [1] Feed, [2] Rapid, [3] Begin or end stroke, [4] Manual Jog, [5] Shift (I, J / Q)

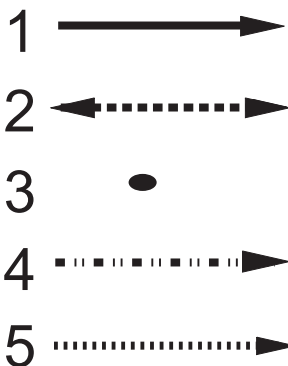

## G00 Rapid Motion Positioning (Group 01)

- X** - Optional X-Axis motion command
- Y** - Optional Y-Axis motion command
- Z** - Optional Z-Axis motion command
- A** - Optional A-Axis motion command
- B** - Optional B-Axis motion command
- C** - Optional C-axis motion command

G00 is used to move the machine axes at the maximum speed. It is primarily used to quickly position the machine to a given point before each feed (cutting) command. This G code is modal, so a block with G00 causes all following blocks to be rapid motion until another Group 01 code is specified.

A rapid move also cancels an active canned cycle, just like G80 does.



### NOTE:

*Generally, rapid motion will not be in a single straight line. Each axis specified is moved at the same speed, but all axes will not necessarily complete their motions at the same time. The machine will wait until all motions are complete before starting the next command.*

### F6.3: G00 Multi-linear Rapid Motion

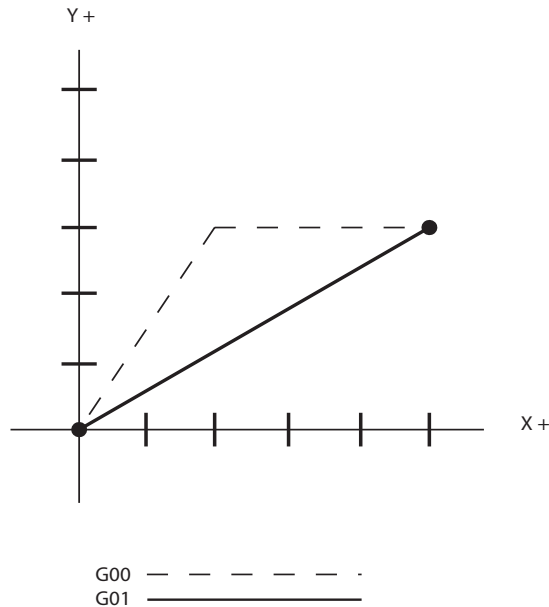



Setting 57 (Exact Stop Canned X-Y) can change how closely the machine waits for a precise stop before and after a rapid move.

## G01 Linear Interpolation Motion (Group 01)

**F** - Feedrate  
**X** - Optional X-Axis motion command  
**Y** - Optional Y-Axis motion command  
**Z** - Optional Z-Axis motion command  
**A** - Optional A-Axis motion command  
**B** - Optional B-Axis motion command  
**C** - Optional C-axis motion command  
**,R** - Radius of the arc  
**,C** - Chamfer distance

G01 moves the axes at a commanded feed rate. It is primarily used to cut the workpiece. A G01 feed can be a single axis move or a combination of the axes. The rate of axes movement is controlled by feedrate (F) value. This F value can be in units (inch or metric) per minute (G94) or per spindle revolution (G95), or time to complete the motion (G93). The feedrate value (F) can be on the current program line, or a previous line. The control will always use the most recent F value until another F value is commanded. If in G93, an F value is used on each line. See G93.

G01 is a modal command, which means that it will stay in affect until canceled by a rapid command such as G00 or a circular motion command like G02 or G03.

Once a G01 is started all programmed axes move and reach the destination at the same time. If an axis is not capable of the programmed feedrate the control will not proceed with the G01 command and an alarm (max feedrate exceeded) will be generated.

## Corner Rounding and Chamfering Example

**F6.4:** Corner Rounding and Chamfering Example

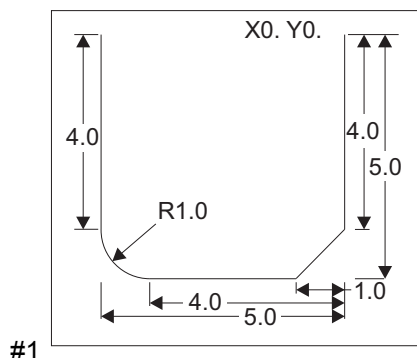

A chamfer block or a corner-rounding block can be automatically inserted between two linear interpolation blocks by specifying ,C (chamfering) or ,R (corner rounding). There must be a terminating linear interpolation block following the beginning block (a G04 pause may intervene).

These two linear interpolation blocks specify a corner of intersection. If the beginning block specifies a ,C, the value following the ,C is the distance from the intersection to where the chamfer begins, and also the distance from the intersection to where the chamfer ends. If the beginning block specifies an ,R, the value following the ,R is the radius of a circle tangent to the corner at two points: the beginning of the corner-rounding arc and the endpoint of that arc. There can be consecutive blocks with chamfering or corner rounding specified. There must be movement on the two axes specified by the selected plane, whether the active plane is XY (G17), XZ (G18) or YZ (G19).

## G02 CW / G03 CCW Circular Interpolation Motion (Group 01)

**F** - Feedrate

**I** - Optional distance along X Axis to center of circle

**J** - Optional distance along Y Axis to center of circle

**K** - Optional distance along Z Axis to center of circle

**R** - Optional radius of circle

**X** - Optional X-Axis motion command

**Y** - Optional Y-Axis motion command

**Z** - Optional Z-Axis motion command

**A** - Optional A-Axis motion command

Using **I**, **J** and **K** is the preferred method for programming a radius. **R** is suitable for general radii.

These G codes are used to specify circular motion. Two axes are necessary to complete circular motion and the correct plane, G17-G19, must be used. There are two methods of commanding a G02 or G03, the first is using the **I**, **J**, **K** addresses and the second is using the **R** address.

A chamfer or corner-rounding feature can be added to the program by specifying ,C (chamfering) or ,R (corner rounding), as described in the G01 definition.

## Using I, J, K addresses

I, J and K address are used to locate the arc center in relation to the start point. In other words, the I, J, K addresses are the distances from the starting point to the center of the circle. Only the I, J, or K specific to the selected plane are allowed (G17 uses IJ, G18 uses IK and G19 uses JK). The X, Y, and Z commands specify the end point of the arc. If the X, Y, and Z location for the selected plane is not specified, the endpoint of the arc is the same as the starting point for that axis.

To cut a full circle the I, J, K addresses must be used; using an R address will not work. To cut a full circle, do not specify an ending point (X, Y, and Z); program I, J, or K to define the center of the circle. For example:

```
G02 I3.0 J4.0 (Assumes G17; XY plane) ;
```

## Using the R address

The R-value defines the distance from the starting point to the center of the circle. Use a positive R-value for radii of 180° or less, and a negative R-value for radii more than 180°.

## Programming Examples

### F6.5: R Address Programming Example

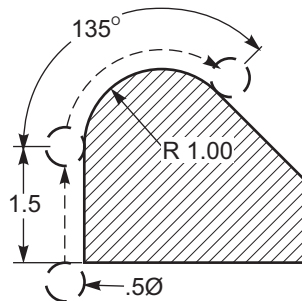

```
G90 G54 G00 X-0.25 Y-.25
G01 Y1.5 F12.
G02 X1.884 Y2.384 R1.25
```

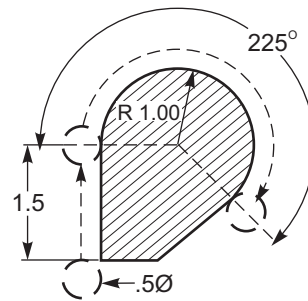

```
G90 G54 G00 X-0.25 Y-0.25
G01 Y1.5 F12.
G02 X1.884 Y0.616 R-1.25
```

## Thread Milling

Thread milling uses a standard G02 or G03 move to create the circular move in X-Y, then adds a Z move on the same block to create the thread pitch. This generates one turn of the thread; the multiple teeth of the cutter generate the rest. Typical line of code:

```
N100 G02 I-1.0 Z-.05 F5. (generates 1-inch radius for  
20-pitch thread) ;
```

Thread milling notes:

Internal holes smaller than 3/8 inch may not be possible or practical. Always climb cut the cutter.

Use a G03 to cut I.D. threads or a G02 to cut O.D. threads. An I.D. right hand thread will move up in the Z-Axis by the amount of one thread pitch. An O.D. right hand thread will move down in the Z-Axis by the amount of one thread pitch. PITCH = 1/Threads per inch (Example - 1.0 divided by 8 TPI = .125)

## Thread Milling Example:

This program will I.D. thread mill a 1.5 x 8 TPI hole using a .750 diameter x 1.0 thread hob.

1. To start, take the hole diameter (1.500). Subtract the cutter diameter .750 and then divide by 2.  $(1.500 - .75) / 2 = .375$   
The result (.375) is the distance the cutter starts from the I.D. of the part.
2. After the initial positioning, the next step of the program is to turn on cutter compensation and move to the I.D. of the circle.
3. The next step is to program a complete circle (G02 or G03) with a Z-Axis command of the amount of one full pitch of the thread (this is called Helical Interpolation).
4. The last step is to move away from the I.D. of the circle and turn off cutter compensation.

Cutter compensation cannot be turned off or on during an arc movement. A linear move must be made, either in the X or Y Axis to move the tool to and from the diameter to cut. This move will be the maximum compensation amount that can be adjusted.

**F6.6:** Thread Milling Example, 1.5 Diameter X 8 TPI: [1] Tool Path, [2] Turn on and off cutter compensation.

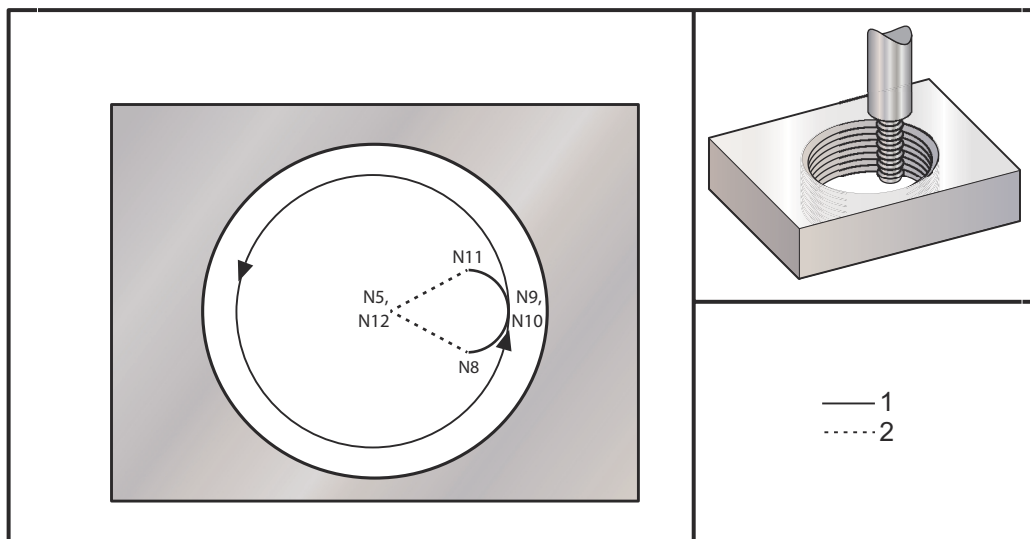

### Program Example



**NOTE:**

*Many of today's leading manufacturers of Thread Mills offer free online software to help the programmer create their G-code. This is very helpful when trying to write code for complex Tapered Thread Mill programs.*

```

%
O02300 (THREADMILL 1.5-8 UNC) ;
N1 T1 M06 (.5IN DIA THREADMILL) ;
N2 G00 G90 G40 G80 G54 ;
N3 M01 ;
N4 S3500 M03 ;
N5 X0 Y0 ;
N6 G43 Z0.1 H01 M08 ;
N7 G01 Z-0.5156 F50. ;
N8 G41 X0.25 Y-0.25 F10. D01 ;
N9 G03 X0.5 Y0 I0 J0.25 Z-0.5 ;
N10 I-0.5 J0 Z-0.375 F20. ;
N11 X0.25 Y0.25 I-0.25 J0 Z-0.3594 ;
N12 G40 G01 X0 Y0 ;
N13 G00 Z0.1 M09 ;
N14 G91 G28 Z0v
N15 M05 ;

```

N16 M30 ;

⌘

N5 = XY at the center of the hole

N7 = Thread depth, minus 1/8 pitch

N8 = Enable Cutter Compensation

N9 = Arcs into thread, ramps up by 1/8 pitch

N10 = Cuts full thread, Z moving up by the pitch value

N11 = Arcs out of thread, ramps up 1/8 pitch

N12 = Cancel Cutter Compensation



**NOTE:**

*Maximum cutter compensation adjustability is .175.*

## O.D. Thread Milling

**F6.7:** O.D. Thread Milling Example, 2.0 diameter post x 16 TPI: [1] Tool Path [2] Rapid Positioning, Turn on and off cutter compensation, [3] Start Position, [4] Arc with Z.

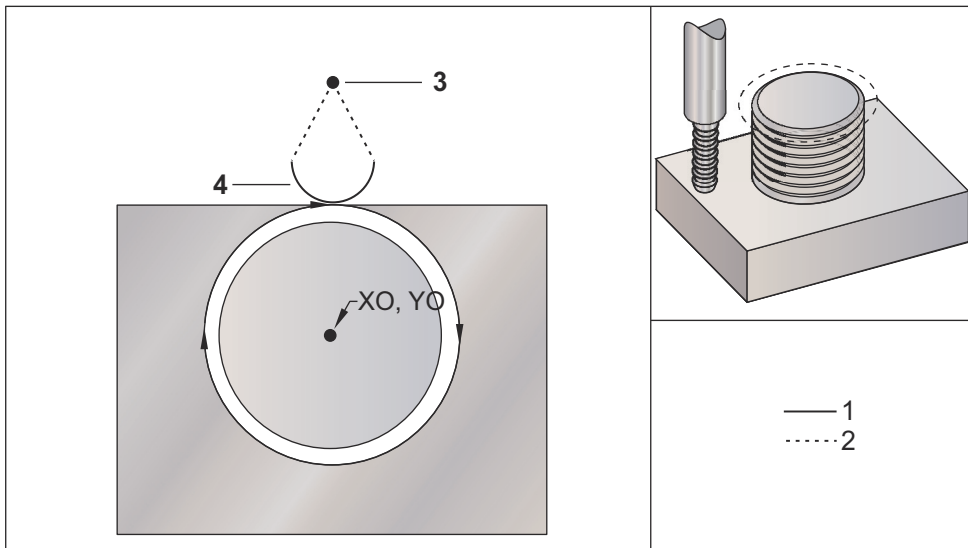

Program Example:

```

%
O02400 (Thread milling a 2.0 diameter post X 16 TPI) ;
T1 M06 (0.5 DIA. 2FLT. THREAD MILL) ;
G00 G90 G54 X-0.2 Y1.4 S1910 M03 (X0, Y0 is at the center of
the post) ;
G43 H01 Z0.1 M08 (Z0 at the top of the part-Post height is
1.125") ;
G00 Z-1. ;
G01 G41 D01 Y.962 F30. (Turn on Cutter Compensation) ;
G01 X0. F11.5 (Linear move to the post) ;
G02 J-0.962 Z-1.0625 (Circular move; negative Z move) ;
G01 X0.2 (Linear move away from the post) ;
G01 G40 Y1.4 F30. (Turn off Cutter Compensation) ;
G00 Z0.1 M09 ;
G28 G91 Y0. Z0. ;
M30 ;
%
```

**NOTE:**

*A cutter compensation move can consist of any X or Y move from any position just as long as the move is greater than the amount being compensated.*

## Single-Point Thread Milling Example

This program is for a 1.0" diameter hole with a cutter diameter of .500" and a thread pitch of .125 (8TPI). This program positions itself in Absolute G90 and then switches to G91 Incremental mode on line N7.

The use of an L<sub>xxx</sub> value on line N10 allows us to repeat the thread milling arc multiple times, with a Single-Point Thread Mill.

```

%
O02301 (THREADMILL 1.5-8 UNC) ;
(Single Point Thread Milling) ;
N1 T1 M06 (.5IN DIA THREADMILL) ;
N2 G00 G90 G40 G80 G54 ;
N3 M01 ;
N4 S5000 M03 ;
N5 X0 Y0 ;
N6 G43 Z0.1 H01 M08 ;
N7 G91 G01 Z-0.5156 F50. (Switches to G91) ;
N8 G41 X0.25 Y-0.25 F20. D01 ;
N9 G03 X0.25 Y0.25 I0 J0.25 Z0.0156 ;
N10 I-0.5 J0 Z0.125 L5 (Repeats 5 times) ;
```

```
N11 X-0.25 Y0.25 I-0.25 J0 Z0.0156 ;  
N12 G40 G01 X-0.25 Y-0.25 ;  
N13 G90 G00 Z0.1 M09 (Switches back to G90) ;  
N14 G91 G28 Z0 ;  
N15 M05 ;  
N16 M30 ;  
%
```

Specific line description:

N5 = XY at the center of the hole

N7 = Thread depth, minus 1/8 pitch. Switches to G91

N8 = Enable Cutter Compensation

N9 = Arcs into thread, ramps up by 1/8 pitch

N10 = Cuts full thread, Z moving up by the pitch value

N11 = Arcs out of thread, ramps up 1/8 pitch

N12 = Cancel Cutter Compensation

N13 = Switches back to G90 Absolute positioning

## Helical Motion

Helical (spiral) motion is possible with G02 or G03 by programming the linear axis that is not in the selected plane. This third axis will be moved along the specified axis in a linear manner, while the other two axes will be moved in the circular motion. The speed of each axis will be controlled so that the helical rate matches the programmed feedrate.

## G04 Dwell (Group 00)

**P** - The dwell time in seconds or milliseconds

G04 is used to cause a delay or dwell in the program. The block containing G04 will delay for the time specified by the P code. For example:

```
G04 P10.0. ;
```

This will delay the program for 10 seconds.



**NOTE:**

*Use of the decimal point G04 P10. is a dwell of 10 seconds; G04 P10 is a dwell of 10 milliseconds.*

## G09 Exact Stop (Group 00)

The G09 code is used to specify a controlled axes stop. It only affects the block in which it is commanded; it is non-modal, it does not affect the following blocks. Machine moves will decelerate to the programmed point before another command is processed.

## G10 Set Offsets (Group 00)

G10 allows the programmer to set offsets within the program. Using G10 replaces the manual entry of offsets (i.e. Tool length and diameter, and work coordinate offsets).

**L** – Selects offset category.

**L2** Work coordinate origin for G52 and G54-G59

**L10** Length offset amount (for H code)

**L1** or **L11** Tool wear offset amount (for H code)

**L12** Diameter offset amount (for D code)

**L13** Diameter wear offset amount (for D code)

**L20** Auxiliary work coordinate origin for G110-G129

**P** – Selects a specific offset.

**P1-P100** Used to reference D or H code offsets (L10-L13)

**P0** G52 references work coordinate (L2)

**P1-P6** G54-G59 references work coordinates (L2)

**P1-P20** G110-G129 references auxiliary coordinates (L20)

**P1-P99** G154

**P1-P99** reference auxiliary coordinate (L20)

**R** Offset value or increment for length and diameter.

**X** Optional X-Axis zero location.

**Y** Optional Y-Axis zero location.

**Z** Optional Z-Axis zero location.

**A** Optional A-Axis zero location.

Programming Examples:

```
G10 L2 P1 G91 X6.0 (Move coordinate G54 6.0 to the right) ;
G10 L20 P2 G90 X10. Y8. (Set work coordinate G111 to X10.0
,Y8.0) ;
G10 L10 G90 P5 R2.5 (Set offset for Tool #5 to 2.5) ;
G10 L12 G90 P5 R.375 (Set diameter for Tool #5 to .375") ;
G10 L20 P50 G90 X10. Y20. (Set work coordinate G154 P50 to
X10. Y20.) ;
```

## G12 Circular Pocket Milling CW / G13 Circular Pocket Milling CCW (Group 00)

These two G codes are used to mill circular shapes. They are different only in which direction of rotation is used. Both G codes use the default XY circular plane (G17) and imply the use of G42 (cutter compensation) for G12 and G41 for G13. These two G-codes are non-modal.

**\*D** - Tool radius or diameter selection

**F** - Feedrate

**I** - Radius of first circle (or finish if no K). I value must be greater than Tool Radius, but less than K value.

**K** - Radius of finished circle (if specified)

**L** - Loop count for repeating deeper cuts

**Q** - Radius increment, or stepover (must be used with K)

**Z** - Depth of cut or increment

\*In order to get the programmed circle diameter, the control uses the selected D code tool size. To program tool centerline select D0.



### NOTE:

*Specify D00 if no cutter compensation is desired. If no D is specified in the G12/G13 block, the last commanded D value will be used, even if it was previously canceled with a G40.*

The tool must be positioned at the center of the circle using X and Y. To remove all the material within the circle, use I and Q values less than the tool diameter and a K value equal to the circle radius. To cut a circle radius only, use an I value set to the radius and no K or Q value.

```
%
O00098 (SAMPLE G12 AND G13) ;
(OFFSET D01 SET TO APPROX. TOOL SIZE) ;
(TOOL MUST BE MORE THAN Q IN DIAM.) ;
T1M06 ;
G54G00G90X0Y0(Move to center of G54) ;
G43Z0.1H01 ;
S2000M03 ;
G12I1.5F10.Z-1.2D01(Finish pocket clockwise) ;
G00Z0.1 ;
G55X0Y0(Move to center of G55) ;
G12I0.3K1.5Q0.3F10.Z-1.2D01(Rough and finish clockwise) ;
G00Z0.1 ;
G56X0Y0(Move to center of G56) ;
G13I1.5F10.Z-1.2D01(Finish pocket counterclockwise) ;
G00Z0.1 ;
```

```

G57X0Y0 (Move to center of G57) ;
G13I0.3K1.5Q0.3F10.Z-1.2D01 (Rough and finish
counterclockwise) ;
G00Z0.1 ;
G28 ;
M30 ;

```

**F6.8:** Circular Pocket Milling, G12 Clockwise shown: [1] I only, [2] I, K and Q only.

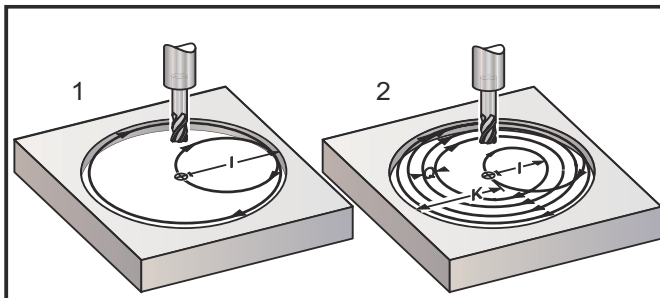

These G codes assume the use of cutter compensation, so a G41 or G42 is not required in the program line. However, a D offset number, for cutter radius or diameter, is required to adjust the circle diameter.

The following programming examples show the G12 and G13 format, as well as the different ways these programs can be written.

Single Pass: Use I only.

Applications: One-pass counter boring; rough and finish pocketing of smaller holes, ID cutting of O-ring grooves.

Multiple Pass: Use I, K, and Q.

Applications: Multiple-pass counter boring; rough and finish pocketing of large holes with cutter overlap.

Multiple Z-Depth Pass: Using I only, or I, K, and Q (G91 and L may also be used).

Applications: Deep rough and finish pocketing.

The previous figures show the tool path during the pocket milling G-codes.

Example G13 multiple-pass using I, K, Q, L, and G91:

This program uses G91 and an L count of 4, so this cycle will execute a total of four times. The Z depth increment is 0.500. This is multiplied by the L count, making the total depth of this hole 2.000.

The G91 and L count can also be used in a G13 I only line.

**NOTE:**

*If geometry column of control Offsets display has a value inserted, G12/G13 will read the data, whether a D0 is present or not. To cancel cutter compensation insert a D00 in the program line, this will bypass the value in the Offsets geometry column.*

**Program Example Description**

```
%  
O4000(0.500 entered in the Radius/Diameter offset column) ;  
T1 M06(Tool #1 is a 0.500" diameter endmill) ;  
G00 G90 G54 X0 Y0 S4000 M03 ;  
G43 H01 Z.1 M08 ;  
G01 Z0 F30. ;  
G13 G91 Z-.5 I.400 K2.0 Q.400 L4 D01 F20. ;  
G00 G90 Z1.0 M09 ;  
G28 G91 Y0 Z0 ;  
M30 ;  
%
```

**G17 XY / G18 XZ / G19 YZ Plane Selection (Group 02)**

The face of the workpiece to have a circular milling operation (G02, G03, G12, G13) done to it must have two of the three main axes (X, Y and Z) selected. One of three G codes is used to select the plane, G17 for XY, G18 for XZ, and G19 for YZ. Each is modal and applies to all subsequent circular motions. The default plane selection is G17, which means that a circular motion in the XY plane can be programmed without selecting G17. Plane selection also applies to G12 and G13, circular pocket milling, (always in the XY plane).

If cutter radius compensation is selected (G41 or G42), only use the XY plane (G17) for circular motion.

G17 Defined - Circular motion with the operator looking down on the XY table from above. This defines the motion of the tool relative to the table.

G18 Defined - Circular motion is defined as the motion for the operator looking from the rear of the machine toward the front control panel.

G19 Defined - Circular motion is defined as the motion for the operator looking across the table from the side of the machine where the control panel is mounted.

**F6.9:** G17, G18, and G19 Circular Motion Diagrams: [1] Top view, [2] Front view, [3] Right view.

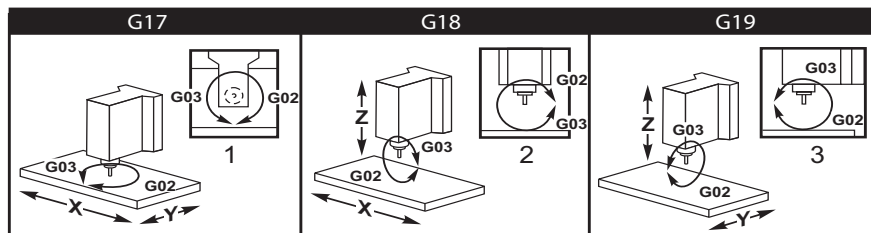

## G20 Select Inches / G21 Select Metric (Group 06)

The G codes G20 (inch) and G21 (mm) codes are used to ensure that the inch/metric selection is set correctly for the program. Selection between inch and metric programming should be done using Setting 9. A G20 in a program will cause the machine to alarm if Setting 9 is not set to inch.

## G28 Return to Machine Zero Point (Group 00)

The G28 code returns all axes (X, Y, Z, A and B) simultaneously to the machine zero position when no axis is specified on the G28 line.

Alternatively, when one or more axes locations are specified on the G28 line, G28 will move to the specified locations and then to machine zero. This is called the G29 reference point; it is saved automatically for optional use in G29.

G28 also cancels tool length offsets.

Setting 108 affects the way that rotary axes return when you command a G28. Refer to page 361 for more information.

### Program Examples

```
G28 G90 X0 Y0 Z0 (moves to X0 Y0 Z0) ;
(in the current work coordinate system then to machine zero) ;
G28 G90 X1. Y1. Z1. (moves to X1. Y1. Z1.) ;
(in the current work coordinate system then to machine zero) ;
G28 G91 X0 Y0 Z0 (moves directly to machine zero) ;
(because the initial incremental move is zero) ;
G28 G91 X-1. Y-1. Z-1 (moves incrementally -1.) ;
(in each axis then to machine zero) ;
```

## **G29 Return From Reference Point (Group 00)**

The G29 code is used to move the axes to a specific position. The axes selected in this block are moved to the G29 reference point saved in G28, and then moved to the location specified in the G29 command.

## **G31 Feed Until Skip (Group 00)**

(This G-code is optional and requires a probe)

This G-code is used to record a probed location to a macro variable.

**F** - Feedrate

**X** - X-Axis absolute motion command

**Y** - Y-Axis absolute motion command

**Z** - Z-Axis absolute motion command

**A** - A-Axis absolute motion command

**B** - B-Axis absolute motion command

**C** - C-axis absolute motion command (UMC)

This G-code moves the programmed axes while looking for a signal from the probe (skip signal). The specified move is started and continues until the position is reached or the probe receives a skip signal. If the probe receives a skip signal during the G31 move, the control will beep and the skip signal position will be recorded to macro variables. The program will then execute the next line of code. If the probe does not receive a skip signal during the G31 move, the control will not beep and the skip signal position will be recorded at the end of the programmed move. The program will continue.

Macro variables #5061 through #5066 are designated to store skip signal positions for each axis. For more information about these skip signal variables see the macro section of this manual.

Notes:

This code is non-modal and only applies to the block of code in which G31 is specified.

Do not use Cutter Compensation (G41, G42) with a G31.

The G31 line must have a Feed command. To avoid damaging the probe, use a feed rate below F100. (inch) or F2500. (metric).

Turn on the probe before using G31.

If your mill has the standard Renishaw probing system, use the following commands to turn on the probe.

Use the following code to turn on the spindle probe.

```
M59 P1134 ;
```

Use the following code to turn on the tool-setting probe.

```
M59 P1133 ;
G04 P1.0 ;
M59 P1134 ;
```

Use the following code to turn off either probe.

```
M69 P1134 ;
```

Also see M75, M78 and M79 ;

Sample program:

This sample program measures the top surface of a part with the spindle probe traveling in the Z negative direction. To use this program, the G54 part location must be set at, or close to the surface to be measured.

```
O00031 (G31 PROGRAM) ;
T30 M06 ;
G00 G90 G54 X0. Y0. ;
M59 P1134 ;
G43 H30 Z1. ;
G31 Z-0.25 F50. ;
Z1. ;
M69 P1134 ;
G00 G53 Z0. ;
M30 ;
```

## G35 Automatic Tool Diameter Measurement (Group 00)

(This G-code is optional and requires a probe)

This G-code is used to set a tool diameter offset.

**F** - Feedrate

**D** - Tool diameter offset number

**X** - Optional X-Axis command

**Y** - Optional Y-Axis command

Automatic Tool Diameter Offset Measurement function (G35) is used to set the tool diameter (or radius) using two touches of the probe; one on each side of the tool. The first point is set with a G31 block using an M75, and the second point is set with the G35 block. The distance between these two points is set into the selected (non-zero) D<sub>nnn</sub> offset.

Setting 63 Tool Probe Width is used to reduce the measurement of the tool by the width of the tool probe. See the settings section of this manual for more information about Setting 63.

This G-code moves the axes to the programmed position. The specified move is started and continues until the position is reached or the probe sends a signal (skip signal).

### NOTES:

This code is non-modal and only applies to the block of code in which G35 is specified.

Do not use Cutter Compensation (G41, G42) with a G35.

To avoid damaging the probe, use a feed rate below F100. (inch) or F2500. (metric).

Turn on the tool-setting probe before using G35.

If your mill has the standard Renishaw probing system, use the following commands to turn on the tool-setting probe.

```
M59 P1133 ;
G04 P1.0 ;
M59 P1134 ;
```

Use the following commands to turn off the tool-setting probe.

```
M69 P1134 ;
```

Turn on the spindle in reverse (M04), for a right handed cutter.

Also see M75, M78, and M79.

Also see G31.

Sample program:

This sample program measures the diameter of a tool and records the measured value to the tool offset page. To use this program, the G59 Work Offset location must be set to the tool-setting probe location.

```
O00035 (G35 PROGRAM) ;
T1 M06 ;
G00 G90 G59 X0. Y-1. ;
M59 P1133 ;
G04 P1. ;
M59 P1134 ;
G43 H01 Z1. ;
M04 S200 ;
G01 Z-0.25 F50. ;
G31 Y-0.25 F10. M75 ;
G01 Y-1. F25. ;
Z0.5 ;
Y1. ;
Z-0.25 ;
G35 Y0.25 D01 F10. ;
```



```
G01 Y1. F25. ;  
Z1. ;  
M69 P1134 ;  
G00 G53 Z0. ;  
M30 ;
```

## G36 Automatic Work Offset Measurement (Group 00)

(This G-code is optional and requires a probe)

This G-code is used to set work offsets with a probe.

**F** - Feedrate

**I** - Optional offset distance along X-Axis

**J** - Optional offset distance along Y-Axis

**K** - Optional offset distance along Z-Axis

**X** - Optional X-Axis motion command

**Y** - Optional Y-Axis motion command

**Z** - Optional Z-Axis motion command

Automatic Work Offset Measurement (G36) is used to command a probe to set work coordinate offsets. A G36 will feed the axes of the machine in an effort to probe the work piece with a spindle mounted probe. The axis (axes) will move until a signal from the probe is received or the end of the programmed move is reached. Tool compensation (G41, G42, G43, or G44) must not be active when this function is performed. The point where the skip signal is received becomes the zero position for the currently active work coordinate system of each axis programmed.

If an I, J, or K is specified, the appropriate axis work offset is shifted by the amount in the I, J, or K command. This allows the work offset to be shifted away from where the probe actually contacts the part.

### NOTES:

This code is non-modal and only applies to the block of code in which G36 is specified.

The points probed are offset by the values in Settings 59 through 62. See the settings section of this manual for more information.

Do not use Cutter Compensation (G41, G42) with a G36.

Do not use tool length Compensation (G43, G44) with G36

To avoid damaging the probe, use a feed rate below F100. (inch) or F2500. (metric).

Turn on the spindle probe before using G36.

If your mill has the standard Renishaw probing system, use the following commands to turn on the spindle probe.

```
M59 P1134 ;
```

Use the following commands to turn off the spindle probe.

```
M69 P1134 ;
```

Also see M78, and M79.

### **SAMPLE PROGRAM:**

```
O00036 (G36 PROGRAM) ;  
T30 M06 ;  
G00 G90 G58 X0. Y1. ;  
M59 P1134 ;  
Z-21.3 ;  
G01 G91 Y-0.5 F50. ;  
G36 Y-0.7 F10. ;  
G91 Y0.25 F50. ;  
G00 Z1. ;  
G90 ;  
M69 P1134 ;  
G00 G53 Z0. ;  
M30 ;
```

## **G37 Automatic Tool Offset Measurement (Group 00)**

(This G-code is optional and requires a probe)

This G-code is used to set tool length offsets.

**F** - Feedrate

**H** - Tool offset number

**Z** - Required Z-Axis offset

Automatic Tool Length Offset Measurement (G37) is used to command a probe to set tool length offsets. A G37 will feed the Z-Axis in an effort to probe a tool with a tool-setting probe. The Z-Axis will move until a signal from the probe is received or the travel limit is reached. A non-zero H code and either G43 or G44 must be active. When the signal from the probe is received (skip signal) the Z position is used to set the specified tool offset (Hnnn). The resulting tool offset is the distance between the current work coordinate zero point and the point where the probe is touched. If a non-zero Z value is on the G37 line of code the resulting tool offset will be shifted by the non-zero amount. Specify Z0 for no offset shift.

The work coordinate system (G54, G55, etc.) and the tool length offsets

(H01-H200) may be selected in this block or the previous block.

### **NOTES:**

This code is non-modal and only applies to the block of code in which G37 is specified.

A non-zero H code and either G43 or G44 must be active.

To avoid damaging the probe, use a feed rate below F100. (inch) or F2500. (metric).

Turn on the tool-setting probe before using G37.

If your mill has the standard Renishaw probing system, use the following commands to turn on the tool-setting probe.

```
M59 P1133 ;
G04 P1. ;
M59 P1134 ;
```

Use the following command to turn off the tool-setting probe.

```
M69 P1134 ;
```

Also see M78 and M79.

Sample program:

This sample program measures the length of a tool and records the measured value on the tool offset page. To use this program, the G59 work offset location must be set to the tool-setting probe location.

```
O00037 (G37 PROGRAM) ;
T1 M06 ;
M59 P1133 ;
G04 P1. ;
M59 P1134 ;
G00 G90 G59 X0. Y0. ;
G00 G43 H01 Z5. ;
G37 H01 Z0. F30. ;
G00 G53 Z0. ;
M69 P1134 ;
M30 ;
```

## G40 Cutter Comp Cancel (Group 07)

G40 will cancel G41 or G42 cutter compensation.

## **G41 2D Cutter Compensation Left / G42 2D Cutter Comp. Right (Group 07)**

G41 will select cutter compensation left; that is, the tool is moved to the left of the programmed path to compensate for the size of the tool. A D address must be programmed to select the correct tool radius or diameter offset. If the value in the selected offset is negative, cutter compensation will operate as though G42 (Cutter Comp Right.) was specified.

The right or left side of the programmed path is determined by looking at the tool as it moves away. If the tool needs to be on the left of the programmed path as it moves away, use G41. If it needs to be on the right of the programmed path as it moves away, use G42. For more information, refer to the Cutter Compensation section.

## **G43 Tool Length Compensation + (Add) / G44 Tool Length Comp - (Subtract) (Group 08)**

A G43 code selects tool length compensation in the positive direction; the tool length in the offsets page is added to the commanded axis position. A G44 code selects tool length compensation in the negative direction; the tool length in the offsets page is subtracted from the commanded axis position. A non-zero H address must be entered to select the correct entry from the offsets page.

## G47 Text Engraving (Group 00)

The Haas Control allows the operator to engrave a line of text, or sequential serial numbers, with a single G-code.



**NOTE:**

*Engraving along an arc is not supported.*

**E** - Plunge feed rate (units/min)  
**F** - Engraving feedrate (units/min)  
**I** - Angle of rotation (-360. to +360.); default is 0  
**J** - Height of text in in/mm (minimum = 0.001 inch); default is 1.0 inch  
**P** - 0 for literal string engraving  
   - 1 for sequential serial number engraving  
   - 32-126 for ASCII characters  
**R** - Return plane  
**X** - X start of engraving  
**Y** - Y start of engraving  
**Z** - Depth of cut

## Literal String Engraving (G47 P0)

This method is used to engrave text on a part. The text should be in the form of a comment on the same line as the G47 command. For example, G47 P0 (TEXT TO ENGRAVE), will engrave *TEXT TO ENGRAVE* on the part.



**NOTE:**

*Engraving along an arc is not supported.*

The characters available for engraving, using this method are:

A-Z, a-z 0-9, and ` ~ ! @ # \$ % ^ & \* - \_ = + [ ] { } \ | ; : ' " , . / < > ?

Not all of these characters can be entered from the control. When programming from the mill keypad, or engraving parenthesis (), refer to the following Engraving Special Characters section.

This example will create the figure shown.

```

O00036 (TEXT TO ENGRAVE) ;
T1 M06 ;
G00 G90 G98 G54 X0. Y0. ;
S7500 M03 ;

```

```
G43 H01 Z0.1 ;
G47 P0 (TEXT TO ENGRAVE) X2. Y2. I45. J0.5 R0.05 Z-0.005 F15.
E10.G00 G80 Z0.1 ;
M05 ;
G28 G91 Z0 ;
M30 ;
```

**F6.10:** Engraving Program Example

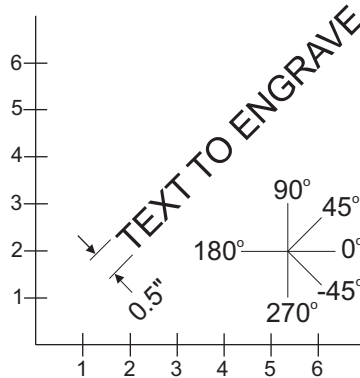

**In this example:**

```
G47 P0 (Select literal string engraving) ;
X2.0 Y2.0 (Sets the starting point for the text at the bottom
left corner of first letter) ;
I45. (Places the text at a positive 45° angle) ;
J.5 (Sets the text height to 0.5 units-in/mm) ;
R.05 (Cutter retracts to 0.05 units above part, after
engraving) ;
Z-.005 (Sets an engraving depth of -.005 units) ;
F15.0 (Sets an engraving, XY move, feedrate of 15 units per
minute) ;
E10.0 (Sets a plunge, -Z move, feedrate of 10 units per
minute) ;
```

## Engraving Special Characters

Engraving Special Characters involves using G47 with specific P values (G47 P32-126).

**P-** values to engrave specific characters

### T6.1: G47 P Values for Special Characters

32		space	59	;	semicolon
33	!	exclamation mark	60	<	less than
34	"	double quotation mark	61	=	equals
35	#	number sign	62	>	greater than
36	\$	dollar sign	63	?	question mark
37	%	percent sign	64	@	at sign
38	&	ampersand	65-90	A-Z	capitol letters
39	'	closed single quote	91	[	open square bracket
40	(	open parenthesis	92	\	backslash
41	)	close parenthesis	93	]	closed square bracket
42	*	asterisk	94	^	carrot
43	+	plus sign	95	_	underscore
44	,	comma	96	'	open single quote
45	-	minus sign	97-122	a-z	lowercase letters
46	.	period	123	{	open curly bracket
47	/	slash	124		vertical bar
48-57	0-9	numbers	125	}	closed curly bracket
58	:	colon	126	~	tilde

Example:

To engrave \$2.00, from the control, two lines of code are necessary. The first uses a P36 to engrave the dollar sign (\$), and the second uses P0 (2.00).



**NOTE:**

*The axes (XY start location) need to be shifted between the first and second line of code to make a space between the dollar sign and the 2.*

This is the only method for engraving parenthesis ().

## Setting Initial Serial Number to be Engraved

There are two ways to set the initial serial number to be engraved. The first requires replacing the # symbols within the parenthesis with the first number to be engraved. With this method, nothing is engraved when the G47 line is executed (it is only setting the initial serial number). Execute this once and then change the value within the parenthesis back to # symbols to engrave normally.

The following example will set the initial serial number to be engraved to 0001. Run this code once and then change (0001) to (#####).

```
G47 P1 (0001) ;
```

The second method for setting the initial serial number to be engraved is to change the Macro Variable where this value is stored (Macro Variable 599). The Macros option does not need to be enabled.

Press **[CURRENT COMMANDS]** then press **[PAGE UP]** or **[PAGE DOWN]** as needed to display the **MACRO VARIABLES** page. From that screen, enter 599 and press Down cursor.

Once 599 is highlighted on the screen, type in the initial serial number to engrave, **[1]** for example, then press **[ENTER]**.

The same serial number can be engraved multiple times on the same part with the use of a macro statement. The macros option is required. A macro statement as shown below could be inserted between two G47 engraving cycles to keep the serial number from incrementing to the next number. For more details, see the Macros section of this manual.

Macro Statement: #599=[#599-1]



## Sequential Serial Number Engraving (G47 P1)

This method is used to engrave numbers on a series of parts with the number being increased by one each time. The # symbol is used to set the number of digits in the serial number. For example, G47 P1 (####), limits the number to four digits while (##) would limit the serial number to two digits.



**NOTE:**

*Engraving along an arc is not supported.*

The following example will engrave a four digit serial number.

```
O00037 (SERIAL NUMBER ENGRAVING) ;
T1 M06 ;
G00 G90 G98 G54 X0. Y0. ;
S7500 M03 ;
G43 H01 Z0.1 ;
G47 P1 (####) X2. Y2. I0. J0.5 R0.05 Z-0.005 F15. E10. ;
G00 G80 Z0.1 ;
M05 ;
G28 G91 Z0 ;
M30 ;
```

## Engraving Around the Outside of a Rotary Part (G47, G107)

With the Haas Control it is possible to combine a G47 Engraving cycle with a G107 Cylindrical Mapping cycle to engrave text (or a serial number) along the Outside Diameter of a rotary part.

The following example will engrave a four digit serial number, along the O.D. of a Haas rotary part.

```
O00120 (G47 S/N with G107 Wrap) ;
T1 M06 ;
M03 S7500 ;
G54 G90 G00 G17 G40 G80 ;
X0.1 Y0. A0. (Start Point of Engrave) ;
G43 H01 Z0.1 ;
G107 A0. Y0. R1.25 (R is Radius of Part) ;
G47 P1 (####) X0.1 Y0. I90. J0.15 R0.05 Z-0.012 F30. E10. ;
G00 Z0.1 M09 ;
G91 G28 Z0. ;
G90 ;
G107(Turn OFF Cylindrical Mapping) ;
M05 ;
```

M30 ;

For more details on this cycle see the G107 section.

## G49 G43/G44/G143 Cancel (Group 08)

This G code cancels tool length compensation.



**NOTE:**

*An H0, G28, M30, and [RESET] will also cancel tool length compensation.*

## G50 Cancel Scaling (Group 11)

G50 cancels the optional scaling feature. Any axis scaled by a previous G51 command is no longer in effect.

## G51 Scaling (Group 11)

(This G-code is optional and requires Rotation and Scaling)

**X** - optional center of scaling for the X Axis

**Y** - optional center of scaling for the Y Axis

**Z** - optional center of scaling for the Z Axis

**P** - optional scaling factor for all axes; three-place decimal from 0.001 to 8383.000.

G51 [X...] [Y...] [Z...] [P...] ;

A scaling center is always used by the control in determining the scaled position. If any scaling center is not specified in the G51 command block, then the last commanded position is used as the scaling center.

When scaling (G51) is commanded, all X, Y, Z, I, J, K, or R values addressing machine motion are multiplied by a scaling factor and are offset relative to a scaling center.

G51 will affect all appropriate positioning values in the blocks following the G51 command. The X, Y and Z axes can be scaled using a P address, if a P address is not entered the Setting 71 scaling factor is used.

The following programs illustrate how scaling is performed when different scaling centers are used:

**F6.11:** G51 No Scaling Gothic Window: [1] Work coordinate origin.

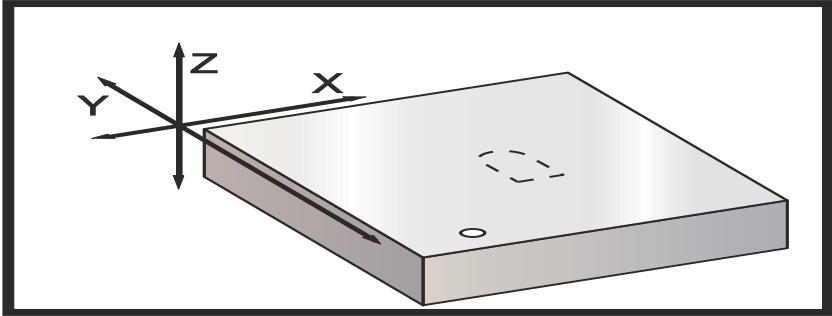

The first example illustrates how the control uses the current work coordinate location as a scaling center. Here, it is X0 Y0 Z0.

**F6.12:** G51 Scaling Current Work Coordinates: [1] Work coordinate origin, [2] Center of scaling.

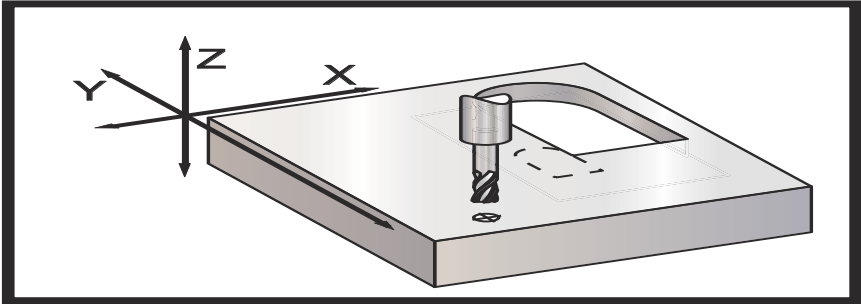

The next example specifies the center of the window as the scaling center.

**F6.13:** G51 Scaling Center of Window: [1] Work coordinate origin, [2] Center of scaling.

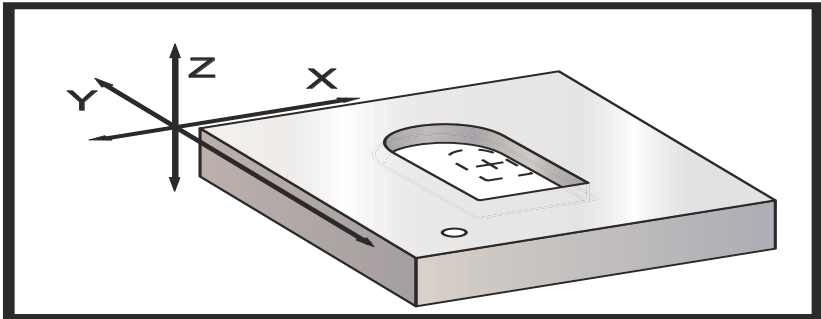

The last example illustrates how scaling can be placed at the edge of tool paths as if the part was being set against locating pins.

**F6.14:** G51 Scaling Edge of Tool Path: [1] Work coordinate origin, [2] Center of scaling.

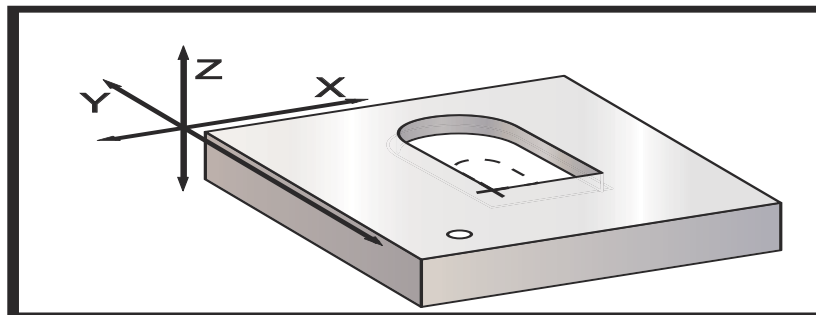

Programming notes:

Tool offsets and cutter compensation values are not affected by scaling.

Scaling does not affect canned cycle Z-Axis movements such as clearance planes and incremental values.

The final results of scaling are rounded to the lowest fractional value of the variable being scaled.

## G52 Set Work Coordinate System (Group 00 or 12)

The G52 command works differently depending on the value of Setting 33. Setting 33 selects the Fanuc, Haas, or Yasnac style of coordinates.

If **YASNAC** is selected, G52 is a group 12 G-code. G52 works the same as G54, G55, etc. All of the G52 values will not be set to zero (0) when powered on, reset is pressed, at the end of the program, or by an M30. When using a G92 (Set Work Coordinate Systems Shift Value), in Yasnac format, the X, Y, Z, A, and B values are subtracted from the current work position, and automatically entered into the G52 work offset.

If **FANUC** is selected, G52 is a group 00 G-code. This is a global work coordinate shift. The values entered into the G52 line of the work offset page are added to all work offsets. All of the G52 values in the work offset page will be set to zero (0) when powered on, reset is pressed, changing modes, at the end of the program, by an M30, G92 or a G52 X0 Y0 Z0 A0 B0. When using a G92 (Set Work Coordinate Systems Shift Value), in Fanuc format, the current position in the current work coordinate system is shifted by the values of G92 (X, Y, Z, A, and B). The values of the G92 work offset are the difference between the current work offset and the shifted amount commanded by G92.

If **HAAS** is selected, G52 is a group 00 G-code. This is a global work coordinate shift. The values entered into the G52 line of the work offset page are added to all work offsets. All of the G52 values will be set to zero (0) by a G92. When using a G92 (Set Work Coordinate Systems Shift Value), in Haas format, the current position in the current work coordinate system is shifted by the values of G92 (X, Y, Z, A, and B). The values of the G92 work offset are the difference between the current work offset and the shifted amount commanded by G92 (Set Work Coordinate Systems Shift Value).

## **G53 Non-Modal Machine Coordinate Selection (Group 00)**

This code temporarily cancels work coordinate offsets and uses the machine coordinate system. In the machine coordinate system, the zero point for each axis is the position where the machine goes when a Zero Return is performed. G53 will revert to this system for the block in which it is commanded.

## **G54-59 Select Work Coordinate System #1 - #6 (Group 12)**

These codes select one of more than six user coordinate systems. All future references to axes positions will be interpreted using the new (G54 G59) coordinate system. See also G154 for additional work offsets.

## **G60 Uni-Directional Positioning (Group 00)**

This G code is used to provide positioning only from the positive direction. It is provided only for compatibility with older systems. It is non-modal, so does not affect the blocks that follow it. See also Setting 35.

## **G61 Exact Stop Mode (Group 15)**

The G61 code is used to specify an exact stop. It is modal; therefore, it affects the blocks that follow it. The machine axes will come to an exact stop at the end of each commanded move.

## **G64 G61 Cancel (Group 15)**

The G64 code is used to cancel exact stop (G61).

## G65 Macro Subroutine Call Option (Group 00)

The G65 code is described in the Programming (Macros) section.

### G68 Rotation (Group 16)

(This G-code is optional and requires Rotation and Scaling.)

**G17, G18, G19** - optional plane of rotation, default is current

**A** - optional center of rotation for the first axis of the selected plane

**B** - optional center of rotation for the second axis of the selected plane

**R** - optional angle of rotation specified in degrees. Three-place decimal -360.000 to 360.000.

A G17, G18 or G19 must be used before G68 to establish the axis plane being rotated. For example:

```
G17 G68 Annn Bnnn Rnnn ;
```

A and B correspond to the axes of the current plane; for the G17 example A is the X-Axis and B is the Y-Axis.

A center of rotation is always used by the control to determine the positional values passed to the control after rotation. If any axis center of rotation is not specified, the current location is used as the center of rotation.

When rotation (G68) is commanded, all X, Y, Z, I, J, and K values are rotated through a specified angle R using a center of rotation.

G68 will affect all appropriate positional values in the blocks following the G68 command. Values in the line containing G68 are not rotated. Only the values in the plane of rotation are rotated, therefore, if G17 is the current plane of rotation, only X and Y values are affected.

Entering a positive number (angle) for the R address will rotate the feature counterclockwise.

If the angle of rotation (R) is not entered, then the angle of rotation is taken from Setting 72.

In G91 mode (incremental) with Setting 73 ON, the rotation angle is changed by the value in R. In other words, each G68 command will change the rotation angle by the value specified in R.

The rotational angle is set to zero at the beginning of the program, or it can be set to a specific angle using a G68 in G90 mode.

The following examples illustrate rotation using G68:

**F6.15:** G68 Start Gothic Window, No rotation: [1] Work coordinate origin.

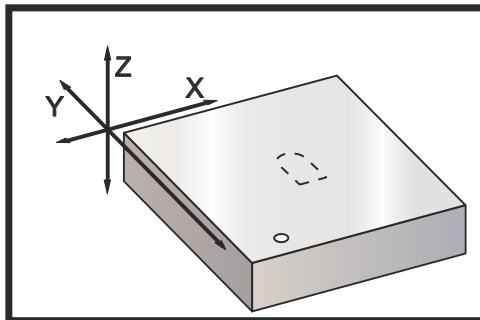

```
0001 (GOTHIC WINDOW) ;
F20, S500 ;
G00 X1. Y1. ;
G01 X2. ;
Y2. ;
G03 X1. R0.5
G01 Y1. ;
M99 ;
```

○ - 1

The first example illustrates how the control uses the current work coordinate location as a rotation center (X0 Y0 Z0).

**F6.16:** G68 Rotation Current Work Coordinate: [1] Work coordinate origin, [2] Center of rotation.

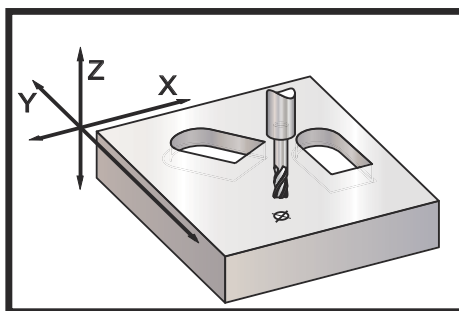

```
00002 ;
G59 ;
G00 G90 X0 Y0 Z0 ;
M98 P1 ;
G90 G00 X0 Y0 ; (Last Commanded Position)
G68 R60. ;
M98 P1 ;
G69 G90 G00 X0 Y0 ;
M30 ;
```

○ - 1

⊕ - 2

The next example specifies the center of the window as the rotation center.

**F6.17:** G68 Rotation Center of Window: [1] Work coordinate origin, [2] Center of rotation.

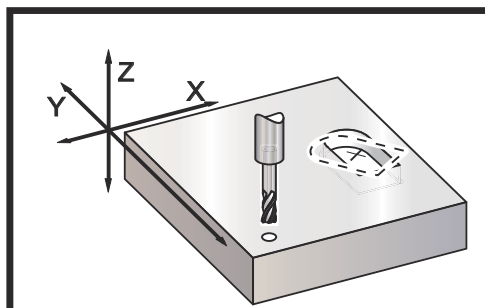

```
00003 ;
G59 ;
G00 G90 X0 Y0 Z0 ;
M98 P1 ;
G00 G90 X0 Y0 Z0 ;
G68 X1.5 Y1.5 R60. ;
M98 P1 ;
G69 G90 G00 X0 Y0 ;
M30 ;
```

○ - 1

⊕ - 2

This next example shows how the G91 mode can be used to rotate patterns about a center. This is often useful for making parts that are symmetric about a given point.

**F6.18:** G68 Rotate Patterns About Center: [1] Work coordinate origin, [2] Center of rotation.

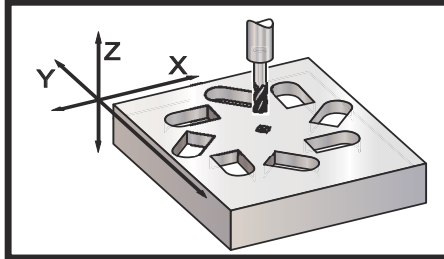

```
00004 ;  
G59 ;  
G00 G90 X0 Y0 Z0 ;  
M98 P10 L8 (SUBROUTINE 00010) ;  
M30 ;
```

```
00010 ;  
G91 G68 R45. ;  
G90 M98 P1 ;  
G90 G00 X0 Y0 ;  
M99 ;
```

○ - 1  
+ - 2

Do not change the plane of rotation while G68 is in effect.

Rotation with Scaling:

If scaling and rotation are used simultaneously, it is recommended that scaling be turned on prior to rotation, and that separate blocks be used. Use the following template when doing this.

```
G51 ... (SCALING) ;  
... ;  
G68 ... (ROTATION) ;  
... program ;  
G69 ... (ROTATION OFF) ;  
... ;  
G50 ... (SCALING OFF) ;
```

Rotation with Cutter Compensation:

Cutter compensation should be turned on after the rotation command is issued. Compensation should also be turned off prior to turning rotation off.

## G69 Cancel G68 Rotation (Group 16)

(This G-code is optional and requires Rotation and Scaling.)

G69 cancels any rotation specified previously.



## G70 Bolt Hole Circle (Group 00)

**I** - Radius (+CCW / -CW)

**J** - Starting angle (0 to 360.0 degrees CCW from horizontal; or 3 o'clock position)

**L** - Number of holes evenly spaced around the circle

This non-modal G code must be used with one of the canned cycles G73, G74, G76, G77, or G81-G89. A canned cycle must be active so that at each position, a drill or tap function is performed. See also G-code Canned Cycles section.

Program Example:

```
%
O01974 (G70 Example) ;
M06 T1 ;
M03 S1500 ;
G54 G00 G90 X0. Y0. ;
G43 H01 Z0.1 ;
G81 G98 Z-1. R0.1 F15. L0 (L0 on G81 does not drill a hole at
the center of the bolt hole circle) ;
G70 I5. J15. L12 (Drills 12 holes on a 10.0" diameter below
center starting at 15 degrees) ;
G80 G00 Z1. ;
M05 ;
M30 ;
%
```

## G71 Bolt Hole Arc (Group 00)

**I** - Radius (+CCW / -CW)

**J** - Starting angle (degrees CCW from horizontal)

**K** - Angular spacing of holes (+ or -)

**L** - Number of holes

This non-modal G code is similar to G70 except that it is not limited to a complete circle. G71 belongs to Group 00 and thus is non-modal. A canned cycle must be active so that at each position, a drill or tap function is performed.

## G72 Bolt Holes Along an Angle (Group 00)

- I** - Distance between holes (+CCW / -CW)  
**J** - Angle of line (degrees CCW from horizontal)  
**L** - Number of holes

This non-modal G code drills  $L$  number of holes in a straight line at the specified angle. It operates similarly to G70. For a G72 to work correctly, a canned cycle must be active so that at each position, a drill or tap function is performed.

- F6.19:** G70, G71, and G72 Bolt Holes: [**I**] Radius of bolt circle (G70, G71), or distance between holes (G72), [**J**] Starting angle from the 3 o'clock position, [**K**] Angular spacing between holes, [**L**] Number of holes.

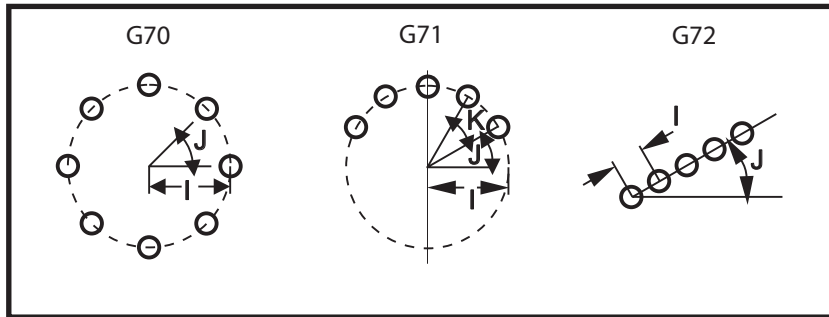

### Rules For Bolt Pattern Canned Cycles:

1. The tool must be placed at the center of the bolt pattern before the canned cycle execution.
2. The  $J$  code is the angular starting position and is always 0 to 360 degrees counterclockwise from the three o'clock position.
3. Placing an  $L0$  on the initial canned cycle line before an  $L$  used with a bolt pattern cycle will skip the initial XY location (that position is not drilled). Turning off Setting 28 (Can Cycle Act w/o X/Y) is another way to keep a hole from being drilled at the initial XY position. Refer to page 346 for more information on Setting 28.



#### NOTE:

*Using L0 is the preferred method.*

## G73 High-Speed Peck Drilling Canned Cycle (Group 09)

- F** - Feedrate
- I** - First peck depth
- J** - Amount to reduce pecking depth for pass
- K** - Minimum peck depth (The control calculates the number of pecks)
- L** - Number of loops (Number of holes to drill) if G91 (Incremental Mode) is used
- P** - Pause at the bottom of the hole (in seconds)
- Q** - Peck Depth (always incremental)
- R** - Position of the R plane (Distance above part surface)
- X** - X-Axis location of hole
- Y** - Y-Axis location of hole
- Z** - Position of the Z-Axis at the bottom of hole

**F6.20:** G73 Peck Drilling. Left: Using I, J, and K Addresses. Right: Using Only the Q Address. [#22] Setting 22.

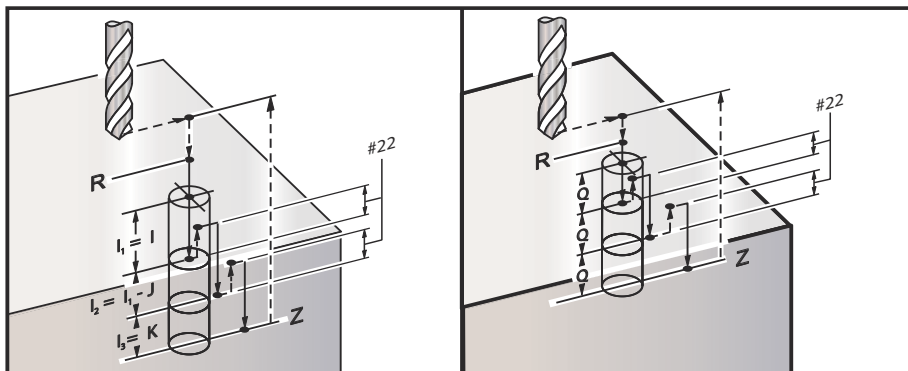

I, J, K, and Q are always positive numbers.

There are three methods to program a G73: using the I, J, K addresses, using the K and Q addresses, and using only a Q address.

If I, J, and K are specified, The first pass will cut in by the value I, each succeeding cut will be reduced by the value of J, and the minimum cutting depth is K. If P is specified, the tool will pause at the bottom of the hole for that amount of time.

If K and Q are both specified, a different operating mode is selected for this canned cycle. In this mode, the tool is returned to the R plane after the number of passes totals up to the K amount.

If only Q is specified, a different operating mode is selected for this canned cycle. In this mode, the tool is returned to the R plane after all pecks are completed, and all pecks will be equal to the Q value.

F6.21: G73 Peck Drilling Canned Cycles using the K and Q Addresses: [#22] Setting 22.

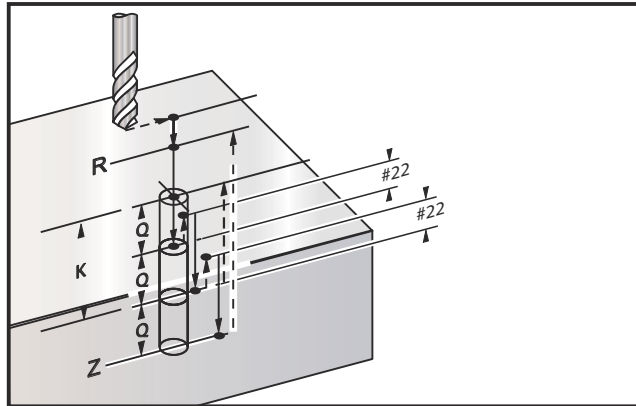

## G74 Reverse Tap Canned Cycle Group 09)

F - Feedrate. Use the formula described in the canned cycle introduction to calculate feedrate and spindle speed.

J - Retract Multiple (How fast to retract - see Setting 130)

L - Number of loops (How many holes to tap) if G91 (Incremental Mode) is used

R - Position of the R plane (position above the part) where tapping starts

X - X-Axis location of hole

Y - Y-Axis location of hole

Z - Position of the Z-Axis at the bottom of hole

F6.22: G74 Tapping Canned Cycle

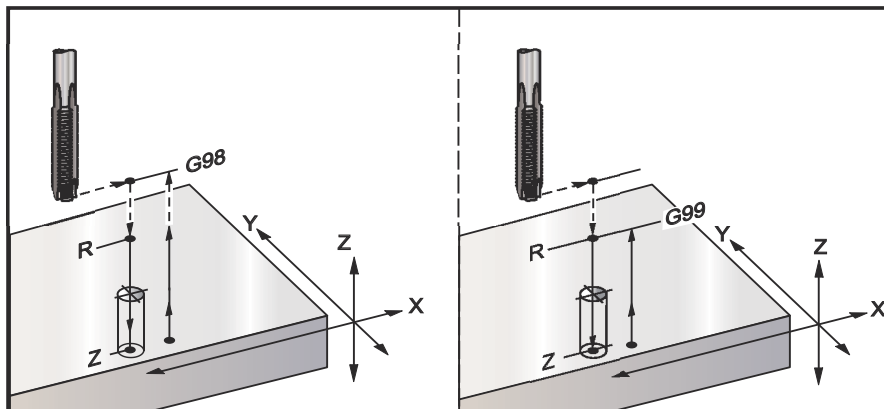

## G76 Fine Boring Canned Cycle (Group 09)

**F** - Feedrate

**I** - Shift value along the X-Axis before retracting, if  $Q$  is not specified

**J** - Shift value along the Y-Axis before retracting, if  $Q$  is not specified

**L** - Number of holes to bore if G91 (Incremental Mode) is used

**P** - The dwell time at the bottom of the hole

**Q** - The shift value, always incremental

**R** - Position of the R plane (position above the part)

**X** - X-Axis location of hole

**Y** - Y-Axis location of hole

**Z** - Position of the Z-Axis at the bottom of hole

### F6.23: G76 Fine Boring Canned Cycles

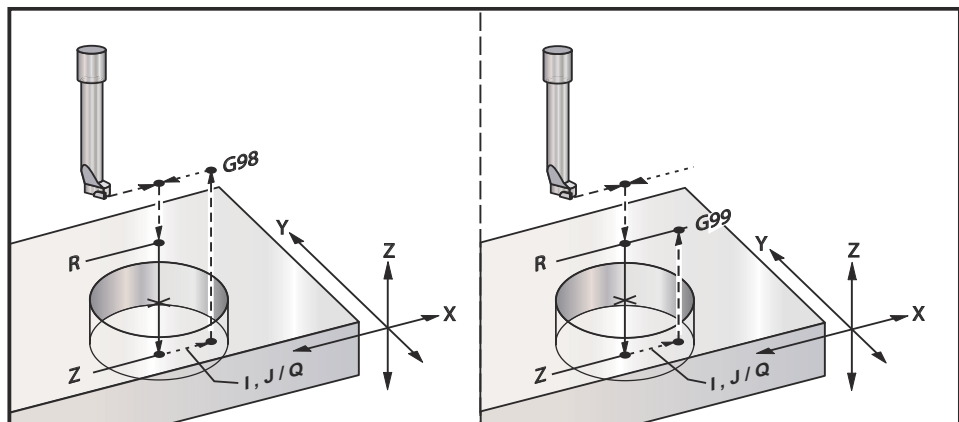

In addition to boring the hole, this cycle will shift the X and/or Y Axis prior to retracting in order to clear the tool while exiting the part. If  $Q$  is used Setting 27 determines the shift direction. If  $Q$  is not specified, the optional  $I$  and  $J$  values are used to determine the shift direction and distance.

## G77 Back Bore Canned Cycle (Group 09)

F - Feedrate

I - Shift value along the X-Axis before retracting, if Q is not specified

J - Shift value along the Y-Axis before retracting, if Q is not specified

L - Number of holes to bore if G91 (Incremental Mode) is used

Q - The shift value, always incremental

R - Position of the R plane (position above the part)

X - X-Axis location of hole

Y - Y-Axis location of hole

Z - Position of the Z-Axis at the bottom of hole

In addition to boring the hole, this cycle shifts the X and/or Y Axis prior to and after cutting in order to clear the tool while entering and exiting the part (see G76 for an example of a shift move). Setting 27 determines the shift direction. If Q is not specified, optional I and J values are used to determine shift direction and distance.

### F6.24: G77 Back Boring Canned Cycle

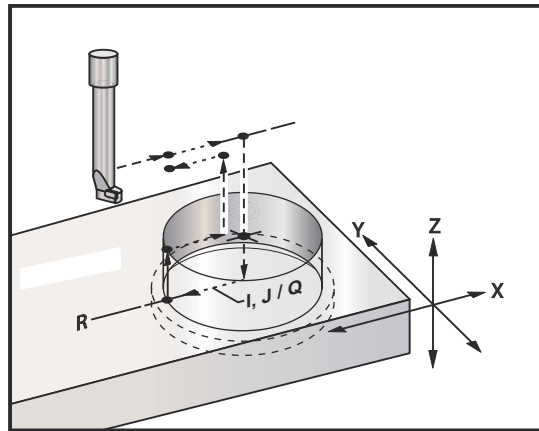

## G80 Canned Cycle Cancel (Group 09)

This G code deactivates all canned cycles until a new one is selected.



**NOTE:**

*Use of G00 or G01 will also cancel a canned cycle.*

## G81 Drill Canned Cycle (Group 09)

**F** - Feedrate

**L** - Number of holes to drill if G91 (Incremental Mode) is used

**R** - Position of the R plane (position above the part)

**X** - X-Axis motion command

**Y** - Y-Axis motion command

**Z** - Position of the Z-Axis at the bottom of hole

### F6.25: G81 Drill Canned Cycle

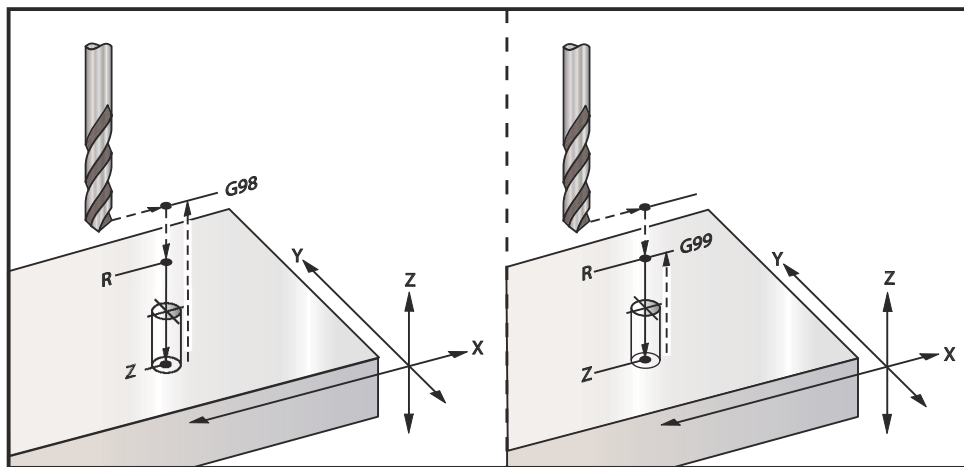

This is a program to drill through an aluminum plate:

```
T1 M06 ;
G00 G90 G54 X1.125 Y-1.875 S4500 M03 ;
G43 H01 Z0.1 ;
G81 G99 Z-0.35 R0.1 F27. ;
X2.0 ;
X3.0 Y-3.0 ;
X4.0 Y-5.625 ;
X5.250 Y-1.375 ;
G80 G00 Z1.0 ;
G28 ;
M30 ;
```

## G82 Spot Drill Canned Cycle (Group 09)

F - Feedrate

L - Number of holes if G91 (Incremental Mode) is used.

P - The dwell time at the bottom of the hole

R - Position of the R plane (position above the part)

X - X-Axis location of hole

Y - Y-Axis location of hole

Z - Position of bottom of hole



**NOTE:**

*G82 is similar to G81 except that there is the option to program a dwell (P).*

Program Example:

```

%
O1234 (Sample program) ;
T1 M06 (Tool #1 is a 0.5" x 90-degree spot drill) ;
G90 G54 G00 X.565 Y-1.875 S1275 M03 ;
G43 H01 Z0.1 M08 ;
G82 Z-0.175 P.3 R0.1 F10. ;
X1.115 Y-2.750 ;
X3.365 Y-2.875 ;
X4.188 Y-3.313 ;
X5.0 Y-4.0 ;
G80 G00 Z1.0 M09 ;

```

**F6.26:** G82 Spot Drilling Example

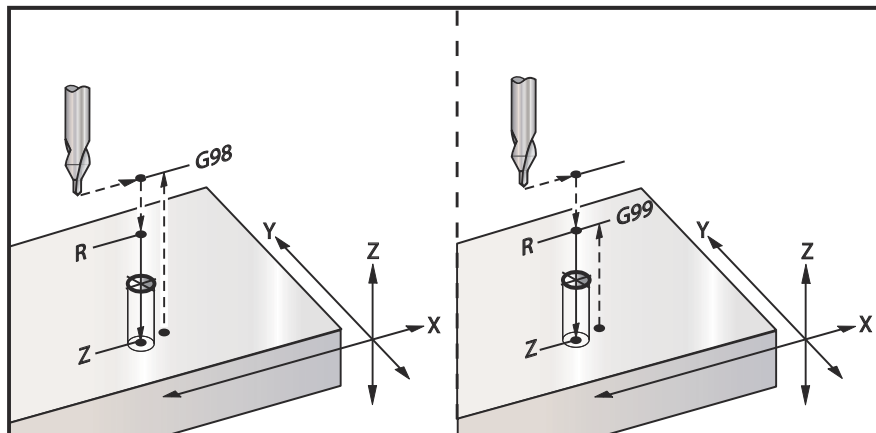



## G83 Normal Peck Drilling Canned Cycle (Group 09)

**F** - Feedrate

**I** - Size of first peck depth

**J** - Amount to reduce peck depth each pass

**K** - Minimum depth of peck

**L** - Number of holes if G91 (Incremental Mode) is used, also G81 through G89.

**P** - Pause at end of last peck, in seconds (Dwell)

**Q** - Peck depth, always incremental

**R** - Position of the R plane (position above the part)

**X** - X-Axis location of hole

**Y** - Y-Axis location of hole

**Z** - Position of the Z-Axis at the bottom of hole

If **I**, **J**, and **K** are specified, the first pass will cut in by the amount of **I**, each succeeding cut will be reduced by amount **J**, and the minimum cutting depth is **K**. Do not use a **Q** value when programming with **I**, **J**, and **K**.

If **P** is specified, the tool will pause at the bottom of the hole for that amount of time. The following example will peck several times and dwell for 1.5 seconds:

```
G83 Z-0.62 F15. R0.1 Q0.175 P1.5 ;
```

The same dwell time will apply to all subsequent blocks that do not specify a dwell time.

**F6.27:** G83 Peck Drilling with **I**, **J**, **K** and Normal Peck Drilling: [#22] Setting 22.

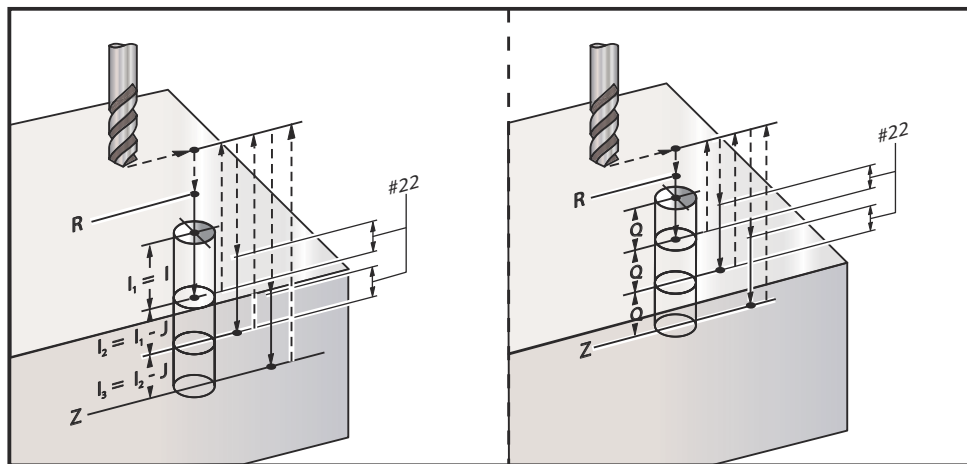

Setting 52 changes the way G83 works when it returns to the R plane. Usually the R plane is set well above the cut to ensure that the peck motion allows the chips to get out of the hole. This wastes time as the drill starts by drilling empty space. If Setting 52 is set to the distance required to clear chips, you can set the R plane much closer to the part. When the chip-clearing move to R occurs, Setting 52 determines the Z-Axis distance above R.

### F6.28: G83 peck Drilling Canned Cycle with Setting 52 [#52]

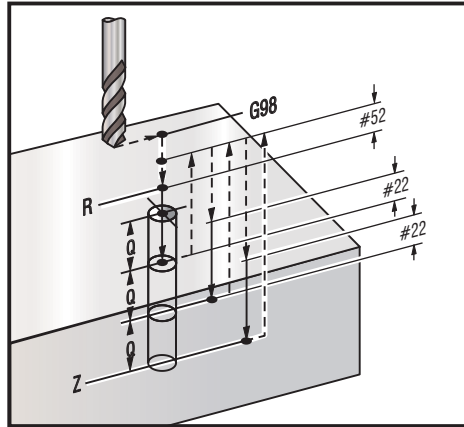

#### Program Example:

```
T2 M06 (Tool #2 is a 0.3125" stub drill) ;  
G90 G54 G00 X0.565 Y-1.875 S2500 M03 ;  
G43 H02 Z0.1 M08 ;  
G83 Z-0.720 Q0.175 R0.1 F15. ;  
X1.115 Y-2.750 ;  
X3.365 Y-2.875 ;  
X4.188 Y-3.313 ;  
X5.0 Y-4.0 ;  
G80 G00 Z1.0 M09 ;
```

## G84 Tapping Canned Cycle (Group 09)

**F** - Feedrate

**J** - Retract Multiple (Example: J2 will retract twice as fast as the cutting speed, also see Setting 130)

**L** - Number of holes if G91 (Incremental Mode) is used

**R** - Position of the R plane (Position above the part)

**X** - X-Axis location of hole

**Y** - Y-Axis location of hole

**Z** - Position of the Z Axis at the bottom of hole

**S** - Optional spindle speed



#### **NOTE:**

*You do not need to command a spindle start (M03 / M04) before G84. The canned cycle starts and stops the spindle as needed.*

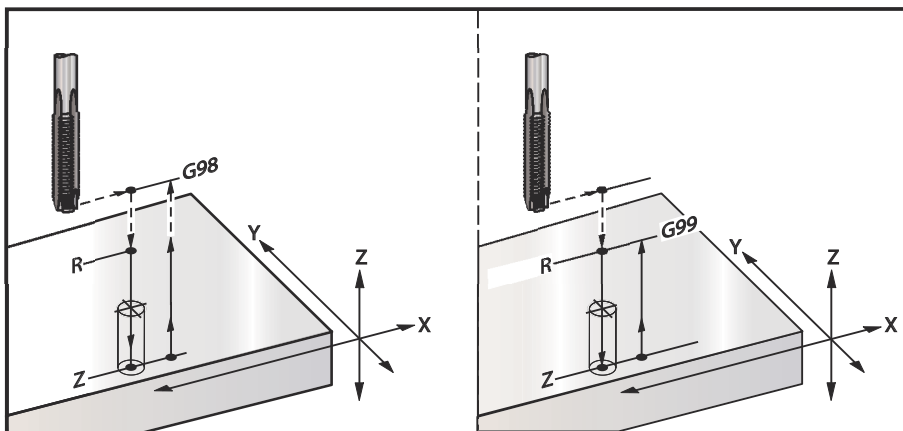
**F6.29:** G84 Tapping Canned Cycle**Program Example:**

```

T3 M06 (Tool #3 is a 3/8-16 tap) ;
G90 G54 G00 X0.565 Y-1.875;
G43 H03 Z0.2 M08 ;
G84 Z-0.600 R0.2 F56.25 S900 (900 rpm divided by 16 tpi = 56.25
ipm) ;
X1.115 Y-2.750 ;
X3.365 Y-2.875 ;
X4.188 Y-3.313 ;
X5.0 Y-4.0 ;
G80 G00 Z1.0 M09 ;
G28 G91 Y0 Z0 ;
M30 ;
%
```

## G85 Bore In, Bore Out Canned Cycle (Group 09)

F - Feedrate

L - Number of holes if G91 (Incremental Mode) is used

R - Position of the R plane (position above the part)

X - X-Axis location of holes

Y - Y-Axis location of holes

Z - Position of the Z Axis at the bottom of hole

### F6.30: G85 Boring Canned Cycle

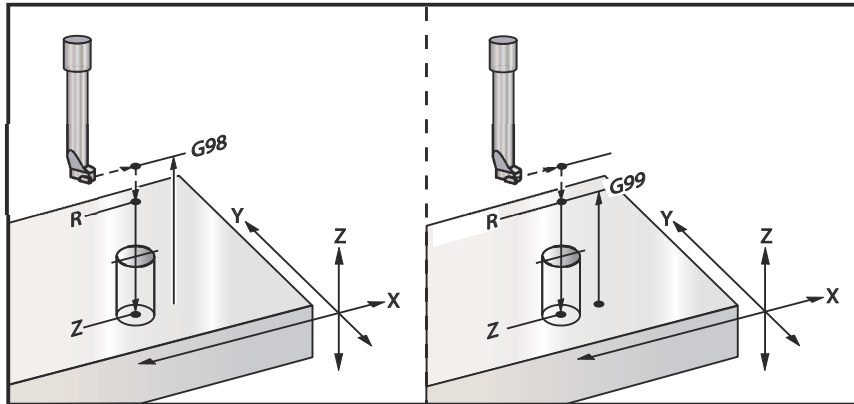

## G86 Bore and Stop Canned Cycle (Group 09)

F - Feedrate

L - Number of holes if G91 (Incremental Mode) is used

R - Position of the R plane (position above the part)

X - X-Axis location of hole

Y - Y-Axis location of hole

Z - Position of the Z Axis at the bottom of hole

This G code will stop the spindle once the tool reaches the bottom of the hole. The tool is retracted once the spindle has stopped.

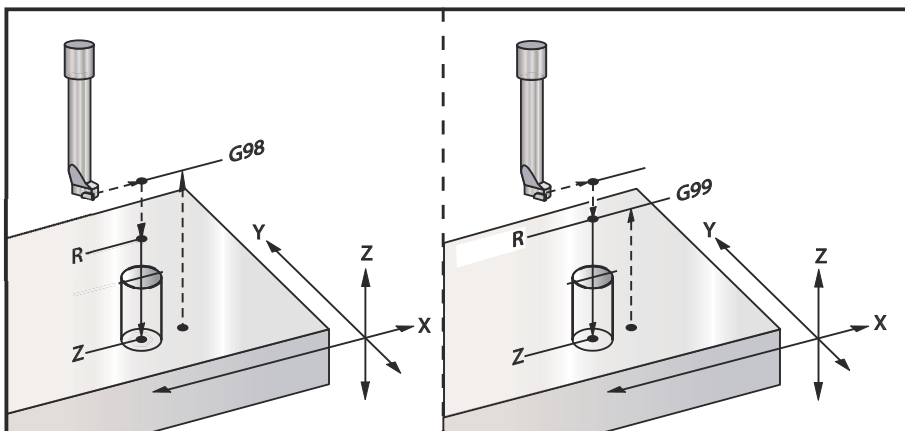
**F6.31:** G86 Bore and Stop Canned Cycles**G87 Bore In and Manual Retract Canned Cycle (Group 09)**

**F** - Feedrate

**L** - Number of holes if G91 (Incremental Mode) is used

**R** - Position of the R plane (position above the part)

**X** - X-Axis location of hole

**Y** - Y-Axis location of hole

**Z** - Position of the Z Axis at the bottom of hole

This G code will stop the spindle at the bottom of the hole. At this point the tool is manually jogged out of the hole. The program continues when **[CYCLE TART]** is pressed.

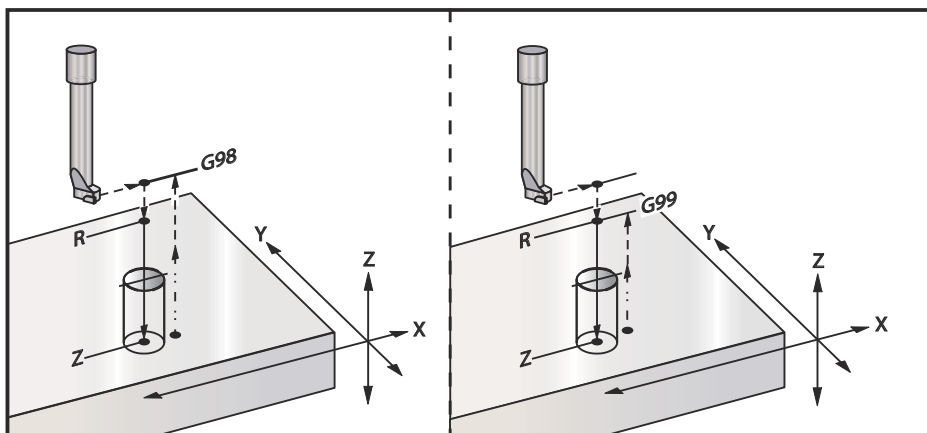
**F6.32:** G87 Bore and Stop and Manual Retract

## G88 Bore In, Dwell, Manual Retract Canned Cycle (Group 09)

F - Feedrate

L - Number of holes if G91 (Incremental Mode) is used

P - The dwell time at the bottom of the hole

R - Position of the R plane (position above the part)

X - X-Axis location of hole

Y - Y-Axis location of hole

Z - Position of the Z Axis at the bottom of hole

This G code stops the tool at the bottom of the hole, and dwells with the tool turning for the time designated with the P value. At this point the tool is manually jogged out of the hole. The program will continue when **[CYCLE START]** is pressed.

F6.33: G88 Bore and Dwell and Manual Retract

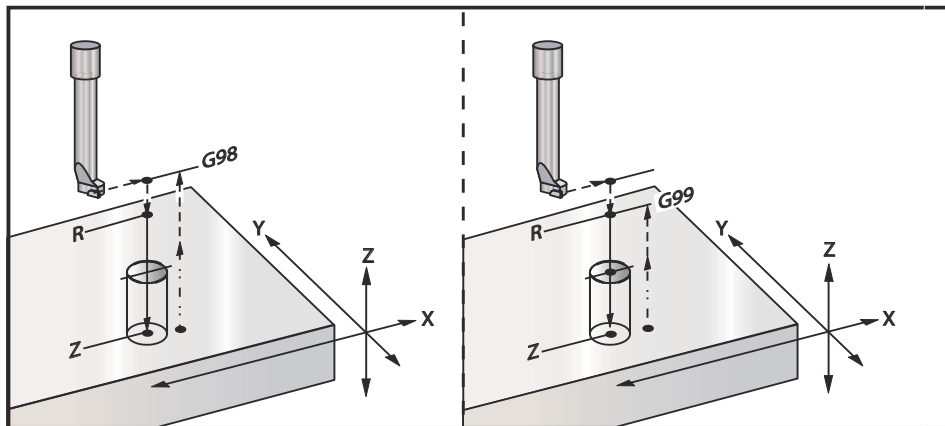

## G89 Bore In, Dwell, Bore Out Canned Cycle (Group 09)

- F** - Feedrate
- L** - Number of holes if G91 (Incremental Mode) is used
- P** - The dwell time at the bottom of the hole
- R** - Position of the R plane (position above the part)
- X** - X-Axis location of holes
- Y** - Y-Axis location of holes
- Z** - Position of the Z Axis at the bottom of hole

**F6.34:** G89 Bore and Dwell and Canned Cycle

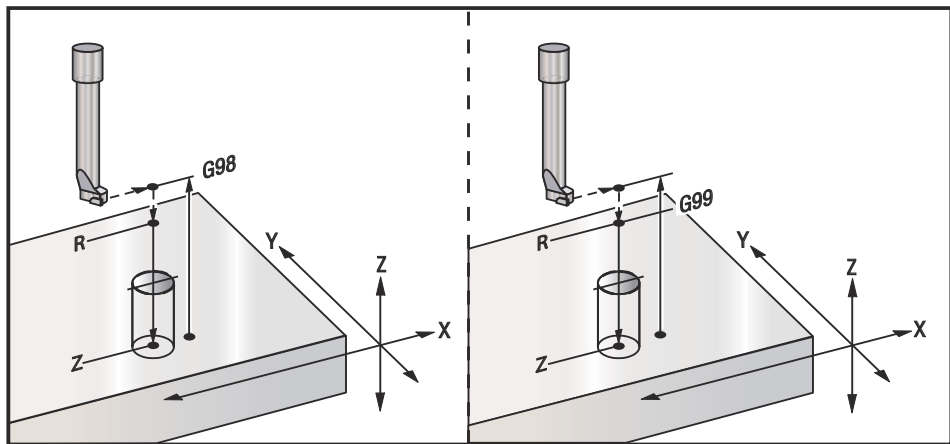

## G90 Absolute - G91 Incremental Position Commands (Group 03)

These G codes change the way the axis commands are interpreted. Axes commands following a G90 will move the axes to the machine coordinate. Axes commands following a G91 will move the axis that distance from the current point. G91 is not compatible with G143 (5-Axis Tool Length Compensation).

The Basic Programming section of this manual, beginning on page 143, includes a discussion of absolute versus incremental programming.

## G92 Set Work Coordinate Systems Shift Value (Group 00)

This G-code does not move any of the axes; it only changes the values stored as user work offsets. G92 works differently depending on Setting 33, which selects a FANUC, HAAS, or YASNAC coordinate system.

### FANUC or HAAS

If Setting 33 is set to **FANUC** or **HAAS**, a G92 command shifts all work coordinate systems (G54-G59, G110-G129) so that the commanded position becomes the current position in the active work system. G92 is non-modal.

A G92 command cancels any G52 in effect for the commanded axes. Example: G92 X1 .4 cancels the G52 for the X-Axis. The other axes are not affected.

The G92 shift value is displayed at the bottom of the Work Offsets page and may be cleared there if necessary. It is also cleared automatically after power-up, and any time **[ZERO RETURN]** and **[ALL]** or **[ZERO RETURN]** and **[SINGLE]** are used.

### G92 Clear Shift Value From Within a Program

G92 shifts may be canceled by programming another G92 shift to change the current work offset back to the original value.

### Example

```
%  
O00092 ;  
G00 G90 G54 X0. Y0. ;  
G92 X2. Y2. (Shifts current G54 work offset) ;  
G00 G90 G54 X0. Y0. ;  
G92 X-2. Y-2. (Shifts current G54 work offset back to  
original) ;  
G00 G90 G54 X0. Y0. ;  
M30 ;  
%
```

### YASNAC

If Setting 33 is set to **YASNAC**, a G92 command sets the G52 work coordinate system so that the commanded position becomes the current position in the active work system. The G52 work system then automatically becomes active until another work system is selected.



## G93 Inverse Time Feed Mode (Group 05)

**F** - Feed Rate (strokes per minute)

This G code specifies that all **F** (feedrate) values are interpreted as strokes per minute. In other words the time (in seconds) to complete the programmed motion using **G93** is, 60 (seconds) divided by the **F** value.

**G93** is generally used in 4 and 5-axis work when the program is generated using a CAM system. **G93** is a way of translating the linear (inches/min) feedrate into a value that takes rotary motion into account. When **G93** is used, the **F** value will tell you how many times per minute the stroke (tool move) can be repeated.

When **G93** is used, feedrate (**F**) is mandatory for all interpolated motion blocks. Therefore each non-rapid motion block must have its own feedrate (**F**) specification.



**NOTE:**

*Pressing [RESET] will set the machine to **G94** (Feed per Minute) mode. Settings 34 and 79 (4th & 5th axis diameter) are not necessary when using **G93**.*

## G94 Feed Per Minute Mode (Group 05)

This code deactivates **G93** (Inverse Time Feed Mode) and returns the control to Feed Per Minute mode.

## G95 Feed per Revolution (Group 05)

When **G95** is active, a spindle revolution will result in a travel distance specified by the Feed value. If Setting 9 is set to **INCH**, then the feed value **F** will be taken as inches/rev (set to **MM**, then the feed will be taken as mm/rev). Feed Override and Spindle Override will affect the behavior of the machine while **G95** is active. When a Spindle Override is selected, any change in the spindle speed will result in a corresponding change in feed in order to keep the chip load uniform. However, if a Feed Override is selected, then any change in the Feed Override will only affect the feed rate and not the spindle.

## G98 Canned Cycle Initial Point Return (Group 10)

Using G98, the Z-Axis returns to its initial starting point (the Z position in the block before the canned cycle was commanded) between each X and/or Y location. This allows for positioning up and around areas of the part and/or clamps and fixtures.

### F6.35: G98 Initial Point Return

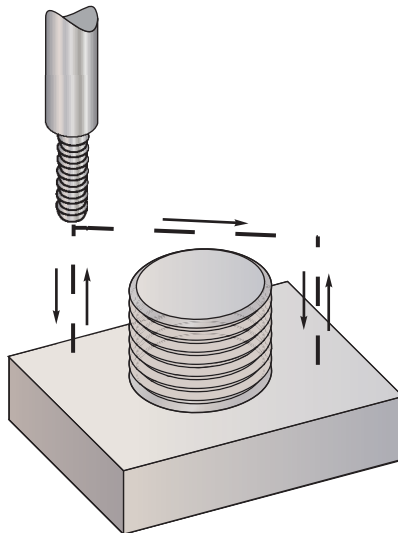

### Program Example

```

%
O4500 ;
T1 M06 ;
G00 G90 G54 X1.0 Y-1.0 S3500 M03 ;
G43 H01 Z1.125 M08 ;
G81 G99 Z-1.500 R.05 F20. ;
X2.0 G98 (Will return to starting point after executing cycle)
;
X6.0 G99 (Will return to reference plane after executing
cycle) ;
X8.0 ;
X10.0 ;
X12.0 G98 ;
X16.0 G99 ;
X18.0 G98 ;
G00 G80 Z2.0 M09 ;
G28 G91 Y0 Z0 ;
M30 ;
%
```

## G99 Canned Cycle R Plane Return (Group 10)

Using G99, the Z-Axis will stay at the R plane between each X and/or Y location. When obstructions are not in the path of the tool G99 saves machining time.

### F6.36: G99 R Plane Return

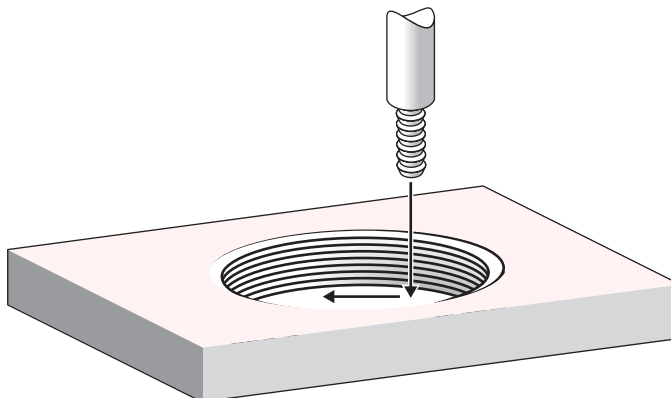

### Program Example

```

%
O4500 ;
T1 M06 ;
G00 G90 G54 X1.0 Y-1.0 S3500 M03 ;
G43 H01 Z1.125 M08 ;
G81 G99 Z-1.500 R.05 F20. ;
X2.0 G98 (Will return to starting point after executing cycle)
;
X6.0 G99 (Will return to reference plane after executing
cycle) ;
X8.0 ;
X10.0 ;
X12.0 G98 ;
X16.0 G99 ;
X18.0 G98 ;
G00 G80 Z2.0 M09 ;
G28 G91 Y0 Z0 ;
M30 ;
%
```

## G100 Cancel - G101 Enable Mirror Image (Group 00)

**X** - X-Axis command  
**Y** - Y-Axis command  
**Z** - Z-Axis command  
**A** - A-Axis command

Programmable mirror imaging is used to turn on or off any of the axes. When one is **ON**, axis motion may be mirrored (or reversed) around the work zero point. These G codes should be used in a command block without any other G codes. They do not cause any Y Axis motion. The bottom of the screen will indicate when an axis is mirrored. Also see Settings 45 through 48 for mirror imaging.

The format for turning Mirror Image on and off is:

```
G101 X0. (Will turn on mirror imaging for the X Axis) ;  
G100 X0. (Will turn off mirror imaging for the X Axis) ;
```

### F6.37: X-Y Mirror Image

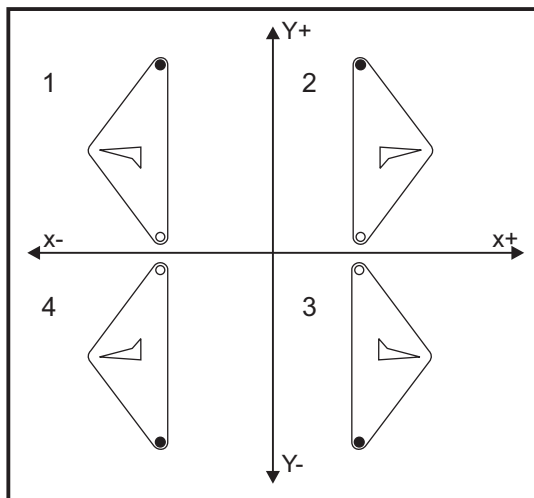

## Mirror Image and Cutter Compensation

Turning on Mirror Image for only one of the X or Y axes will cause the cutter to move along the opposite side of a cut. The control will automatically switch the cutter compensation direction (G41, G42) and reverse the circular motion commands (G02, G03) as needed.

When milling a shape with XY motions, turning on Mirror Image for just one of the X or Y axes will change climb milling (G41) to conventional milling (G42) and/or conventional milling to climb milling. As a result, the type of cut or finish may not be what was desired. Mirror imaging of both X and Y will eliminate this problem.

### F6.38: Mirror Image and Pocket Milling

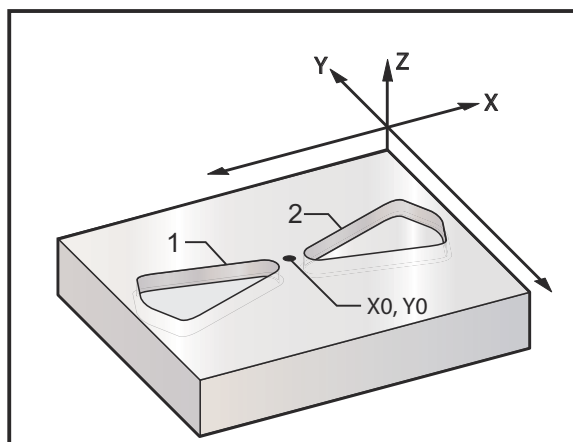

### Program Code for Mirror Imaging in the X-Axis:

```

%
O3600 (Mirror image X Axis) ;
T1 M06 (Tool #1 is a 0.250" diameter endmill) ;
G00 G90 G54 X-.4653 Y.052 S5000 M03 ;
G43 H01 Z.1 M08 ;
G01 Z-.25 F5. ;
M98 P3601 F20. ;
G00 Z.1 ;
G101 X0. ;
X-.4653 Y.052 ;
G01 Z-.25 F5. ;
M98 P3601 F20. ;
G00 Z.1 ;
G100 X0. ;
G28 G91 Y0 Z0 ;
M30 ;
%
```

```
%  
O3601 (Contour subprogram) ;  
G01 X-1.2153 Y.552 ;  
G03 X-1.3059 Y.528 R.0625 ;  
G01 X-1.5559 Y.028 ;  
G03 X-1.5559 Y-.028 R.0625 ;  
G01 X-1.3059 Y-.528 ;  
G03 X-1.2153 Y-.552 R.0625 ;  
G01 X-.4653 Y-.052 ;  
G03 X-.4653 Y.052 R.0625 ;  
M99 ;  
%
```

## G102 Programmable Output to RS-232 (Group 00)

**X** - X-Axis command  
**Y** - Y-Axis command  
**Z** - Z-Axis command  
**A** - A-Axis command

Commanding a G102 will send the current work coordinates of the axes to the first RS-232 port, from there a computer is used to record the values sent. Each axis listed in the G102 command block is output to the RS-232 port in the same format as values displayed in a program. A G102 should be used in a command block without any other G-codes. It will not cause any axis motion; the value for the axes have no effect.

Also see Setting 41 and Setting 25. The values sent out are always the current axis positions referenced to the current work coordinate system.

This G-code is useful in order to probe a part (also see G31). When the probe touches the part, the next line of code could be a G102 to send the axes position to a computer in order to store the coordinates. This is referred to as digitizing a part, which is taking a tangible part and making an electronic copy of it. Additional software for personal computers is required to complete this function.

## G103 Limit Block Buffering (Group 00)

Maximum number of blocks the control will look ahead (Range 0-15), for example:

```
G103 [P..] ;
```

This is commonly referred to, as Block Look-ahead which is a term used to describe what the control is doing in the background during machine motions. The control prepares future blocks (lines of code) ahead of time. While the current block is executing, the next block has already been interpreted and prepared for continuous motion.

When `G103 P0` is programmed, block limiting is disabled. Block limiting is also disabled if `G103` appears in a block without a `P` address code. When `G103 Pn` is programmed, look-ahead is limited to `n` blocks.

`G103` is also useful for debugging macro programs. Macro expressions are done during look-ahead time. For example, by inserting a `G103 P1` into the program, macro expressions will be performed one block ahead of the currently executing block.

## G107 Cylindrical Mapping (Group 00)

**X** - X-Axis command  
**Y** - Y-Axis command  
**Z** - Z-Axis command  
**A** - A-Axis command  
**B** - B-Axis command  
**Q** - Diameter of the cylindrical surface  
**R** - Radius of the rotary Axis

This G code translates all programmed motion occurring in a specified linear axis into the equivalent motion along the surface of a cylinder (as attached to a rotary axis) as shown in the following figure. It is a Group 0 G code, but its default operation is subject to Setting 56 (M30 Restores Default G). The `G107` command is used to either activate or deactivate cylindrical mapping.

- Any linear-axis program can be cylindrically mapped to any rotary axis (one at a time).
- An existing linear-axis G-code program can be cylindrically mapped by inserting a `G107` command at the beginning of the program.
- The radius (or diameter) of the cylindrical surface can be redefined, allowing cylindrical mapping to occur along surfaces of different diameters without having to change the program.
- The radius (or diameter) of the cylindrical surface can either be synchronized with or be independent of the rotary Axis diameter(s) specified in the Settings 34 and 79.
- `G107` can also be used to set the default diameter of a cylindrical surface, independently of any cylindrical mapping that may be in effect.

## G107 Description

Three address codes can follow a `G107`: `X`, `Y` or `Z`; `A` or `B`; and `Q` or `R`.

**X, Y, or Z:** An `X`, `Y`, or `Z` address specifies the linear axis that will be mapped to the specified rotary axis (`A` or `B`). When one of these linear axes is specified, a rotary axis must also be specified.

**A or B:** An `A` or `B` address identifies which rotary Axis holds the cylindrical surface.

Q or R: Q defines the diameter of the cylindrical surface, while R defines the radius. When Q or R is used, a rotary Axis must also be specified. If neither Q nor R is used, then the last G107 diameter is used. If no G107 command has been issued since power-up, or if the last value specified was zero, then the diameter will be the value in Setting 34 and/or 79 for this rotary Axis. When Q or R is specified, that value will become the new G107 value for the specified rotary axis.

Cylindrical mapping will also be turned off automatically whenever the G-code program ends, but only if Setting 56 is ON. Pressing **[RESET]** turns off any cylindrical mapping that is currently in effect, regardless of the status of Setting 56.

### F6.39: Cylindrical Mapping Example

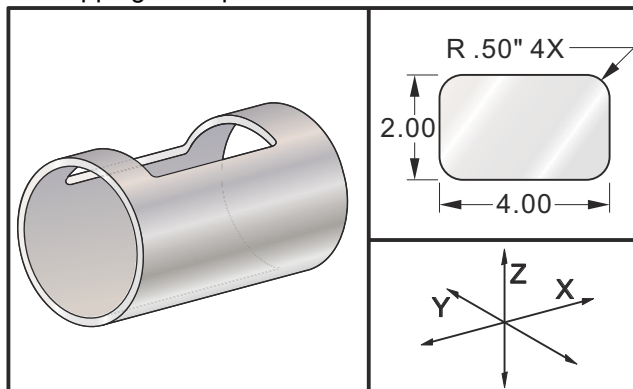

While R is suitable for defining the radius, it is recommended that I, J and K are used for more complex G02 and G03 programming.

### Example

```
%  
O0079 (G107 TEST)  
T1 M06 (.625 DIA. 2FL E.M.)  
G00 G40 G49 G80 G90  
G28 G91 A0  
G90  
G00 G54 X1.5 Y0 S5000 M03  
G107 A0 Y0 R2. (IF NO R OR Q VALUE, MACHINE WILL USE VALUE IN  
SETTING 34)  
G43 H01 Z0.25  
G01 Z-0.25 F25.  
G41 D01 X2. Y0.5  
G03 X1.5 Y1. R0.5  
G01 X-1.5  
G03 X-2. Y0.5 R0.5  
G01 Y-0.5  
G03 X-1.5 Y-1. R0.5
```



```

G01 X1.5
G03 X2. Y-0.5 R0.5
G01 Y0.
G40 X1.5
G00 Z0.25
M09
M05
G91 G28 Z0.
G28 Y0.
G90
G107
M30
%
```

## G110-G129 Coordinate System #7-26 (Group 12)

These codes select one of the additional work coordinate systems. All subsequent references to axis positions will be interpreted in the new coordinate system. Operation of G110 to G129 is the same as G54 to G59.

## G136 Automatic Work Offset Center Measurement (Group 00)

This G-code is optional and requires a probe. Use it to set work offsets to the center of a work piece with a work probe.

- F** - Feedrate
- I** - Optional offset distance along X-Axis
- J** - Optional offset distance along Y-Axis
- K** - Optional offset distance along Z-Axis
- X** - Optional X-Axis motion command
- Y** - Optional Y-Axis motion command
- Z** - Optional Z-Axis motion command

Automatic Work Offset Center Measurement (G136) is used to command a spindle probe to set work offsets. A G136 will feed the axes of the machine in an effort to probe the work piece with a spindle mounted probe. The axis (axes) will move until a signal (skip signal) from the probe is received or the end of the programmed move is reached. Tool compensation (G41, G42, G43, or G44) must not be active when this function is performed. The currently active work coordinate system is set for each axis programmed. Use a G31 cycle with an M75 to set the first point. A G136 will set the work coordinates to a point at the center of a line between the probed point and the point set with an M75. This allows the center of the part to be found using two separate probed points.

If an I, J, or K is specified, the appropriate axis work offset is shifted by the amount in the I, J, or K command. This allows the work offset to be shifted away from the measured center of the two probed points.

### Notes:

This code is non-modal and only applies to the block of code in which G136 is specified.

The points probed are offset by the values in Settings 59 through 62. See the Settings section of this manual for more information.

Do not use Cutter Compensation (G41, G42) with a G136.

Do not use tool length Compensation (G43, G44) with G136

To avoid damaging the probe, use a feed rate below F100. (inch) or F2500. (metric).

Turn on the spindle probe before using G136.

If your mill has the standard Renishaw probing system, use the following commands to turn on the spindle probe:

```
M59 P1134 ;
```

Use the following commands to turn off the spindle probe:

```
M69 P1134 ;
```

Also see M75, M78, and M79.

Also see G31.

This sample program measures the center of a part in the Y Axis and records the measured value to the G58 Y Axis work offset. To use this program, the G58 work offset location must be set at or close to the center of the part to be measured.

```
O00136 (G136 PROGRAM) ;
T30 M06 ;
G00 G90 G58 X0. Y1. ;
M59 P1134 ;
Z-19. ;
G91 G01 Z-1. F20. ;
G31 Y-1. F10. M75 ;
G01 Y0.25 F20. ;
G00 Z2. ;
Y-2. ;
G01 Z-2. F20. ;
G136 Y1. F10. ;
G01 Y-0.25 ;
G00 Z1. ;
G90 ;
```

```
M69 P1134 ;
G00 G53 Z0. ;
M30 ;
```

## G141 3D+ Cutter Compensation (Group 07)

**X** - X-Axis command  
**Y** - Y-Axis command  
**Z** - Z-Axis command  
**A** - A-Axis command (optional)  
**B** - B-Axis command (optional)  
**D** - Cutter Size Selection (modal)  
**I** - X-Axis cutter compensation direction from program path  
**J** - Y-Axis cutter compensation direction from program path  
**K** - Z-Axis cutter compensation direction from program path  
**F** - Feedrate

This feature performs three-dimensional cutter compensation.

The form is:

```
G141 Xnnn Ynnn Znnn Innn Jnnn Knnn Fnnn Dnnn
```

Subsequent lines can be:

```
G01 Xnnn Ynnn Znnn Innn Jnnn Knnn Fnnn ;
```

Or

```
G00 Xnnn Ynnn Znnn Innn Jnnn Knnn ;
```

Some CAM systems are able to output the X, Y, and Z with values for I, J, K. The I, J, and K values tell the control the direction in which to apply the compensation at the machine. Similar to other uses of I, J, and K, these are incremental distances from the X, Y, and Z point called.

The I, J, and K specify the normal direction, relative to the center of the tool, to the contact point of the tool in the CAM system. The I, J, and K vectors are required by the control to be able to shift the toolpath in the correct direction. The value of the compensation can be in a positive or negative direction.

The offset amount entered in radius or diameter (Setting 40) for the tool will compensate the path by this amount, even if the tool motions are 2 or 3 axes. Only G00 and G01 can use G141. A Dnn will have to be programmed; the D-code selects which tool wear diameter offset to use. A feedrate must be programmed on each line if in G93 Inverse Time Feed mode.

With a unit vector, the length of the vector line must always equal 1. In the same way that a unit circle in mathematics is a circle with a radius of 1, a unit vector is a line that indicates a direction with a length of 1. Remember, the vector line does not tell the control how far to move the tool when a wear value is entered, just the direction in which to go.

Only the endpoint of the commanded block is compensated in the direction of I, J, and K. For this reason, this compensation is recommended only for surface toolpaths having a tight tolerance (small motion between blocks of code). G141 compensation does not prohibit the toolpath from crossing over itself when excessive cutter compensation is entered. The tool will be offset, in the direction of the vector line, by the combined values of the tool offset geometry plus the tool offset wear. If compensation values are in diameter mode (Setting 40), the move will be half the amount entered in these fields.

For best results, program from the tool center using a ball nose endmill.

G141 Example:

```
N1 T1 M06 ;
N2 G00 G90 G54 X0 Y0 Z0 A0 B0 ;
N3 G141 D01 X0.Y0. Z0. (RAPID POSIT WITH 3 AX C COMP) ;
N4 G01 G93 X.01 Y.01 Z.01 I.1 J.2 K.9747 F300. (FEED INV TIME)
;
N5 X.02 Y.03 Z.04 I.15 J.25 K.9566 F300. ;
N6 X.02 Y.055 Z.064 I.2 J.3 K.9327 F300. ;
... ;
N10 X2.345 Y.1234 Z-1.234 I.25 J.35 K.9028 F200. (LAST MOTION)
;
N11 G94 F50. (CANCEL G93) ;
N12 G0 G90 G40 Z0 (Rapid to Zero, Cancel Cutter Comp) ;
N13 X0 Y0 ;
N14 M30 ;
```

In the above example, we can see where the I, J, and K were derived by plugging the points into the following formula:

$AB = [(x_2-x_1)^2 + (y_2-y_1)^2 + (z_2-z_1)^2]$ , a 3D version of the distance formula. Looking at line N5, we will use 0.15 for  $x_2$ , 0.25 for  $y_2$ , and 0.9566 for  $Z_2$ . Because I, J, and K are incremental, we will use 0 for  $x_1$ ,  $y_1$ , and  $z_1$ .

**F6.40:** Unit Vector Example: The commanded line endpoint [1] is compensated in the direction of the vector line [2](I,J,K), by the amount of the Tool Offset Wear.

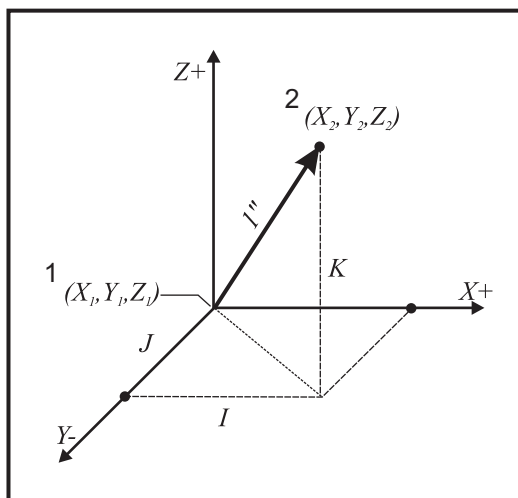

```

AB=[ (.15)2 + (.25)2 + (.9566)2]
AB=[ .0225 + .0625 + .9151]
AB=1
AB=1

```

A simplified example is listed below:

```

N1 T1 M06 ;
N2 G00 G90 G54 X0 Y0 ;
N3 G43 H01 Z1. ;
N4 G141 D01 X0. Y0. Z0. (RAPID POSIT WITH 3 AX C COMP) ;
N5 G01 X10. Y0 I0. J-1. K0. F300. ;
N6 G40 Z1.0 (Rapid to Zero, Cancel Cutter Comp) ;
N7 M30 ;

```

In this case, if the wear value (DIA) for T01 is set to -.02, then the tool will move from X0. Y0. Z0. (Line N4) to X10. Y.01. The J value told the control to compensate the endpoint of the programmed line only in the Y Axis.

Line N5 could have been written using only the J-1. (not using I0. K0.), but a Y value must be entered if a compensation is to be made in this axis (J value used).

## G143 5-Axis Tool Length Compensation + (Group 08)

(This G-code is optional; it only applies to machines on which all rotary motion is movement of the cutting tool, such as VR-series mills)

This G code allows the user to correct for variations in the length of cutting tools without the need for a CAD/CAM processor. An H code is required to select the tool length from the existing length compensation tables. A G49 or H00 command will cancel 5-axis compensation. For G143 to work correctly there must be two rotary axes, A and B. G90, absolute positioning mode must be active (G91 cannot be used). Work position 0,0 for the A and B axes must be so the tool is parallel with Z-Axis motion.

The intention behind G143 is to compensate for the difference in tool length between the originally posted tool and a substitute tool. Using G143 allows the program to run without having to repost a new tool length.

G143 tool length compensation works only with rapid (G00) and linear feed (G01) motions; no other feed functions (G02 or G03) or canned cycles (drilling, tapping, etc.) can be used. For a positive tool length, the Z-Axis would move upward (in the + direction). If one of X, Y or Z is not programmed, there will be no motion of that axis, even if the motion of A or B produces a new tool length vector. Thus a typical program would use all 5 axes on one block of data. G143 may effect commanded motion of all axes in order to compensate for the A and B axes.

Inverse feed mode (G93) is recommended, when using G143. An example follows:

```
T1 M06 ;
G00 G90 G54 X0 Y0 Z0 A0 B0 ;
G143 H01 X0. Y0. Z0. A-20. B-20. (RAPID POSIT W. 5AX COMP) ;
G01 G93 X.01 Y.01 Z.01 A-19.9 B-19.9 F300. (FEED INV TIME) ;
X0.02 Y0.03 Z0.04 A-19.7 B-19.7 F300. ;
X0.02 Y0.055 Z0.064 A-19.5 B-19.6 F300. ;
X2.345 Y.1234 Z-1.234 A-4.127 B-12.32 F200. (LAST MOTION) ;
G94 F50. (CANCEL G93) ;
G00 G90 G49 Z0 (RAPID TO ZERO, CANCEL 5 AXS COMP) ;
X0 Y0 ;
M30 ;
```

## G150 General Purpose Pocket Milling (Group 00)

**D** - Tool radius/diameter offset selection  
**F** - Feedrate  
**I** - X-Axis cut increment (positive value)  
**J** - Y-Axis cut increment (positive value)  
**K** - Finishing pass amount (positive value)  
**P** - Subprogram number that defines pocket geometry  
**Q** - Incremental Z-Axis cut depth per pass (positive value)  
**R** - Position of the rapid R-plane location  
**S** - Optional spindle speed  
**X** - X start position  
**Y** - Y start position  
**Z** - Final depth of pocket

The G150 starts by positioning the cutter to a start point inside the pocket, followed by the outline, and completes with a finish cut. The end mill will plunge in the Z-Axis. A subprogram P### is called, which defines the pocket geometry of a closed area using G01, G02, and G03 motions in the X and Y axes on the pocket. The G150 command will search for an internal subprogram with a N-number specified by the P-code. If that is not found the control will search for an external subprogram. If neither are found, alarm 314 Subprogram Not In Memory will be generated.



### NOTE:

*When defining the G150 pocket geometry in the subprogram, do not move back to the starting hole after the pocket shape is closed.*

An **I** or **J** value defines the roughing pass amount the cutter moves over for each cut increment. If **I** is used, the pocket is roughed out from a series of increment cuts in the X-Axis. If **J** is used, the increment cuts are in the Y-Axis.

The **K** command defines a finish pass amount on the pocket. If a **K** value is specified, a finish pass is performed by **K** amount, around the inside of pocket geometry for the last pass and is done at the final Z depth. There is no finishing pass command for the Z depth.

The **R** value needs to be specified, even if it is zero ( R0), or the last **R** value that was specified will be used.

Multiple passes in the pocket area are done, starting from the R plane, with each Q (Z-Axis depth) pass to the final depth. The G150 command will first make a pass around pocket geometry, leaving stock with **K**, then doing passes of **I** or **J** roughing out inside of pocket after feeding down by the value in Q until the Z depth is reached.

The Q command must be in the G150 line, even if only one pass to the Z depth is desired. The Q command starts from the R plane.

Notes: The subprogram (P) must not consist of more than 40 pocket geometry moves.

It may be necessary to drill a starting point, for the G150 cutter, to the final depth (Z). Then position the end mill to the start location in the XY axes within the pocket for the G150 command.

**F6.41:** G150 General Pocket Milling: [1] Start Point, [Z] Final depth.

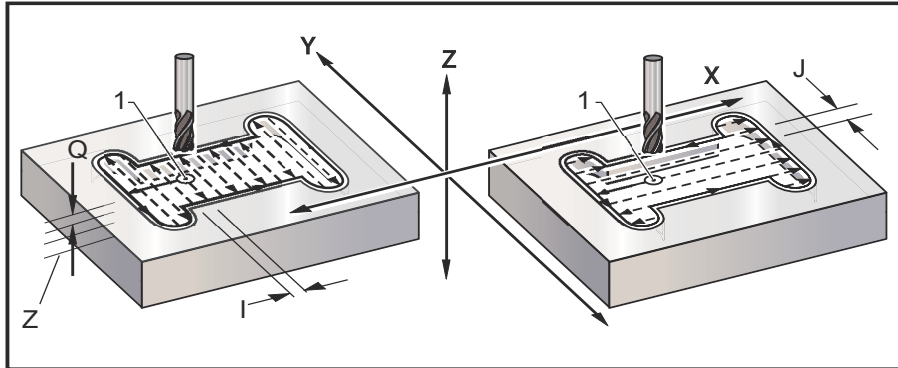

### Example

```
O01001 (G150 Pocket example) ;
T1 M06 (T1 Drills clearance hole for endmill) ;
G90 G54 G00 X3.25 Y4.5 S1200 (Pocket start point) ;
M03 ;
G43 H01 Z1.0 M08 (Tool length offset, rapid to Z start point,
coolant on) ;
G83 Z-1.5 Q0.25 R0.1 F20.(Peck drill cycle) ;
G53 G49 Z0 (Returns Z to home position) ;
T2 M06 (.5" Endmill) ;
G54 G90 G00 X3.25 Y4.5 S1450 (Pocket start point) ;
M03 ;
G43 H02 Z1.0 M08 (Tool length offset, rapid to Z start point,
coolant on) ;
G150 X3.25 Y4.5 Z-1.5 G41 J0.35 ;
K.01 Q0.8 R.1 P2001 D02 F15. ;
(0.01" finish pass (K) on sides) ;
G40 X3.25 Y4.5 (Cancel cutter comp. and position back to start
point) ;
G53 G49 Y0 Z0 (Returns Z to home position) ;
M30 (End of main program) ;
O02001 (Separate program as a subprogram for G150 pocket
geometry) ;
G01 Y7 (The first move onto pocket geometry with a G01) ;
X1.5 (The following lines define pocket geometry) ;
G03 Y5.25 R0.875 ;
```



```

G01 Y2.25 ;
G03 Y0.5 R0.875 ;
G01 X5. ;
G03 Y2.25 R0.875 ;
G01 Y5.25 ;
G03 Y7. R0.875 ;
G01 X3.25 (Close pocket geometry. Do not go back to start.) ;
M99 (Return to Main Program) ;

```

### Square Pocket

**F6.42:** G150 General Purpose Pocket Milling: 0.500 diameter endmill.

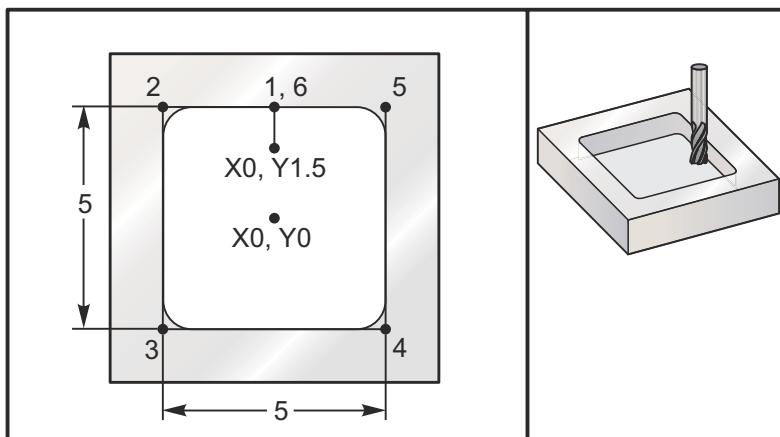

### 5.0 x 5.0 x 0.500 DP. Square Pocket

#### Main Program

```

%
O01001 ;
T1 M06 (Tool #1 is a 0.500" diameter endmill) ;
G90 G54 G00 X0. Y1.5 (XY Start Point) ;
S2000 M03 ;
G43 H01 Z0.1 M08 ;
G01 Z0.1 F10. ;
G150 P1002 Z-0.5 Q0.25 R0.01 J0.3 K0.01 G41 D01 F10. ;
G40 G01 X0. Y1.5 ;
G00 Z1. M09 ;
G53 G49 Y0. Z0. ;
M30 ;
%

```

#### Subprogram

```
%  
O01002 ;  
G01 Y2.5 (1) ;  
X-2.5 (2) ;  
Y-2.5 (3) ;  
X2.5 (4) ;  
Y2.5 (5) ;  
X0. (6) (Close Pocket Loop) ;  
M99 (Return to Main Program) ;  
%
```

**Absolute and Incremental examples of a subprogram called up by the P#### command in the G150 line:**

### **Absolute Subprogram**

```
%  
O01002 (G90 Subprogram for G150) ;  
G90 G01 Y2.5 (1) ;  
X-2.5 (2) ;  
Y-2.5 (3) ;  
X2.5 (4) ;  
Y2.5 (5) ;  
X0. (6) ;  
M99 ;  
%
```

### **Incremental Subprogram**

```
%  
O01002 (G91 Subprogram for G150) ;  
G91 G01 Y0.5 (1) ;  
X-2.5 (2) ;  
Y-5. (3) ;  
X5. (4) ;  
Y5. (5) ;  
X-2.5 (6) ;  
G90 ;  
M99 ;  
%
```

### **Square Island**

**F6.43:** G150 Pocket Milling Square Island: 0.500 diameter endmill.

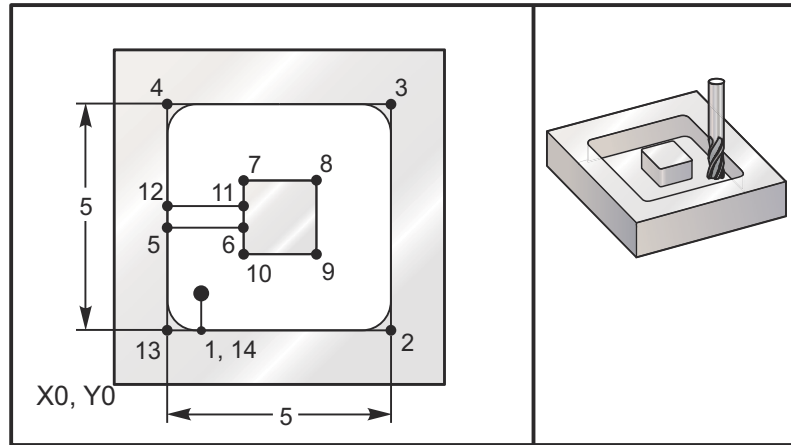

### 5.0 x 5.0 x 0.500 DP. Square Pocket with Square Island

#### Main Program

```

%
O02010 ;
T1 M06 (Tool is a 0.500" diameter endmill) ;
G90 G54 G00 X2. Y2. (XY Start Point) ;
S2500 M03 ;
G43 H01 Z0.1 M08 ;
G01 Z0.01 F30. ;
G150 P2020 X2. Y2. Z-0.5 Q0.5 R0.01 I0.3 ;
K0.01 G41 D01 F10. ;
G40 G01 X2.Y2. ;
G00 Z1.0 M09 ;
G53 G49 Y0. Z0. ;
M30 ;

```

#### Subprogram

```

%
O02020 (Subprogram for G150 in O02010) ;
G01 Y1. (1) ;
X6. (2) ;
Y6. (3) ;
X1. (4) ;
Y3.2 (5) ;
X2.75 (6) ;
Y4.25 (7) ;
X4.25 (8) ;
Y2.75 (9) ;

```

```
X2.75 (10) ;  
Y3.8 (11) ;  
X1. (12) ;  
Y1. (13) ;  
X2. (14) (Close Pocket Loop) ;  
M99 (Return to Main Program) ;  
%
```

### Round Island

**F6.44:** G150 Pocket Milling Round Island: 0.500 diameter endmill.

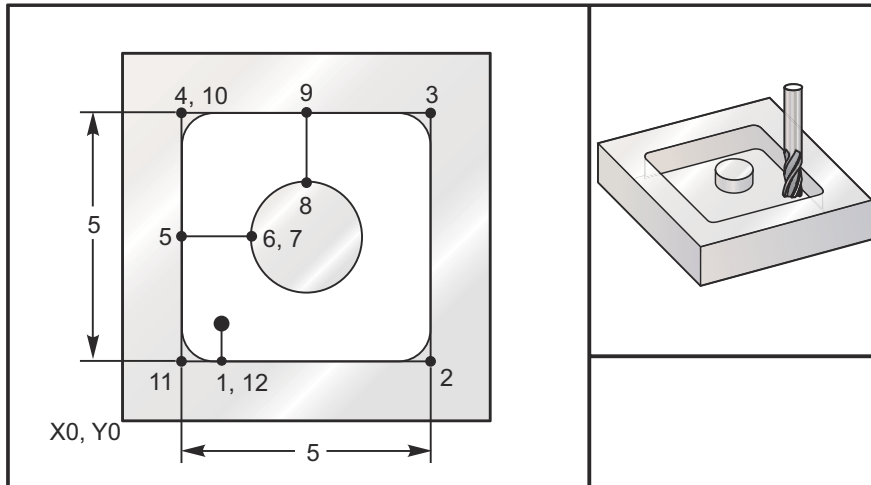

### 5.0 x 5.0 x 0.500 DP. Square Pocket with Round Island

#### Main Program

```
%  
O03010 ;  
T1 M06 (Tool is a 0.500" diameter endmill) ;  
G90 G54 G00 X2. Y2. (XY Start Point) ;  
S2500 M03 ;  
G43 H01 Z0.1 M08 ;  
G01 Z0. F30. ;  
G150 P3020 X2. Y2. Z-0.5 Q0.5 R0.01 J0.3 ;  
K0.01 G41 D01 F10. ;  
G40 G01 X2. Y2. ;  
G00 Z1. M09 ;  
G53 G49 Y0. Z0. ;  
M30 ;  
%
```

**Subprogram**

```
%  
O03020 (Subprogram for G150 in O03010) ;  
G01 Y1. (1) ;  
X6. (2) ;  
Y6. (3) ;  
X1. (4) ;  
Y3.5 (5) ;  
X2.5 (6) ;  
G02 I1. (7) ;  
G02 X3.5 Y4.5 R1. (8) ;  
G01 Y6. (9) ;  
X1. (10) ;  
Y1. (11) ;  
X2. (12) (Close Pocket Loop) ;  
M99 (Return to Main Program) ;  
%
```

## G153 5-Axis High Speed Peck Drilling Canned Cycle (Group 09)

- E - Specifies the distance from the start position to the bottom of the hole (must be a positive value)
- F - Feedrate
- I - Size of first cutting depth (must be a positive value)
- J - Amount to reduce cutting depth each pass (must be a positive value)
- K - Minimum depth of cut (must be a positive value)
- L - Number of repeats
- P - Pause at end of last peck, in seconds
- Q - The cut-in value (must be a positive value)
- A - A-Axis tool starting position
- B - B-Axis tool starting position
- X - X-Axis tool starting position
- Y - Y-Axis tool starting position
- Z - Z-Axis tool starting position

### F6.45: G153 5-Axis High Speed Peck Drilling: [#22] Setting 22.

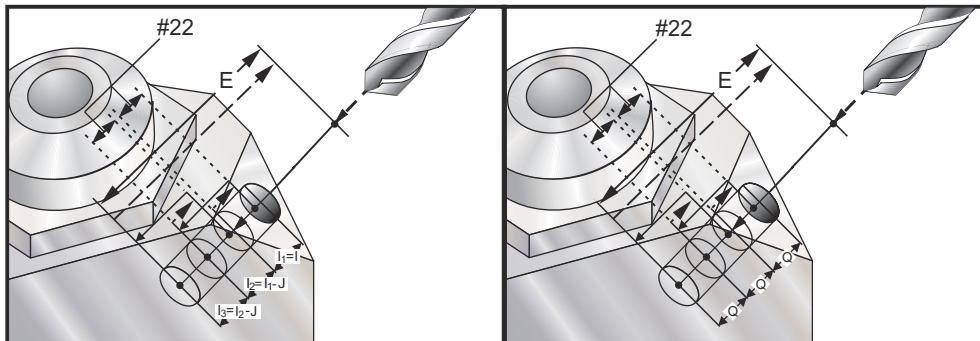

This is a high-speed peck cycle where the retract distance is set by Setting 22.

If  $I$ ,  $J$ , and  $K$  are specified, a different operating mode is selected. The first pass will cut in by amount  $I$ , each succeeding cut will be reduced by amount  $J$ , and the minimum cutting depth is  $K$ . If  $P$  is used, the tool will pause at the bottom of the hole for that amount of time.



#### NOTE:

*The same dwell time applies to all subsequent blocks that do not specify a dwell time.*

## G154 Select Work Coordinates P1-P99 (Group 12)

This feature provides 99 additional work offsets. G154 with a P value from 1 to 99 activates additional work offsets. For example G154 P10 selects work offset 10 from the list of additional work offsets.



**NOTE:**

*G110 to G129 refer to the same work offsets as G154 P1 through P20; they can be selected by using either method.*

When a G154 work offset is active, the heading in the upper right work offset will show the G154 P value.

### G154 work offsets format

```
#14001-#14006 G154 P1 (also #7001-#7006 and G110)
#14021-#14026 G154 P2 (also #7021-#7026 and G111)
#14041-#14046 G154 P3 (also #7041-#7046 and G112)
#14061-#14066 G154 P4 (also #7061-#7066 and G113)
#14081-#14086 G154 P5 (also #7081-#7086 and G114)
#14101-#14106 G154 P6 (also #7101-#7106 and G115)
#14121-#14126 G154 P7 (also #7121-#7126 and G116)
#14141-#14146 G154 P8 (also #7141-#7146 and G117)
#14161-#14166 G154 P9 (also #7161-#7166 and G118)
#14181-#14186 G154 P10 (also #7181-#7186 and G119)
#14201-#14206 G154 P11 (also #7201-#7206 and G120)
#14221-#14221 G154 P12 (also #7221-#7226 and G121)
#14241-#14246 G154 P13 (also #7241-#7246 and G122)
#14261-#14266 G154 P14 (also #7261-#7266 and G123)
#14281-#14286 G154 P15 (also #7281-#7286 and G124)
#14301-#14306 G154 P16 (also #7301-#7306 and G125)
#14321-#14326 G154 P17 (also #7321-#7326 and G126)
#14341-#14346 G154 P18 (also #7341-#7346 and G127)
#14361-#14366 G154 P19 (also #7361-#7366 and G128)
#14381-#14386 G154 P20 (also #7381-#7386 and G129)
#14401-#14406 G154 P21
#14421-#14426 G154 P22
#14441-#14446 G154 P23
#14461-#14466 G154 P24
#14481-#14486 G154 P25
#14501-#14506 G154 P26
#14521-#14526 G154 P27
#14541-#14546 G154 P28
#14561-#14566 G154 P29
#14581-#14586 G154 P30
#14781-#14786 G154 P40
```

```
#14981-#14986 G154 P50  
#15181-#15186 G154 P60  
#15381-#15386 G154 P70  
#15581-#15586 G154 P80  
#15781-#15786 G154 P90  
#15881-#15886 G154 P95  
#15901-#15906 G154 P96  
#15921-#15926 G154 P97  
#15941-#15946 G154 P98  
#15961-#15966 G154 P99
```

## **G155 5-Axis Reverse Tap Canned Cycle (Group 09)**

G155 performs only floating taps. G174 is available for 5-axis reverse rigid tapping.

**E** - Specifies the distance from the start position to the bottom of the hole (must be a positive value)

**F** - Feedrate

**L** - Number of repeats

**A** - A-Axis tool starting position

**B** - B-Axis tool starting position

**X** - X-Axis tool starting position

**Y** - Y-Axis tool starting position

**Z** - Z-Axis tool starting position

**S** - Spindle Speed

A specific X, Y, Z, A, B position must be programmed before the canned cycle is commanded. This position is used as the Initial Start position. The control automatically starts the spindle counterclockwise before this canned cycle.

**F6.46:** G155 5-Axis Reverse Tap Canned Cycle

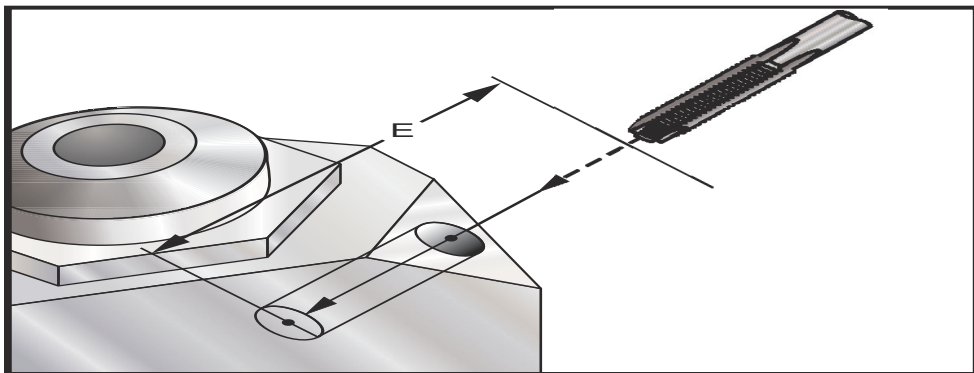



## G161 5-Axis Drill Canned Cycle (Group 09)

**E** - Specifies the distance from the start position to the bottom of the hole (must be a positive value)

**F** - Feedrate

**A** - A-Axis tool starting position

**B** - B-Axis tool starting position

**X** - X-Axis tool starting position

**Y** - Y-Axis tool starting position

**Z** - Z-Axis tool starting position

**F6.47:** G161 5-Axis Drill Canned Cycle

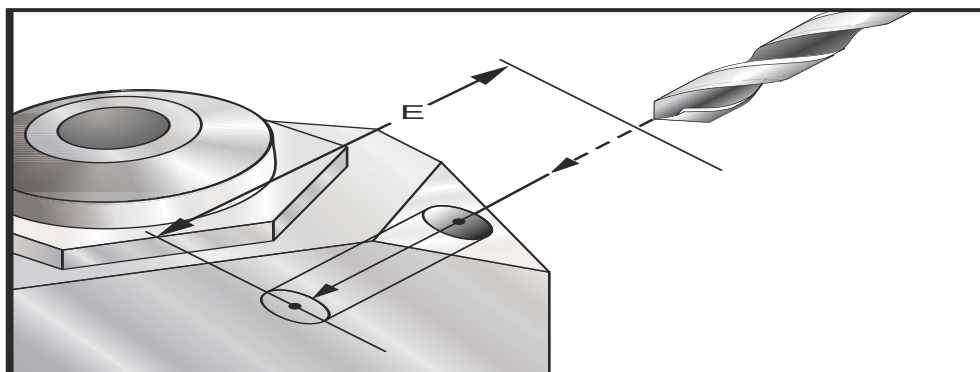

A specific X, Y, Z, A, B position must be programmed before the canned cycle is commanded.

Example

```
(DRILL RIGHT, FRONT) ;
T4 M6 ;
G01 G54 G90 X8.4221 Y-8.4221 B23. A21.342 S2200 M3 F360.
(Clearance Position) ;
G143 H4 Z14.6228 M8 ;
G1 X6.6934 Y-6.6934 Z10.5503 F360. (Initial Start position) ;
G161 E.52 F7. (Canned Cycle) ;
G80 ;
X8.4221 Y-8.4221 B23. A21.342 Z14.6228 (Clearance Position) ;
M5 ;
G1 G28 G91 Z0. ;
G91 G28 B0. A0. ;
M01 ;
```

## G162 5-Axis Spot Drill Canned Cycle (Group 09)

**E** - Specifies the distance from the start position to the bottom of the hole (must be a positive value)

**F** - Feedrate

**P** - The dwell time at the bottom of the hole

**A** - A-Axis tool starting position

**B** - B-Axis tool starting position

**X** - X-Axis tool starting position

**Y** - Y-Axis tool starting position

**Z** - Z-Axis tool starting position

A specific X, Y, Z, A, B position must be programmed before the canned cycle is commanded.

Example

```
(COUNTER DRILL RIGHT, FRONT) ;  
T2 M6 ;  
G01 G54 G90 X8.4221 Y-8.4221 B23. A21.342 S2200 M3 F360.  
(Clearance Position) ;  
G143 H2 Z14.6228 M8 ;  
G1 X6.6934 Y-6.6934 Z10.5503 F360. (Initial Start position) ;  
G162 E.52 P2.0 F7. (Canned Cycle) ;  
G80 ;  
X8.4221 Y-8.4221 B23. A21.342 Z14.6228 (Clearance Position) ;  
M5 ;  
G1 G28 G91 Z0. ;  
G91 G28 B0. A0. ;  
M01 ;
```

**F6.48:** G162 Spot Drill Canned Cycle

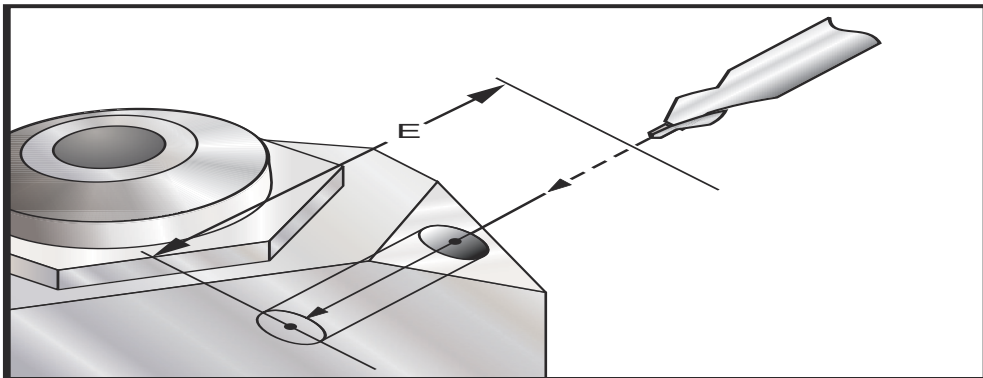

## G163 5-Axis Normal Peck Drilling Canned Cycle (Group 09)

- E** - Specifies the distance from the start position to the bottom of the hole (must be a positive value)
- F** - Feedrate
- I** - Optional size of first cutting depth
- J** - Optional amount to reduce cutting depth each pass
- K** - Optional minimum depth of cut
- P** - Optional pause at end of last peck, in seconds
- Q** - The cut-in value, always incremental
- A** - A-Axis tool starting position
- B** - B-Axis tool starting position
- X** - X-Axis tool starting position
- Y** - Y-Axis tool starting position
- Z** - Z-Axis tool starting position

A specific X, Y, Z, A, B position must be programmed before the canned cycle is commanded.

If I, J, and K are specified the first pass will cut in by amount I, each succeeding cut will be reduced by amount J, and the minimum cutting depth is K.

A P value is used the tool will pause at the bottom of the hole after the last peck for that amount of time. The following example will peck several times and dwell for one and a half seconds at the end:

```
G163 E0.62 F15. Q0.175 P1.5.
```



**NOTE:**

*The same dwell time applies to all subsequent blocks that do not specify a dwell time.*

**F6.49:** G163 5-Axis Normal Peck Drilling Canned Cycle: [#22] Setting 22, [#52] Setting 52.

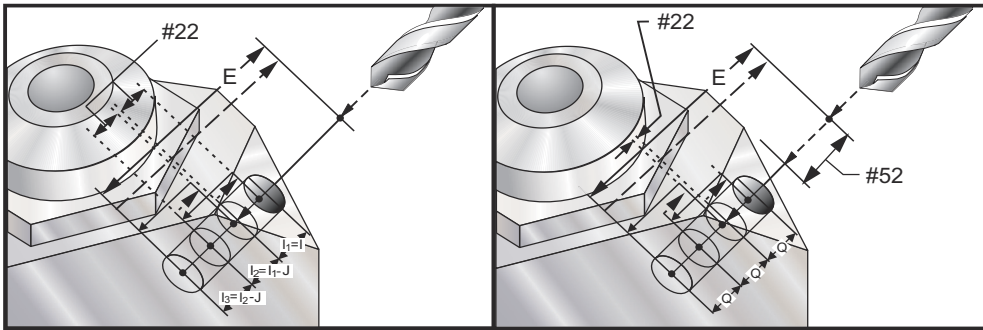

Setting 52 also changes the way G163 works when it returns to the start position. Usually the R plane is set well above the cut to ensure that the peck motion allows the chips to get out of the hole. This wastes time as the drill starts by drilling empty space. If Setting 52 is set to the distance required to clear chips, the start position can be put much closer to the part being drilled. When the chip-clearing move to the start position occurs, the Z axis will be moved above the start position by the amount given in this setting.

**Example**

```
(PECK DRILL RIGHT, FRONT) ;
T5 M6 ;
G01 G54 G90 X8.4221 Y-8.4221 B23. A21.342 S2200 M3 F360.
(Clearance Position) ;
G143 H5 Z14.6228 M8 ;
G1 X6.6934 Y-6.6934 Z10.5503 F360. (Initial Start position) ;
G163 E1.0 Q.15 F12. (Canned Cycle) ;
G80 ;
X8.4221 Y-8.4221 B23. A21.342 Z14.6228 (Clearance Position) ;
M5 ;
G1 G28 G91 Z0. ;
G91 G28 B0. A0. ;
M01 ;
```

## G164 5-Axis Tapping Canned Cycle (Group 09)

G164 performs only floating taps. G174/G184 is available for 5-axis rigid tapping.

**E** - Specifies the distance from the start position to the bottom of the hole (must be a positive value)

**F** - Feedrate

**A** - A-Axis tool starting position

**B** - B-Axis tool starting position

**X** - X-Axis tool starting position

**Y** - Y-Axis tool starting position

**Z** - Z-Axis tool starting position

**S** - Spindle Speed

### F6.50: G164 5-Axis Tapping Canned Cycle

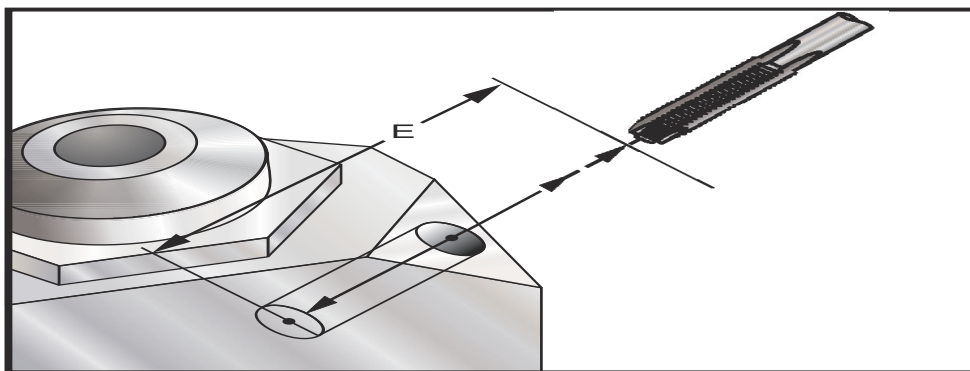

A specific X, Y, Z, A, B position must be programmed before the canned cycle is commanded. The control will automatically start the spindle CW before this canned cycle.

### Example

```
(1/2-13 TAP) ;
T5 M6 ;
G01 G54 G90 X8.4221 Y-8.4221 B23. A21.342 S500M3 F360.
(Clearance Position) ;
G143 H5 Z14.6228 M8 ;
G1 X6.6934 Y-6.6934 Z10.5503 F360. (Initial Start position) ;
G164 E1.0 F38.46 (Canned Cycle) ;
G80 ;
X8.4221 Y-8.4221 B23. A21.342 Z14.6228 (Clearance Position) ;
M5 ;
G1 G28 G91 Z0. ;
G91 G28 B0. A0. ;
M01 ;
```

## G165 5-Axis Boring Canned Cycle (Group 09)

**E** - Specifies the distance from the start position to the bottom of the hole (must be a positive value)

**F** - Feedrate

**A** - A-Axis tool starting position

**B** - B-Axis tool starting position

**X** - X-Axis tool starting position

**Y** - Y-Axis tool starting position

**Z** - Z-Axis tool starting position

### F6.51: G165 5-Axis Boring Canned Cycle

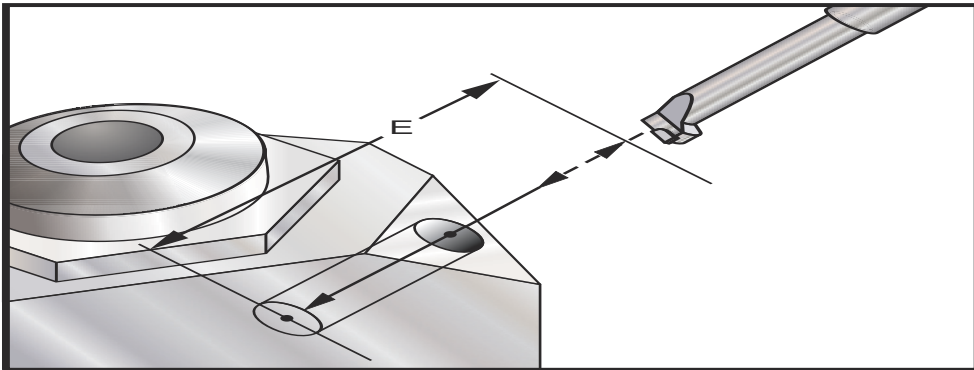

A specific X, Y, Z, A, B position must be programmed before the canned cycle is commanded.

### Example

```
(Boring Cycle) ;  
T5 M6 ;  
G01 G54 G90 X8.4221 Y-8.4221 B23. A21.342 S2200 M3 F360.  
(Clearance Position) ;  
G143 H5 Z14.6228 M8 ;  
G1 X6.6934 Y-6.6934 Z10.5503 F360. (Initial Start position) ;  
G165 E1.0 F12. (Canned Cycle) ;  
G80 ;  
X8.4221 Y-8.4221 B23. A21.342 Z14.6228 (Clearance Position) ;  
M5 ;  
G00 G28 G91 Z0. ;  
G91 G28 B0. A0. ;  
M01 ;
```

## G166 5-Axis Bore and Stop Canned Cycle (Group 09)

**E** - Specifies the distance from the start position to the bottom of the hole (must be a positive value)

**F** - Feedrate

**A** - A-Axis tool starting position

**B** - B-Axis tool starting position

**X** - X-Axis tool starting position

**Y** - Y-Axis tool starting position

**Z** - Z-Axis tool starting position

### F6.52: G166 5-Axis Bore and Stop Canned Cycle

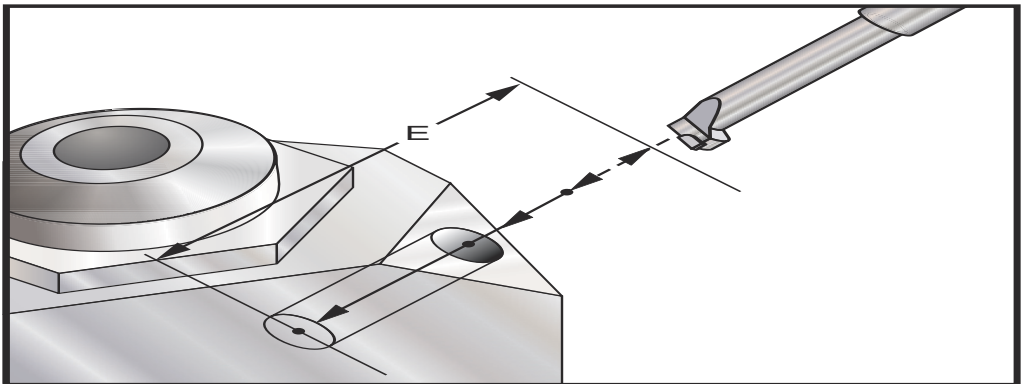

A specific X, Y, Z, A, B position must be programmed before the canned cycle is commanded.

### Example

```
(Bore and Stop Cycle) ;
T5 M6 ;
G01 G54 G90 X8.4221 Y-8.4221 B23. A21.342 S2200 M3 F360.
(Clearance Position) ;
G143 H5 Z14.6228 M8 ;
G1 X6.6934 Y-6.6934 Z10.5503 F360. (Initial Start position) ;
G166 E1.0 F12. (Canned Cycle) ;
G80 ;
X8.4221 Y-8.4221 B23. A21.342 Z14.6228 (Clearance Position) ;
M5 ;
G00 G28 G91 Z0. ;
G91 G28 B0. A0. ;
M01 ;
```

## G169 5-Axis Bore and Dwell Canned Cycle (Group 09)

**E** - Specifies the distance from the start position to the bottom of the hole (must be a positive value)

**F** - Feedrate

**P** - The dwell time at the bottom of the hole

**A** - A-Axis tool starting position

**B** - B-Axis tool starting position

**X** - X-Axis tool starting position

**Y** - Y-Axis tool starting position

**Z** - Z-Axis tool starting position

### F6.53: G169 5-Axis Bore and dwell Canned Cycle

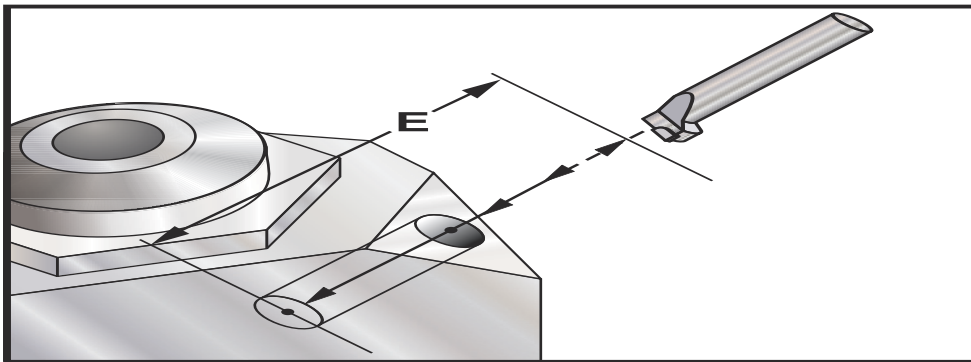

A specific X, Y, Z, A, B position must be programmed before the canned cycle is commanded.

### Example

```
(Bore and Dwell Cycle) ;  
T5 M6 ;  
G01 G54 G90 X8.4221 Y-8.4221 B23. A21.342 S2200 M3 F360.  
(Clearance Position) ;  
G143 H5 Z14.6228 M8 ;  
G1 X6.6934 Y-6.6934 Z10.5503 F360. (Initial Start position) ;  
G169 E1.0 P0.5 F12. (Canned Cycle) ;  
G80 ;  
X8.4221 Y-8.4221 B23. A21.342 Z14.6228 (Clearance Position) ;  
M5 ;  
G00 G28 G91 Z0. ;  
G91 G28 B0. A0. ;  
M01 ;
```



## G174 CCW - G184 CW Non-Vertical Rigid Tap (Group 00)

**F** - Feedrate  
**X** - X position at bottom of hole  
**Y** - Y position at bottom of hole  
**Z** - Z position at bottom of hole  
**S** - Spindle Speed

A specific X, Y, Z, A, B position must be programmed before the canned cycle is commanded. This position is used as the Start position.

This G code is used to perform rigid tapping for non-vertical holes. It may be used with a right-angle head to perform rigid tapping in the X or Y Axis on a three-axis mill, or to perform rigid tapping along an arbitrary angle with a five-axis mill. The ratio between the feedrate and spindle speed must be precisely the thread pitch being cut.

It is not necessary to start the spindle before this canned cycle; the control does this automatically.

## G187 Setting the Smoothness Level (Group 00)

G187 is an accuracy command that can set and control both the smoothness and max corner rounding value when cutting a part. The format for using G187 is G187 Pn Ennnn.

**P** - Controls the smoothness level, P1(rough), P2(medium), or P3(finish). Temporarily overrides Setting 191.

**E** - Sets the max corner rounding value. Temporarily overrides Setting 85.

Setting 191 sets the default smoothness to the user specified **ROUGH**, **MEDIUM**, or **FINISH** when G187 is not active. The **Medium** setting is the factory default setting.



**NOTE:**

*Changing Setting 85 to a low value may make the machine operate as if it is in exact stop mode.*



**NOTE:**

*Changing setting 191 to **FINISH** will take longer to machine a part. Use this setting only when needed for the best finish.*

G187 Pm Ennnn sets both the smoothness and max corner rounding value. G187 Pm sets the smoothness but leaves max corner rounding value at its current value. G187 Ennnn sets the max corner rounding but leaves smoothness at its current value. G187 by itself cancels the E value and sets smoothness to the default smoothness specified by Setting 191. G187 will be canceled whenever [RESET] is pressed, M30 or M02 is executed, the end of program is reached, or [EMERGENCY STOP] is pressed.

## G188 Get Program From PST (Group 00)

Calls the parts program for the loaded pallet based on the Pallet Schedule Table entry for the pallet.

## G234 Tool Center Point Control (TCPC)

G234 Tool Center Point Control (TCPC) is a software feature in the Haas CNC control that allows a machine to correctly run a contouring 4- or 5-axis program when the workpiece is not located in the exact location specified by a CAM-generated program. This eliminates the need to repost a program from the CAM system when the programmed and the actual workpiece locations are different.

For more information refer to the UMC-750 Operator's Manual Supplement.

## G254 Dynamic Work Offset (DWO)

G254 Dynamic Work Offset (DWO) is similar to TCPC, except that it is designed for use with 3+1 or 3+2 positioning, not for simultaneous 4- or 5-axis machining. If the program does not make use of the B and C Axes, there is no need to use DWO.

For more information refer to the UMC-750 Operator's Manual Supplement.

## G255 Cancel Dynamic Work Offset (DWO)

G255 cancels G254 Dynamic Work Offset (DWO)

For more information refer to the UMC-750 Operator's Manual Supplement.

## 6.3 M-codes

These M-code descriptions are valid for the Haas Mill and are listed in numerical order.

<b>Code</b>	<b>Description</b>	<b>Page</b>
M00	Stop Program	322
M01	Optional Program Stop	322
M02	Program End	323
M03	Spindle Commands	323
M04	Spindle Commands	323
M05	Spindle Commands	323
M06	Tool Change	323
M07	Shower Coolant	323
M08	Coolant On	324
M09	Coolant Off	324
M10	Engage 4th Axis Brake	324
M11	Release 4th Axis Brake	324
M12	Engage 5th Axis Brake	324
M13	Release 5th Axis Brake	324
M16	Tool Change	324
M17	Unclamp APC Pallet and Open APC Door	324
M18	Clamp APC Pallet and Close Door	324
M19	Orient Spindle	325
M21	Optional User M Function with M-Fin	325
M22	Optional User M Function with M-Fin	325

**G255 Cancel Dynamic Work Offset (DWO)**

<b>Code</b>	<b>Description</b>	<b>Page</b>
M23	Optional User M Function with M-Fin	<b>325</b>
M24	Optional User M Function with M-Fin	<b>325</b>
M25	Optional User M Function with M-Fin	<b>325</b>
M26	Optional User M Function with M-Fin	<b>325</b>
M27	Optional User M Function with M-Fin	<b>325</b>
M28	Optional User M Function with M-Fin	<b>325</b>
M30	Program End and Reset	<b>326</b>
M31	Chip Conveyor Forward	<b>326</b>
M33	Chip Conveyor Stop	<b>326</b>
M34	Coolant Increment	<b>327</b>
M35	Coolant Decrement	<b>327</b>
M36	Pallet Part Ready	<b>327</b>
M39	Rotate Tool Turret	<b>328</b>
M41	Low Gear Override	<b>328</b>
M42	High Gear Override	<b>328</b>
M46	Jump if Pallet Loaded	<b>328</b>
M48	Check Validity of Current Program	<b>328</b>
M49	Set Status of Pallet	<b>329</b>
M50	Execute Pallet Change	<b>329</b>
M51	Set Optional User M-codes	<b>329</b>
M52	Set Optional User M-codes	<b>329</b>
M53	Set Optional User M-codes	<b>329</b>
M54	Set Optional User M-codes	<b>329</b>

<b>Code</b>	<b>Description</b>	<b>Page</b>
M55	Set Optional User M-codes	329
M56	Set Optional User M-codes	329
M57	Set Optional User M-codes	329
M58	Set Optional User M-codes	329
M59	Set Output Relay	329
M61	Clear Optional User M-codes	330
M62	Clear Optional User M-codes	330
M63	Clear Optional User M-codes	330
M64	Clear Optional User M-codes	330
M65	Clear Optional User M-codes	330
M66	Clear Optional User M-codes	330
M67	Clear Optional User M-codes	330
M68	Clear Optional User M-codes	330
M69	Clear Output Relay	330
M75	Set G35 or G136 Reference Point	330
M76	Control Display Inactive	330
M77	Control Display Active	330
M78	Alarm if Skip Signal Found	330
M79	Alarm if Skip Signal Not Found	331
M80	Auto Door Open	331
M81	Auto Door Close	331
M82	Tool Unclamp	331
M83	Auto Air Gun On	331

Code	Description	Page
M84	Auto Air Gun Off	331
M86	Tool Clamp	331
M88	Through-Spindle Coolant On	332
M89	Through-Spindle Coolant Off	332
M95	Sleep Mode	332
M96	Jump If No Input	333
M97	Local Sub-Program Call	333
M98	Sub-Program Call	334
M99	Sub-Program Return or Loop	334
M109	Interactive User Input	335

## Introduction to M-codes

M-codes are miscellaneous commands for the machine that do not command axis motion. The format for an M-code is the letter M followed by two numbers, for example M03.

Only one M-code is allowed per line of code. All M-codes take effect at the end of the block.

### M00 Stop Program

The M00 code is used to stop a program. It stops the axes, spindle, turns off the coolant (including Through Spindle Coolant). The next block (after the M00) will be highlighted when viewed in the program editor. Pressing **[CYCLE START]** continues program operation from the highlighted block.

### M01 Optional Program Stop

M01 works the same as M00, except the optional stop feature must be on. Press **OPTION STOP** to toggle the feature on and off.

## M02 Program End

The M02 code is used to end a program.

**NOTE:**

*The most common way of ending a program is with an M30.*

## M03 / M04 / M05 Spindle Commands

M03 turns spindle on in the clockwise (CW) direction.

M04 turns spindle on in the counter-clockwise (CCW) direction.

Spindle speed is controlled with an S address code; for example, S5000 commands a spindle speed of 5000 RPM.

If your machine has a gearbox, the spindle speed you program will determine the gear that the machine will use, unless you use M41 or M42 to override gear selection. Refer to page 328 for more information on the gear select override M-codes.

M05 Stops the spindle.

## M06 Tool Change

The M06 code is used to change tools, for example M06 T12. This will put tool 12 into the spindle. If the spindle is running, the spindle and coolant (including TSC) will be stopped by the M06 command.

## M07 Shower Coolant

This M code activates the optional shower coolant pump. The pump is turned off by M09, which also turns off standard coolant. The optional shower coolant is automatically turned off before a tool change or a pallet change, and it will automatically restart after a tool change if it was ON prior to a tool change sequence.

## M08 Coolant On / M09 Coolant Off

The M08 code will turn on the optional coolant supply and an M09 code will turn it off. Also see M34/M35 for optional P-Cool and M88/M89 for optional Through-the-spindle coolant.



**NOTE:**

*Coolant status is checked only at the start of a program, so a low coolant condition will not stop a running program.*

## M10 Engage 4th Axis Brake/M11 Release 4th Axis Brake

These codes will apply and release the brake to the optional 4th axis. The brake is normally engaged, so the M10 command is only required when an M11 has been used to release the brake.

## M12 Engage 5th Axis Brake / M13 Release 5th Axis Brake

These codes will apply and release the brake to the optional 5th axis. The brake is normally engaged, so the M12 command is only required when an M13 has been used to release the brake.

## M16 Tool Change

This M code behaves the same as M06. However M06 is the preferred method for commanding tool changes.

## M17 Unclamp APC Pallet and Open APC Door/ M18 Clamp APC Pallet and Close APC Door

This M-code is used on vertical machining centers with pallet changers. It is used as a maintenance/test function only. Pallet changes should be commanded with an M50 command only.



## M19 Orient Spindle (Optional P and R Values)

M19 adjusts the spindle to a fixed position. The spindle will only orient to the zero position without the optional M19 orient spindle feature.

The orient spindle function allows P and R address codes. For example, M19 P270 will orient the spindle to 270 degrees. The R-value allows the programmer to specify up to two decimal places; for example, M19 R123.45.

## M21-M28 Optional User M Function with M-Fin

The M codes M21 through M28 are optional for user-defined relays. Each M code activates one of the optional relays. The **[RESET]** button will stop any operation that is waiting for a relay-activated accessory to finish. Also see M51-58 and M61-68.

Some or all of the M21-M25 (M21-M22 on Toolroom, Office and Mini mills) on the I/O PCB may be used for factory-installed options. Inspect the relays for existing wires to determine which have been used. Contact your dealer for more details.

Only one relay is activated at a time. A typical operation is to command a rotary product. The sequence is: Run the machining portion of a CNC part program. Stop CNC motion and command rotary motion through the relay. Wait for a finish (stop) signal from the rotary product. Continue the CNC part program.

### M-code Relays

These outputs can be used to activate probes, auxiliary pumps or clamping devices etc. The auxiliary devices are electrically connected to the terminal strip for the individual relay. The terminal strip has a position for, Normally Open (NO), Normally Closed (NC) and Common (COM).

**F6.54:** Main I/O PCB M-code Relays: [1] Main I/O PCB M-code relays, [2] Optional M-code relay board (mounted above main I/O PCB).

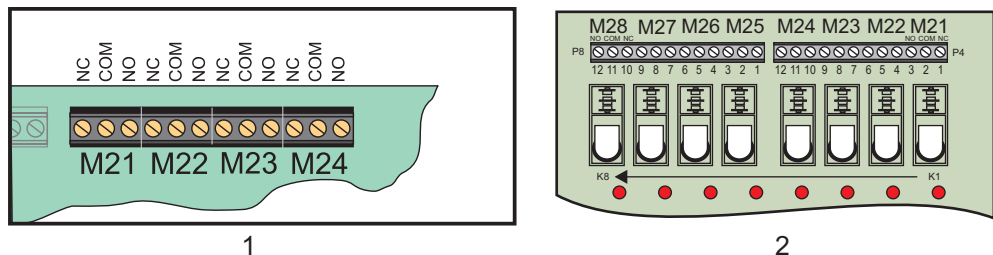

### Optional 8M-code Relays

Additional M-code relays can be purchased in banks of 8. A total of 4 banks of 8 relays are possible in the Haas system; these are numbered from 0-3. Banks 0 and 1 are internal to the main I/O PCB. Bank 1 includes the M21-25 relays at the top of the IOPCB. Bank 2 addresses the first 8M option PCB. Bank 3 addresses the second 8M option PCB.



**NOTE:**

*Bank 3 may be used for some Haas-installed options and may not be available. Contact your dealer for more details.*

Only one bank of outputs may be addressable with M-codes at a time. This is controlled by parameter 352 Relay Bank Select. Relays in the non-activated banks are only accessible with macro variables or M59/M69. Parameter 352 is shipped set to 1 as standard.

## M30 Program End and Reset

The M30 code is used to stop a program. It stops the spindle and turns off the coolant (including TSC) and the program cursor will return to the start of the program. M30 cancels tool length offsets.

## M31 Chip Conveyor Forward / M33 Chip Conveyor Stop

M31 starts the optional chip removal system (auger, multi-auger, or belt-style conveyor) in the forward direction; the direction that moves the chips out of the machine. You should run the chip conveyor intermittently, as this allows piles of larger chips to collect smaller chips and carry them out of the machine. You can set the chip conveyor duty cycle and run time with Settings 114 and 115.

The optional conveyor coolant washdown will run while the chip conveyor is on.

M33 Stops conveyor motion.

## M34 Coolant Increment / M35 Coolant Decrement

F6.55: P-Cool Spigot

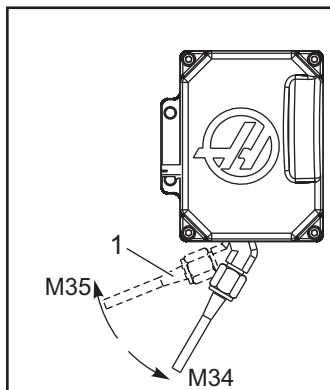

M34 moves the optional P-Cool spigot one position away from the current position (farther from home).

M35 moves the coolant spigot one position towards the home position.



**CAUTION:**

*Do not rotate the coolant spigot by hand. Serious motor damage will occur.*

## M36 Pallet Part Ready

Used on machines with pallet changers. This M code delays the pallet change until the Part Ready button is depressed. A pallet change will occur after the pallet ready button is pressed (and the doors are closed). For example:

```

Onnnnn (program number) ;
M36 (Flash "Part Ready" light, wait until the button is
pressed) ;
M01 ;
M50 (Perform pallet change after Part Ready button is pressed)
;
(Part Program) ;
M30 ;

```

## M39 Rotate Tool Turret

Tool changes should be commanded using M06. M39 is not normally required but is useful for diagnostic purposes or to recover from a tool changer crash.

The M39 code is used to rotate the side mount tool changer without performing a tool change. The desired tool pocket number (T<sub>n</sub>) must be programmed previous to the M39.

## M41 / M42 Low / High Gear Override

On machines with a transmission the M41 command is used to hold the machine in low gear and an M42 will hold the machine in high gear. Normally, the spindle speed (S<sub>nnn</sub>) determines which gear the transmission should be in.

Command M41 or M42 with the spindle speed before the spindle start command. For example:

```
S1200 M41;  
M03
```

## M46 Jump if Pallet Loaded

This M code causes the program to jump to the line number specified by the P code if the pallet specified by the Q code is currently loaded.

Example:

```
M46Qn Pnn (Jump to line nn in the current program if pallet n  
is loaded, otherwise go to the next block) ;
```

## M48 Check Validity of Current Program

This M code is used as a safeguard for pallet changing machines. Alarm 909 (910) will display if the current program (pallet) is not listed in the Pallet Schedule Table.

## M49 Set Status of Pallet

This M code sets that status of the pallet specified by the P code to the value specified by the Q code. The possible Q codes are 0-Unscheduled 1-Scheduled 2-Loaded 3-Completed 4 through 29 are user definable. The pallet status is for display purposes only. The control does not depend upon it being any particular value, but if it is 0, 1, 2 or 3, the control will update it as appropriate.

Example:

```
M49Pnn Qmm (Sets the status of pallet nn to a value of mm) ;
```

Without a P-code, this command sets the status of the currently loaded pallet.

## M50 Execute Pallet Change

Used with a P value, **[PALLET READY]** button, or the Pallet Schedule Table to perform a pallet change. Also see the Pallet Changer section.

## M51-M58 Set Optional User M-codes

The M51 through M58 codes are optional for user interfaces. They will activate one of the relays and leave it active. Use M61-M68 to turn these off. **[RESET]** turns off all of these relays.

See M21-M28 for details on the M-code relays.

## M59 Set Output Relay

This M code turns on a relay. An example of its usage is M59 Pnn, where nn is the number of the relay being turned on. An M59 command can be used to turn on any of the discrete output relays in the range from 1100 to 1155 in the same order as axes motion. When using Macros, M59 P1103 does the same thing as using the optional macro command #1103=1, except that it is processed at the end of the line of code.



**NOTE:**

*The 8 spare M functions use addresses 1140 - 1147*

## M61-M68 Clear Optional User M-codes

The M61 through M68 codes are optional for user interfaces. They will turn off one of the relays. Use M51-M58 to turn these on. [RESET] turns off all of these relays. See M21-M28 for details on the M-code relays.

## M69 Clear Output Relay

This M code turns off a relay. An example of its usage is M69 Pnn, where nn is the number of the relay being turned off. An M69 command can be used to turn off any of the output relays in the range from 1100 to 1155. When using Macros, M69 P1103 does the same thing as using the optional macro command #1103=0, except that it is processed in the same order as axes motion.

## M75 Set G35 or G136 Reference Point

This code is used to set the reference point for G35 and G136 commands. It must be used after a probing function.

## M76 Control Display Inactive / M77 Control Display Active

These codes are used to disable and enable the screen display. This M-code is useful during the running of a large complicated program as refreshing the screen takes processing power that otherwise may be necessary to command the moves of the machine.

## M78 Alarm if Skip Signal Found

This M-code is used with a probe. An M78 will generate an alarm if a programmed skip function (G31, G36 or G37) receives a signal from the probe. This is used when a skip signal is not expected, and may indicate a probe crash. This code can be placed on the same line as the skip G-code or in any block after.

## M79 Alarm if Skip Signal Not Found

This M-code is used with a probe. An `M79` will generate an alarm if a programmed skip function (`G31`, `G36`, or `G37`) did not receive a signal from the probe. This is used when the lack of the skip signal means a probe positioning error. This code can be placed on the same line as the skip G-code or in any block after.

**F6.56:** Probe Positioning Error: [1] Signal Found. [2] Signal not Found.

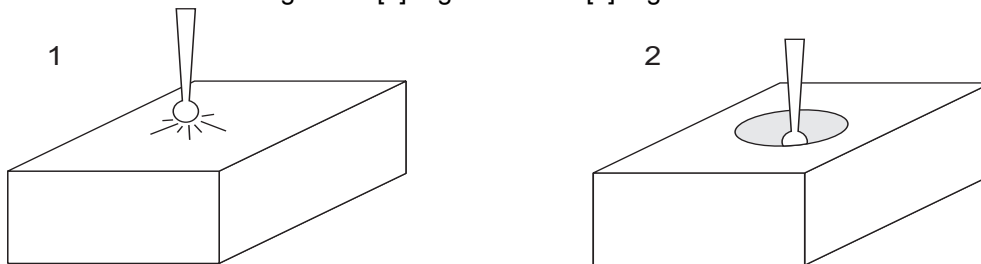

## M80 Auto Door Open / M81 Auto Door Close

`M80` opens the Auto Door and `M81` closes it. The control pendant beeps while the door is in motion.

## M82 Tool Unclamp

This code is used to release the tool from the spindle. It is used as a maintenance/test function only. Tool changes should be done using an `M06`.

## M83 Auto Air Gun On / M84 Auto Air Gun Off

An `M83` will turn the Air Gun on, and an `M84` will turn it off. Additionally, an `M83 Pnnn` (where `nnn` is in milliseconds) will turn it on for the specified time, then off automatically. The Auto Air Gun is also manually toggled on and off by pressing **[SHIFT]** followed by pressing **[COOLANT]**.

## M86 Tool Clamp

This code will clamp a tool into the spindle. It is used as a maintenance/test function only. Tool changes should be done using an `M06`.

## M88 Through-Spindle Coolant On / M89 Through-Spindle Coolant Off

The M88 code is used to turn on the through-spindle coolant (TSC) option, an M89 turns the TSC off.

Proper tooling, with a through-hole, must be in place before using the TSC system. Failure to use proper tooling will flood the spindle head with coolant and void the warranty.

### Sample Program



**NOTE:**

*The M88 command should be before the spindle speed command.*

```
T1 M6 (TSC Coolant Through Drill) ;
G90 G54 G00 X0 Y0 ;
G43 H06 Z.5 ;
M88 (Turn TSC on) ;
S4400 M3 ;
G81 Z-2.25 F44. R.03 ;
M89 G80 (Turn TSC off) ;
G91 G28 Z0 ;
M30 ;
```

## M95 Sleep Mode

Sleep mode is essentially a long dwell (pause). Sleep mode can be used when the user wants the machine to begin warming itself up so it can be ready for use upon the operator's arrival. The format of the M95 command is:

```
M95 (hh:mm)
```

The comment immediately following M95 must contain the hours and minutes that the machine is to sleep.

For example, if the current time were 6 p.m. and the user wants the machine to sleep until 6:30 a.m. the next day, the following command would be used:

```
M95 (12:30) ;
```

The line(s) following M95 should be axis moves and spindle warm-up commands.



## M96 Jump If No Input

**P** - Program block to go to when conditional test is met

**Q** - Discrete input variable to test (0 to 63)

This code is used to test a discrete input for 0 (off) status. This is useful for checking the status of automatic work holding or other accessories that will generate a signal for the control. The **Q** value must be in the range 0 to 63, which corresponds to the inputs found on the diagnostic display (The upper left input is 0 and the lower right is input 63. When this program block is executed and the input signal specified by **Q** has a value of 0, the program block **Pnnnn** is performed (the **Nnnnn** that matches the **Pnnnn** line must be in the same program).

**M96 Example:**

```
N05 M96 P10 Q8 (Test input #8, Door Switch, until closed) ;
N10 (Start of program loop) ;
... ;
... (Program that machines part) ;
... ;
N85 M21 (Execute an external user function) ;
N90 M96 P10 Q27 (Loop to N10 if spare input [#27] is 0) ;
N95 M30 (If spare input is 1 then end program) ;
```

## M97 Local Sub-Program Call

This code is used to call a subroutine referenced by a line number (**N**) within the same program. A code is required and must match a line number within the same program. This is useful for simple subroutines within a program; does not require a separate program. The subroutine must end with an **M99**. An **Lnn** code in the **M97** block will repeat the subroutine call that **nn** times.



**NOTE:**

*The subroutine is within the body of the main program, placed after the M30.*

**M97 Example:**

```
%
O00001 ;
M97 P100 L4 (CALLS N100 SUBROUTINE) ;
M30 ;
N100 (SUBROUTINE) ; ;
M00 ;
M99 (RETURNS TO MAIN PROGRAM) ;
```

⌘

### M98 Sub-Program Call

This code is used to call a sub-program, the format is `M98 Pnnnn` (`Pnnnn` is the number of the program being called). The sub-program must be in the program list, and it must contain an `M99` to return to the main program. An `Lnn` count can be put on the line containing `M98` and causes the sub-program to be called `nn` times before continuing to the next block.

When an `M98` sub-program is called, the control looks for the sub-program on the active drive, and then in memory if the sub-program cannot be located. The active drive may be memory, USB drive, or hard drive. An alarm occurs if the control does not find the sub-program on either the active drive or in memory.



**NOTE:**

*The subprogram is a separate program (000100) from the main program (000002).*

```
⌘
000002 ;
M98 P100 L4 (CALLS 000100 SUB 4 TIMES) ;
M30 ;
⌘
⌘
000100 (SUBPROGRAM) ;
M00 ;
M99 (RETURN TO MAIN PROGRAM) ;
⌘
```

### M99 Sub-Program Return or Loop

This code has three main uses:

- An `M99` is used at the end of a subprogram, local subprogram, or macro to return back to the main program.
- An `M99 Pnn` will jump the program to the corresponding `Nnn` in the program.
- An `M99` in the main program will cause the program to loop back to the beginning and execute until **[RESET]** is pressed.



**NOTE:**

*Fanuc behavior is simulated by using the following code:*

	Haas	Fanuc
calling program:	O0001 ;	O0001 ;
	...	...
	N50 M98 P2 ;	N50 M98 P2 ;
	N51 M99 P100 ;	...
	...	N100 (continue here) ;
	N100 (continue here) ;	...
	...	M30 ;
	M30 ;	
subroutine:	O0002 ;	O0002 ;
	M99 ;	M99 P100 ;

**M99 With Macros** - If the machine is equipped with the optional macros, use a global variable and specify a block to jump to by adding #nnn=dddd in the sub-program and then using M99 P#nnn after the sub-program call.

## M109 Interactive User Input

This M code allows a G-code program to place a short prompt (message) on the screen. A macro variable in the range 500 through 599 must be specified by a P code. The program can check for any character that can be entered from the keyboard by comparing with the decimal equivalent of the ASCII character (G47, Text Engraving, has a list of ASCII characters).

The following sample program will ask the user a Yes or No question, then wait for either a Y or an N to be entered. All other characters will be ignored.

```
N1 #501= 0. (Clear the variable) ;
N5 M109 P501(Sleep 1 min?) ;
IF [ #501 EQ 0. ] GOTO5 (Wait for a key) ;
IF [ #501 EQ 89. ] GOTO10 (Y) ;
IF [ #501 EQ 78. ] GOTO20 (N) ;
GOTO1(Keep checking) ;
```

```
N10(A Y was entered) ;
M95 (00:01) ;
GOTO30 ;
N20(An N was entered) ;
G04 P1.(Do nothing for 1 second) ;
N30(Stop) ;
M30 ;
```

The following sample program will ask the user to select a number, then wait for a 1, 2, 3, 4 or a 5 to be entered; all other characters will be ignored.

```
O01234 (M109 Program) ;
N1 #501= 0 (Clear Variable #501) ;
(Variable #501 will be checked) ;
(Operator enters one of the following selections) ;
N5 M109 P501 (1,2,3,4,5) ;
IF [ #501 EQ 0 ] GOTO5 ;
(Wait for keyboard entry loop until entry) ;
(Decimal equivalent from 49-53 represent 1-5) ;
IF [ #501 EQ 49 ] GOTO10 (1 was entered go to N10) ;
IF [ #501 EQ 50 ] GOTO20 (2 was entered go to N20) ;
IF [ #501 EQ 51 ] GOTO30 (3 was entered go to N30) ;
IF [ #501 EQ 52 ] GOTO40 (4 was entered go to N40) ;
IF [ #501 EQ 53 ] GOTO50 (5 was entered go to N50) ;
GOTO1 (Keep checking for user input loop until found) ;
N10 ;
(If 1 was entered run this sub-routine) ;
(Go to sleep for 10 minutes) ;
#3006= 25 (Cycle start sleeps for 10 minutes) ;
M95 (00:10) ;
GOTO100 ;
N20 ;
(If 2 was entered run this sub routine) ;
(Programmed message) ;
#3006= 25 (Programmed message cycle start) ;
GOTO100 ;
N30 ;
(If 3 was entered run this sub routine) ;
(Run sub program 20) ;
#3006= 25 (Cycle start program 20 will run) ;
G65 P20 (Call sub-program 20) ;
GOTO100 ;
N40 ;
(If 4 was entered run this sub routine) ;
(Run sub program 22) ;
#3006= 25 (Cycle start program 22 will be run) ;
M98 P22 (Call sub program 22) ;
GOTO100 ;
```

```

N50 ;
  (If 5 was entered run this sub-routine) ;
  (Programmed message) ;
#3006= 25 (Reset or cycle start will turn power off) ;
#1106= 1 ;
N100 ;
M30 ;

```

## 6.4 Settings

These Setting descriptions are valid for the Haas Mill and are listed in numerical order.

### T6.2: Settings List

Setting	Description	Setting	Description
1	Auto Power Off Timer	2	Power Off at M30
4	Graphics Rapid Path	5	Graphics Drill Point
6	Front Panel Lock	7	Parameter Lock
8	Prog Memory Lock	9	Dimensioning
10	Limit Rapid at 50%	11	Baud Rate Select
12	Parity Select	13	Stop Bit
14	Synchronization	15	H & T Code Agreement
16	Dry Run Lock Out	17	Opt Stop Lock Out
18	Block Delete Lock Out	19	Feedrate Override Lock
20	Spindle Override Lock	21	Rapid Override Lock
22	Can Cycle Delta Z	23	9xxx Progs Edit Lock
24	Leader To Punch	25	EOB Pattern
26	Serial Number	27	G76/G77 Shift Dir.
28	Can Cycle Act w/o X/Y	29	G91 Non-modal
30	4th Axis Enable	31	Reset Program Pointer

<b>Setting</b>	<b>Description</b>	<b>Setting</b>	<b>Description</b>
32	Coolant Override	33	Coordinate System
34	4th Axis Diameter	35	G60 Offset
36	Program Restart	37	RS-232 Data Bits
39	Beep @ M00, M01, M02, M30	40	Tool Offset Measure
41	Add Spaces RS-232 Out	42	M00 After Tool Change
43	Cutter Comp Type	44	Min F in Radius CC %
45, 46, 47, 48	Mirror Image X, Y, Z, A-Axis	49	Skip Same Tool Change
52	G83 Retract Above R	53	Jog w/o Zero Return
54	AuX Axis Baud Rate	55	Enable DNC from MDI
56	M30 Restore Default G	57	Exact Stop Canned X-Y
58	Cutter Compensation	59, 60, 61, 62	Probe Offset X+, X, Z+, Z
63	Tool Probe Width	64	Tool Offset Measure Uses
65	Graph Scale (Height)	66	Graphics X Offset
67	Graphics Y Offset	68	Graphics Z Offset
69	DPRNT Leading Spaces	70	DPRNT Open/CLOS DCode
71	Default G51 Scaling	72	Default G68 Rotation
73	G68 Incremental Angle	74	9xxx Progs Trace
75	9xxxx Progs Singls BLK	76	Tool Release Lock Out
77	Scale Integer F	78	5th axis Enable
79	5th-axis Diameter	80	Mirror Image B-Axis
81	Tool At Power Up	82	Language
83	M30/Resets Overrides	84	Tool Overload Action
85	Maximum Corner Rounding	86	M39 Lockout

Setting	Description	Setting	Description
87	M06 Resets Override	88	Reset Resets Overrides
90	Max Tools To Display	100	Screen Saver Delay
101	Feed Override- > Rapid	103	CYC START/FH Same Key
104	Jog Handle to SNGL BLK	108	Quick Rotary G28
109	Warm-Up Time in MIN.	110, 111, 112	Warmup X, Y, Z Distance
114, 115	Conveyor Cycle Time, On-Time (minutes)	116	Pivot Length
117	G143 Global Offset	118	M99 Bumps M30 CNTRS
119	Offset Lock	120	Macro Var Lock
130	Tap Retract Speed	131	Auto Door
133	REPT Rigid Tap	142	Offset Chng Tolerance
143	Machine Data Collect	144	Feed Override->Spindles
155	Load Pocket Tables	156	Save Offset with PROG
157	Offset Format Type	158,159,160	XYZ Screw Thermal COMP%
162	Default To Float	163	Disable .1 Jog Rate
164	Rotary Increment	167-186	Periodic Maintenance
187	Machine Data Echo	188, 189, 190	G51 X, Y, Z SCALE
191	Default Smoothness	196	Conveyor Shutdown
197	Coolant Shutdown	198	Background Color
199	Display Off Timer (Minutes)	201	Show Only Work and Tool Offsets In Use
216	Servo and Hydraulic Shutoff	238	High Intensity Light Timer (minutes)
239	Worklight Off Timer (minutes)	240	Tool Life Warning

<b>Setting</b>	<b>Description</b>	<b>Setting</b>	<b>Description</b>
242	Air Water Purge Interval (minutes)	243	Air Water Purge On-Time (seconds)
244	Master Gage Tool Length (inches)	245	Hazardous Vibration Sensitivity
247	Simultaneous XYZ Motion Tool Change	249	Enable Haas Startup Screen
900	CNC Network Name	901	Obtain Address Automatically
902	IP Address	903	Subnet Mask
904	Default Gateway	905	DNS Server
906	Domain/Workgroup Name	907	Remote Server Name
908	Remote Share Path	909	User Name
910	Password	911	Access to CNC Share (Off, Read, Full)
912	Floppy Tab Enabled	913	Hard Drive Tab Enabled
914	USB Tab Enabled	915	Net Share
916	Second USB Tab Enabled		

## **Introduction to Settings**

The setting pages contain values that control machine operation and that the user may need to change. Most settings can be changed by the operator. They are preceded by a short description on the left and the value on the right.

Settings are presented in tabbed menus. For information on navigating tabbed menus in the Haas control, refer to page **67**. The on-screen settings are organized into pages of functionally similar groupings. The following list is separated into page groups with the page title as the heading.

Use the vertical cursor keys to move to the desired setting. You can also quickly access a setting by typing the setting number and pressing the Down Cursor.



Depending on the setting, it may be changed by entering a new number or, if the setting has specific values, press the horizontal cursor keys to display the choices. Press **[ENTER]** to enter or change the value. The message near the top of the screen displays how to change the selected setting.

## 1 - Auto Power Off Timer

This setting is used to automatically power-down the machine after a period of idle time. The value entered in this setting is the number of minutes the machine will remain idle until it is powered down. The machine will not be powered down while a program is running, and the time (number of minutes) will start back at zero anytime a button is pressed or the **[HANDLE JOG]** control is used. The auto-off sequence gives the operator a 15-second warning before power down, at which time pressing any button will stop the power down.

## 2 - Power Off at M30

Powers down the machine at the end of a program (M30) if this setting is set to **ON**. The machine will give the operator a 15-second warning once an M30 is reached. Pressing any button will interrupt the sequence.

## 4 - Graphics Rapid Path

This setting changes the way a program is viewed in the Graphics mode. When it is **OFF**, rapid, non-cutting tool motions do not leave a path. When it is **ON**, rapid tool motions leave a dashed line on the screen.

**F6.57:** Setting 4, Graphics Rapid Path Tool Lines Shown When **ON**

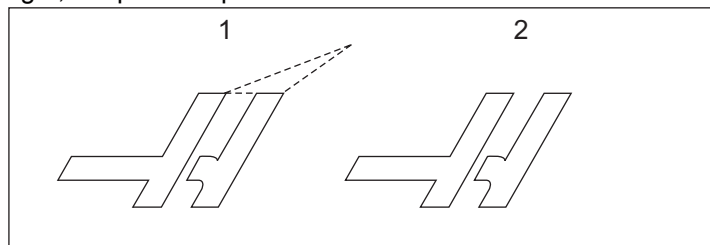

## 5 - Graphics Drill Point

This setting changes the way a program is viewed in Graphics mode. When it is **ON**, motion in the Z-Axis will leave an **x** mark on the screen. When it is **OFF**, no additional marks are shown on the graphics display.

**F6.58:** Setting 5, Drill Point X Mark Displays When **ON**

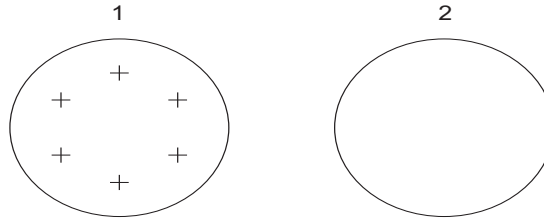

## 6 - Front Panel Lock

When set to **ON**, this setting disables the Spindle **[CW ]/[ CCW ]** keys and **[ATC FWD] / [ATC REV]** keys.

## 7 - Parameter Lock

Turning this setting **ON** will stop the parameters from being changed, except for parameters 81-100.



**NOTE:**

*Each time the control is powered up, this setting is set to **ON**.*

## 8 - Prog Memory Lock

This setting locks out the memory editing functions (**[ALTER]**, **[INSERT]**, etc.) when it is set to **ON**.

# 9 - Dimensioning

This setting selects between inch and metric mode. When it is set to **INCH**, the programmed units for X, Y, and Z are inches, to 0.0001". When it is set to **MM**, programmed units are millimeters, to 0.001mm. All offset values are converted when this setting is changed from inches to metric, or vice versa. However, changing this setting will not automatically translate a program stored in memory; the programmed axis values must be changed for the new units.

When set to **INCH**, the default G code is G20, when set to **MM**, the default G code is G21.

**F6.59:** Setting 9, Changes Inch to Metric Mode

	INCH	METRIC
<b>Feed</b>	inches/min.	mm/min.
<b>Max Travel</b>	Varies by axis and model	
<b>Min. Programmable Dimension</b>	.0001	.001
<b>Feed Range</b>	.0001 to 300.000 in/min.	.001 to 1000.000

Axis Jog Keys		
<b>.0001 Key</b>	.0001 in/jog click	.001 mm/jog click
<b>.001</b>	.001 in/jog click	.01 mm/jog click
<b>.01</b>	.01 in/jog click	.1 mm/jog click
<b>.1 Key</b>	.1 in/jog click	1 mm/jog click

# 10 - Limit Rapid at 50%

Turning this setting **ON** will limit the machine to 50% of its fastest non-cutting axis motion (rapids). This means, if the machine can position the axes at 700 inches per minute (ipm), it will be limited to 350 ipm when this setting is **ON**. The control will display a 50% rapid override message, when this setting is **ON**. When it is **OFF**, the highest rapid speed of 100% is available.

# 11 - Baud Rate Select

This setting allows the operator to change the rate at which data is transferred to/from the serial port (RS-232). This applies to the upload/download of programs, etc., and to DNC functions. This setting must match the transfer rate from the personal computer.

## 12 - Parity Select

This setting defines parity for the serial port (RS-232). When set to **NONE**, no parity bit is added to the serial data. When set to **ZERO**, a 0 bit is added. **EVEN** and **ODD** work like normal parity functions. Make sure the system needs are understood, for example, **XMODEM** must use 8 data bits and no parity (set to **NONE**). This setting must match the personal computer.

## 13 - Stop Bit

This setting designates the number of stop bits for the serial port (RS-232). It can be 1 or 2. This setting must match the personal computer.

## 14 - Synchronization

This changes the synchronization protocol between sender and receiver for the serial port (RS-232). This setting must match the personal computer. When set to **RTS/CTS**, the signal wires in the serial data cable are used to tell the sender to temporarily stop sending data while the receiver catches up. When set to **XON/XOFF**, the most common setting, ASCII character codes are used by the receiver to tell the sender to temporarily stop.

The selection **DC CODES** is like **XON/XOFF**, except that paper tape punch or reader Start/Stop codes are sent. **XMODEM** is a receiver-driven communications protocol that sends data in blocks of 128 bytes. **XMODEM** has added reliability as each block is checked for integrity. **XMODEM** must use 8 data bits and no parity.

## 15 - H & T Code Agreement

Turning this setting **ON** has the machine check to ensure that the **H** offset code matches the tool in the spindle. This check can help to prevent crashes.



**NOTE:**

*This setting will not generate an alarm with an **H00**. **H00** is used to cancel the tool length offset.*

## 16 - Dry Run Lock Out

The Dry Run feature will not be available when this setting is turned **ON**.

## 17 - Opt Stop Lock Out

The Optional Stop feature will not be available when this setting is **ON**.

## 18 - Block Delete Lock Out

The Block Delete feature will not be available when this setting is **ON**.

## 19 - Feedrate Override Lock

The feedrate override buttons will be disabled when this setting is turned **ON**.

## 20 - Spindle Override Lock

The spindle speed override buttons will be disabled when this setting is turned **ON**.

## 21 - Rapid Override Lock

The axis rapid override buttons are disabled when this setting is turned **ON**.

## 22 - Can Cycle Delta Z

This setting specifies the distance the Z-Axis is retracted to clear chips during a G73 canned cycle. The range is 0.0000 to 29.9999 inches (0-760 mm).

## 23 - 9xxx Progs Edit Lock

Turning this setting **ON** prevents the 9000 series of programs from being viewed in memory, edited, or deleted. 9000 series programs cannot be uploaded or downloaded while this setting is **ON**.



**NOTE:**

*9000 series programs are usually macro programs.*

## 24 - Leader To Punch

This setting is used to control the leader (the blank tape at the beginning of a program) sent to a paper tape punch device connected to the RS-232 port.

## 25 - EOB Pattern

This setting controls the **[EOB]** (End of Block) pattern when data is sent and received to/from the serial port (RS-232). The choices are **CR LF**, **LF ONLY**, **LF CR**, and **CR ONLY**.

## 26 - Serial Number

This is the serial number of the machine. It cannot be changed.

## 27 - G76/G77 Shift Dir.

This setting controls the direction the tool is shifted (moved) to clear a boring tool during a *G76* or *G77* canned cycle. Selections are **X+**, **X-**, **Y+**, or **Y-**. For more information on how this setting works see the *G76* and *G77* cycle in the G code section.

**F6.60:** Setting 27, Direction the Tool is Shifted to Clear Boring Tool: [1] Part, [2] Bored hole.

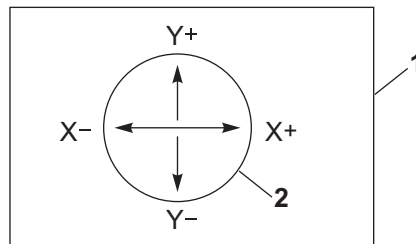

## 28 - Can Cycle Act w/o X/Y

This is an **ON/OFF** setting. The preferred setting is **ON**.

When it is **OFF**, the initial canned cycle definition block requires an **X** or **Y** code for the canned cycle to be executed.

When it is **ON**, the initial canned cycle definition block will cause one cycle to be executed even when there is no **X** or **Y** code in the block.

**NOTE:**

*Note that when an L0 is in that block, it will not execute the canned cycle on the definition line.*

## 29 - G91 Non-modal

Turning this setting **ON** uses the G91 command only in the program block it is in (non-modal). When it is **OFF**, and a G91 is commanded, the machine will use incremental moves for all axis positions.

**NOTE:**

*This setting must be OFF for G47 engraving cycles.*

## 30 - 4th Axis Enable

This setting initializes the control for a specific 4th axis. For details on changing this Setting, see the 4th and 5th Axis Programming section of this manual. When this setting is **OFF**, the fourth axis is disabled; no commands can be sent to that axis. See Setting 78 for 5th axis.

**NOTE:**

*Selections: USER1 and USER2 can be used to set-up a unique rotary table.*

## 31 - Reset Program Pointer

When this setting is **OFF**, **[RESET]** will not change the position of the program pointer. When it is **ON**, pressing **[RESET]** moves the program pointer to the beginning of the program.

## 32 - Coolant Override

This setting controls how the coolant pump operates. The **NORMAL** selection allows the operator to turn the pump on and off manually or with M-codes. The **OFF** selection gives the message *FUNCTION LOCKED* if an attempt is made to turn the coolant on manually or from a program. The **IGNORE** selection will ignore all programmed coolant commands, but the pump can be turned on manually.

## 33 - Coordinate System

This setting changes the way the Haas control recognizes the work offset system when a G52 or G92 is programmed. It can be set to **FANUC**, **HAAS**, or **YASNAC**.

Set to **YASNAC**

G52 becomes another work offset; like G55.

Set to **FANUC** with G52:

Any values in the G52 register are added to all work offsets (global coordinate shift). This G52 value can be entered either manually or through a program. When **FANUC** is selected, pressing [**RESET**], commanding an M30, or machine power down will clear out the value in G52.

Set to **HAAS** with G52:

Any values in the G52 register are added to all work offsets. This G52 value can be entered either manually or through a program. The G52 coordinate shift value is set to zero (zeroed) by manually entering zero, or by programming it with G52 X0, Y0, and/or Z0.

Set to **YASNAC** with G92:

Selecting **YASNAC** and programming a G92 X0 Y0, the control enters the current machine location as a new zero point (Work Zero Offset), and that location is entered into and viewed in the G52 list.

Set to **FANUC** or **HAAS** with G92:

Selecting **FANUC** or **HAAS** with a G92, works like the **YASNAC** setting, except that the new Work Zero location value is loaded as a new G92. This new value in the G92 list is used, in addition to, the presently recognized work offset to define the new work zero location.

## 34 - 4th Axis Diameter

This is used to set the diameter of the A Axis (0.0000 to 50.0000 inches), which the control uses to determine the angular feedrate. The feedrate in a program is always inches or millimeters per minute (G94); therefore, the control must know the diameter of the part being machined in the A Axis in order to compute angular feedrate. Refer to Setting 79 on page (358) for information on the 5th axis diameter setting.

## 35 - G60 Offset

This is a numeric entry in the range 0.0000 to 0.9999 inches. It is used to specify the distance an axis will travel past the target point prior to reversing. Also see G60.



## 36 - Program Restart

When this setting is **ON**, restarting a program from a point other than the beginning will direct the control to scan the entire program to make sure that the tools, offsets, G and M codes, and axis positions are set correctly before the program starts at the block where the cursor is positioned. The following M codes are processed when Setting 36 is enabled:

**NOTE:**

*The machine will go to the position and change to the tool specified in the block before the cursor position first. For example, if the cursor is on a tool change block in the program, the machine changes to the tool loaded before that block, then it changes to the tool specified in the block at the cursor location.*

M08 Coolant On

M09 Coolant Off

M41 Low Gear

M42 High Gear

M51-M58 Set User M

M61-M68 Clear User M

When it is **OFF** the program will start without checking the conditions of the machine. Having this setting **OFF** may save time when running a proven program.

## 37 - RS-232 Data Bits

This setting is used to change the number of data bits for the serial port (RS-232). This setting must match the transfer rate from the personal computer. Normally 7 data bits should be used but some computers require 8. XMODEM must use 8 data bits and no parity.

## 39 - Beep @ M00, M01, M02, M30

Turning this setting **ON** causes the keyboard beeper to sound when an M00, M01 (with Optional Stop active), M02 or an M30 is found. The beeper continues until a button is pressed.

## 40 - Tool Offset Measure

This setting selects how tool size is specified for cutter compensation. Set to either **RADIUS** or **DIAMETER**.

## 41 - Add Spaces RS-232 Out

When this setting is **ON**, spaces are added between address codes when a program is sent out via the RS-232 serial port. This can make a program much easier to read/edit on a personal computer (PC). When it is set to **OFF**, programs sent out the serial port have no spaces and are more difficult to read.

## 42 - M00 After Tool Change

Turning this setting **ON** will stop the program after a tool change and a message will be displayed stating this. **[CYCLE START]** must be pressed to continue the program.

## 43 - Cutter Comp Type

This controls how the first stroke of a compensated cut begins and the way the tool is cleared from the part. The selections can be **A** or **B**; see the Cutter Compensation section.

## 44 - Min F in Radius CC %

Minimum feedrate in radius cutter compensation percent setting affects the feed rate when cutter compensation moves the tool towards the inside of a circular cut. This type of cut will slow down to maintain a constant surface feed rate. This setting specifies the slowest feed rate as a percentage of the programmed feed rate (range 1-100).

## 45, 46, 47, 48 - Mirror Image X, Y, Z, A-Axis

When one or more of these settings is **ON**, axis motion is mirrored (reversed) around the work zero point. See also G101, Enable Mirror Image.

**F6.61:** Setting 45, 46, 47, and 48, Axis Motion Mirror Image

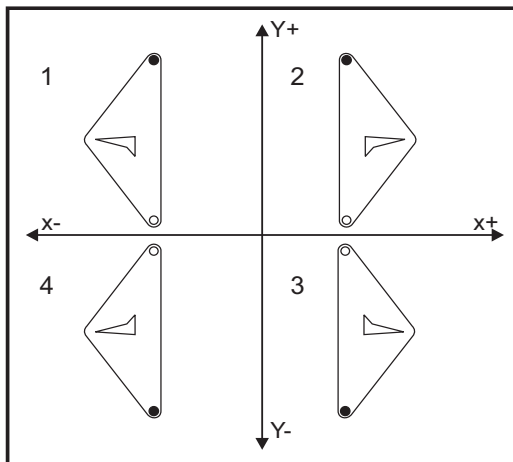

## 49 - Skip Same Tool Change

In a program, the same tool may be called in the next section of a program or a subroutine. The control will do two tool changes and finish with the same tool in the spindle. Turning this setting **ON** skips same-tool changes; a tool change only occurs if a different tool is placed in the spindle.



**NOTE:**

*This setting only affects machines with carousel (umbrella) tool changers.*

## 52 - G83 Retract Above R

Range is 0.0000 to 30.0000 inches (0-761mm). This setting changes the way G83 (peck drilling cycle) behaves. Most programmers set the reference (R) plane well above the cut to ensure that the chip clearing motion actually allows the chips to get out of the hole. However this wastes time as the machine will drill through this empty distance. If Setting 52 is set to the distance required to clear chips, the R plane can be set much closer to the part being drilled.

**F6.62:** Setting 52, Drill Retract Distance: [1] Setting 52, [2] Start Position, [3] Retract Distance Set by Setting 52, [4] R Plane

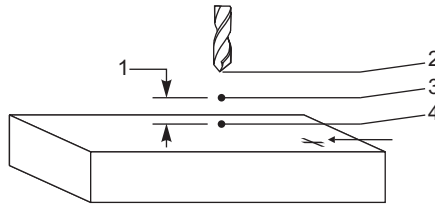

## 53 - Jog w/o Zero Return

Turning this setting **ON** allows the axes to be jogged without zero returning the machine (finding machine home). This is a dangerous condition as the axis can be run into the mechanical stops and possibly damage the machine. When the control is powered up, this setting automatically returns to **OFF**.

## 55 - Enable DNC from MDI

Turning this setting **ON** will make the DNC feature available. DNC is selected, in the control by pressing **[MDI/DNC]** twice.

The DNC Direct Numeric Control feature is not available when Setting 55 is set to **OFF**.

## 56 - M30 Restore Default G

When this setting is **ON**, ending a program with M30 or pressing **[RESET]** returns all modal G codes to their defaults.

## 57 - Exact Stop Canned X-Y

When this setting is **OFF**, the axes may not get to the programmed X, Y position before the Z-Axis starts moving. This may cause problems with fixtures, fine part details or workpiece edges.

Turning this setting **ON** ensures the mill will reach the programmed X,Y position before the Z-Axis moves.

## 58 - Cutter Compensation

This setting selects the type of cutter compensation used (FANUC or YASNAC). See the Cutter Compensation section.

## 59, 60, 61, 62 - Probe Offset X+, X-, Y+, Y-

These settings are used to define the displacement and size of the spindle probe. They specify the travel distance and direction from where the probe is triggered to where the actual sensed surface is located. These settings are used by G31, G36, G136, and M75 codes. The values entered for each setting can be either positive or negative numbers, equal to the radius of the probe stylus tip.

You can use macros to access these settings; for more information, refer to the Macro section of this manual (starting on page 178).



**NOTE:**

*These settings are not used with the Renishaw WIPS option.*

## 63 - Tool Probe Width

This setting is used to specify the width of the probe used to test tool diameter. This setting only applies to the probing option; it is used by G35. This value is equal to the diameter of the tool probe stylus.

## 64 - Tool Offset Measure Uses Work

This setting changes the way [TOOL OFFSET MEASURE] works. When this is **ON**, the entered tool offset is the measured tool offset plus the work coordinate offset (Z-Axis). When it is **OFF**, the tool offset equals the Z machine position.

## 65 - Graph Scale (Height)

This setting specifies the height of the work area that is displayed on the Graphics mode screen. The default value for this setting is the maximum height, which is the entire machine work area. Using the following formula can set a specific scale:

$$\text{Total Y travel} = \text{Parameter } 20 / \text{Parameter } 19$$

$$\text{Scale} = \text{Total Y travel} / \text{Setting } 65$$

## 66 - Graphics X Offset

This setting locates the right side of the scaling window relative to the machine X zero position (see the Graphics section). Its default is zero.

## 67 - Graphics Y Offset

This setting locates the top of the zoom window relative to the machine Y zero position (see the Graphics section). Its default is zero.

**F6.63:** Setting 57, Graphics Y Offset: [1] Setting 66 and 67 set to 0, [2] Setting 66 and 67 set to 2.0

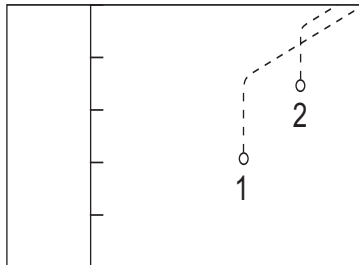

## 68 - Graphics Z Offset

Reserved for future use.

## 69 - DPRNT Leading Spaces

This is an **ON/OFF** setting. When set to **OFF**, the control will not use leading spaces generated by a macro DPRNT format statement. Conversely, when set to **ON**, the control will use leading spaces. The following example illustrates control behavior when this setting is **OFF** or **ON**.

```
#1 = 3.0 ;
G0 G90 X#1 ;
DPRNT[X#1[44]] ;
```

OUTPUT

OFF	ON
X3.0000	X 3.0000

Notice the space between the X and the 3 when the setting is **ON**. Information can be easier to read when this setting is **ON**.

## 70 - DPRNT Open/CLOS DCode

This setting controls whether the **POPEN** and **PCLOS** statements in macros send DC control codes to the serial port. When the setting is **ON**, these statements will send DC control codes. When it is **OFF**, the control codes are suppressed. The default value is **ON**.

## 71 Default G51 Scaling

This specifies the scaling for a **G51** (See G-code Section, **G51**) command when the **P** address is not used. The default is 1.000 (Range 0.001 to 8380.000).

## 72 Default G68 Rotation

This specifies the rotation, in degrees, for a **G68** command when the **R** address is not used. It must be in the range 0.0000 to 360.0000°.

## 73 G68 Incremental Angle

This setting allows the G68 rotation angle to be changed for each commanded G68. When this switch is **ON** and a G68 command is executed in the Incremental mode (G91), then the value specified in the R address is added to the previous rotation angle. For example an R value of 10 will cause the feature rotation to be 10 degrees the first time commanded, 20 degrees the next time, etc.

**NOTE:**

*This setting must be OFF when you command an engraving cycle (G47).*

## 74 - 9xxx Progs Trace

This setting, along with Setting 75, is useful for debugging CNC programs. When Setting 74 is **ON**, the control will display the code in the macro programs (O9xxxx). When the setting is **OFF**, the control will not display the 9000 series code.

## 75 - 9xxxx Progs Singls BLK

When Setting 75 is **ON** and the control is operating in Single Block mode, then the control will stop at each block of code in a macro program (O9xxxx) and wait for the operator to press **[CYCLE START]**. When Setting 75 is **OFF** the macro program is run continuously, the control will not pause at each block, even if Single Block is **ON**. The default setting is **ON**.

When Setting 74 and Setting 75 are both **ON**, the control acts normally. That is, all blocks executed are highlighted and displayed, and when in Single Block mode there is a pause before each block is executed.

When Setting 74 and Setting 75 are both **OFF**, the control will execute 9000 series programs without displaying the program code. If the control is in Single Block mode, no single-block pause will occur during the running of the 9000 series program.

When Setting 75 is **ON** and Setting 74 is **OFF**, then 9000 series programs are displayed as they are executed.

## 76 - Tool Release Lock Out

When this setting is **ON**, the **[TOOL RELEASE]** key on the keyboard is disabled.



## 77 - Scale Integer F

This setting allows the operator to select how the control interprets an F value (feedrate) that does not contain a decimal point. (It is recommended that you always use a decimal point.) This setting helps operators run programs developed on a control other than Haas. For example F12 becomes:

- 0.0012 units/minute with Setting 77 **OFF**
- 12.0 units/minute with Setting 77 **ON**

There are 5 feedrate settings. This chart shows the effect of each setting on a given F10 address.

INCH		MILLIMETER	
DEFAULT	(.0001)	DEFAULT	(.001)
INTEGER	F1 = F1	INTEGER	F1 = F1
.1	F10 = F1.	.1	F10 = F1.
.01	F10 = F.1	.01	F10 = F.1
.001	F10 = F.01	.001	F10 = F.01
.0001	F10 = F.001	.0001	F10 = F.001

## 78 - 5th Axis Enable

When this setting is **OFF** the fifth axis is disabled and no commands can be sent to that axis. See Setting 30 for 4th axis.



**NOTE:**

*There are two selections **USER1** and **USER2** that can be used to set-up a unique rotary table.*

## 79 - 5th-Axis Diameter

This is used to set the diameter of the 5th axis (0.0 to 50 inches), which the control will use to determine the angular feedrate. The feedrate in a program is always inches or millimeters per minute; therefore, the control must know the diameter of the part being machined in the 5th-axis in order to compute angular feedrate. Refer to Setting 34 (page 348) for more information on the 4th axis diameter setting.

## 80 - Mirror Image B-Axis

This is an **ON/OFF** setting. When it is **OFF**, axis motions occur normally. When it is **ON**, B Axis motion may be mirrored (or reversed) around the work zero point. Also see Settings 45-48 and G101.

## 81 - Tool At Power Up

When **[POWER UP/RESTART]** is pressed, the control changes to the tool specified in this setting. If zero (0) is specified, no tool change occurs at power up. The default setting is 1.

Setting 81, will cause one of the following actions to occur after pressing **[POWER UP/RESTART]**:

- If Setting 81 is set to zero, the carousel will be rotated to pocket #1. No tool change is performed.
- If Setting 81 contains the tool #1, and the tool currently in the spindle is tool #1, and **[ZERO RETURN]** then **[ALL]** are pressed, the carousel will remain at the same pocket and no tool change will be performed.
- If Setting 81 contains the tool number of a tool not currently in the spindle, the carousel will be rotated to pocket #1 and then to the pocket containing the tool specified by Setting 81. A tool change will be performed to change the specified tool into the spindle.

## 82 - Language

Languages other than English are available in the Haas control. To change to another language, choose a language with the **[LEFT]** and **[RIGHT]** cursor arrows, then press **[ENTER]**.

## 83 - M30/Resets Overrides

When this setting is **ON**, an **M30** restores any overrides (feedrate, spindle, rapid) to their default values (100%).

## 84 - Tool Overload Action

This setting causes the specified action (**ALARM**, **FEEDHOLD**, **BEEP**, **AUTOFEED**) to occur anytime a tool becomes overloaded (see the Tooling section).

Choosing **ALARM** will cause the machine to stop when the tool is overloaded.

When set to **FEEDHOLD**, the message *Tool Overload* will be displayed and the machine will stop in a feedhold situation when this condition occurs. Pressing any key will clear the message.

Selecting **BEEP** will cause an audible noise (beep) from the control when the tool is overloaded.

When set to **AUTOFEED**, the control automatically limits the feedrate based on the tool load.



### NOTE:

*When tapping (rigid or floating), the feed and spindle overrides will be locked out, so the **AUTOFEED** feature will be ineffective (the control will appear to respond to the override buttons, by displaying the override messages). The **AUTOFEED** feature should not be used when thread milling or auto reversing tapping heads, as it may cause unpredictable results or even a crash.*

The last commanded feedrate would be restored at the end of the program execution, or when the operator presses **[RESET]** or turns **OFF** the Autofeed feature. The operator may use the keyboard **[FEEDRATE OVERRIDE]** buttons while the Autofeed feature is selected. These buttons will be recognized by the Autofeed feature as the new commanded feedrate as long as the tool load limit is not exceeded. However, if the tool load limit has already been exceeded, the control will ignore the **[FEEDRATE OVERRIDE]** buttons.

## 85 - Maximum Corner Rounding

Defines the machining accuracy of rounded corners within a selected tolerance. The initial default value is 0.0250". If this setting is zero, the control acts as if an exact stop is commanded in each motion block. Refer also to Setting 191 (page 368) and G187 (page 317).

**F6.64:** Setting 85, Maximum Corner Rounding: [A] Programmed Point. [B] Setting 85=0.025. [C] Setting 85=0.050. [1] No Slowdown Required to Meet the Accuracy Setting. [2] A Much Lower Speed is Required to Machine into the Corner.

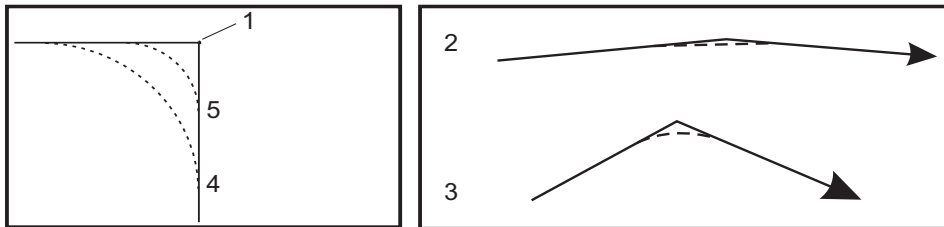

## 86 - M39 (Rotate Tool Turret) Lockout

When this setting is **ON**, the control ignores **M39** commands.

## 87 - M06 Resets Override

This is an **ON/OFF** setting. When this setting is **ON** and an **M06** is commanded, any overrides are canceled and set to their programmed values or defaults.

## 88 - Reset Resets Overrides

This is an **ON/OFF** setting. When it is **ON** and **[RESET]** is pressed, any overrides are canceled and set to their programmed values or defaults.

## 90 - Max Tools To Display

This setting limits the number of tools displayed on the Tool Geometry screen. The range of this setting is 1 to 200.

## 100 - Screen Saver Delay

When the setting is zero, the screen saver is disabled. If setting is set to some number of minutes, then after that time with no keyboard activity, the Haas logo will be displayed that will change position every 2 seconds (deactivate with any key press, **[HANDLE JOG]** movement, or alarm). The screen saver will not activate if the control is in Sleep, Jog, Edit, or Graphics mode.

## 101 - Feed Override -> Rapid

Turning this setting **ON** and pressing **[HANDLE CONTROL FEED]** causes the **[HANDLE JOG]** control to affect both the feedrate and the rapid rate overrides. Setting 10 affects the maximum rapid rate.

## 103 - CYC START/FH Same Key

The **[CYCLE START]** button must be pressed and held to run a program when this setting is **ON**. When **[CYCLE START]** is released, a feed hold is generated.

This setting cannot be turned on while Setting 104 is **ON**. When one of them is set to **ON**, the other will automatically turn off.

## 104 - Jog Handle to SNGL BLK

The **[HANDLE JOG]** control can be used to single-step through a program when this setting is **ON**. Reversing the **[HANDLE JOG]** control direction generates a feed hold.

This setting cannot be turned on while Setting 103 is **ON**. When one of them is set to **ON**, the other will automatically turn off.

## 108 - Quick Rotary G28

If this setting is **ON**, the control returns the rotary axes to zero in  $\pm 359.99$  degrees or less.

For example, if the rotary unit is at  $\pm 950.000$  degrees and a zero return is commanded, the rotary table will rotate  $\pm 230.000$  degrees to the home position if this setting is **ON**.

**NOTE:**

*The rotary axis returns to the machine home position, not the active work coordinate position.*

To use Setting 108, Parameter 43:1 (for the A Axis) and Parameter 151:1 (for the B Axis) must be set to 1. If these parameter bits are not set to 1 the control ignores Setting 108.

## 109 - Warm-Up Time in MIN.

This is the number of minutes (up to 300 minutes from power-up) during which the compensations specified in Settings 110-112 are applied.

Overview – When the machine is powered on, if Setting 109, and at least one of Settings 110, 111, or 112 are set to a nonzero value, the following warning will be displayed:



**CAUTION:**

*Warm up Compensation is specified! Do you wish to activate Warm up Compensation (Y/N)?*

If a  $\text{Y}$  is entered, the control immediately applies the total compensation (Setting 110, 111, 112), and the compensation begins to decrease as the time elapses. For instance, after 50% of the time in Setting 109 has elapsed, the compensation distance will be 50%.

To restart the time period, it is necessary to power the machine off and on, and then answer  $\text{Y}$ es to the compensation query at start-up.



**CAUTION:**

*Changing Setting 110, 111, or 112 while compensation is in progress can cause a sudden movement of up to 0.0044 inch.*

The amount of remaining warm up time is displayed on the bottom right hand corner of the Diagnostics Inputs 2 screen using the standard hh:mm:ss format.

## 110, 111, 112 - Warmup X, Y, Z Distance

Settings 110, 111, and 112 specify the amount of compensation (max =  $\pm 0.0020''$  or  $\pm 0.051$  mm) applied to the axes. Setting 109 must have a value entered for settings 110-112 to have an effect.

## 114, 115 Conveyor Cycle Time, On-Time (minutes)

Settings 114 and 115 control the optional chip conveyor. Setting 114 (Conveyor Cycle Time) is the interval that the conveyor will turn on automatically. Setting 115 (Conveyor On-Time) is the amount of time the conveyor will run. For example, if setting 114 is set to 30 and setting 115 is set to 2, the chip conveyor will turn on every half an hour, run for 2 minutes, then turn off.

On-time should be set no greater than 80% of cycle time.



### NOTE:

*The [CHIP FWD] button (or M31) will start the conveyor in the forward direction and activate the cycle.*

## 116 - Pivot Length (VR Models Only)

Setting 116 is set when the machine is first built and never changed. Only a qualified service technician should modify this setting.

## 117 - G143 Global Offset (VR Models Only)

This setting is provided for customers who have several 5-axis Haas mills and want to transfer the programs and tools from one to another. The pivot length difference (difference between Setting 116 for each machine) can be entered into this setting, and it will be applied to the G143 tool length compensation.

## 118 - M99 Bumps M30 CNTRS

When this setting is **ON**, an M99 will add one to the M30 counters (these are visible after pressing **[CURRENT COMMANDS]**).



### NOTE:

*M99 will only increase the counters as it occurs in a main program, not a sub-program.*

## 119 - Offset Lock

Turning the setting **ON** will not allow the values in the Offset display to be altered. However, programs that alter offsets will still be able to do so.

## 120 - Macro Var Lock

Turning this setting **ON** will not allow the macro variables to be altered. However, programs that alter macro variables will still be able to do so.

## 130 - Tap Retract Speed

This setting affects the retract speed during a tapping cycle (The mill must have the Rigid Tapping option). Entering a value, such as 2, will command the mill to retract the tap twice as fast as it went in. If the value is 3, it will retract three times as fast. A value of 0 or 1 will have no effect on the retract speed (Range 0-9, but the recommended range is 0-4).

Entering a value of 2 is the equivalent of using a **J** address code value of 2 for **G84** (tapping canned cycle). However, specifying a **J** code for a rigid tap will override Setting 130.

## 131 - Auto Door

This setting supports the Auto Door option. It should be set to **ON** for machines with an autodoor. Refer to **M80 / M81** (Auto Door Open / close M-codes) on page **331**.



**NOTE:**

*The M-codes work only while the machine receives a cell-safe signal from a robot. For more information, contact a robot integrator.*

The door closes when **[CYCLE START]** is pressed and opens when the program reaches an **M00**, **M01** (with Optional Stop turned **ON**), or **M30** and the spindle has stopped turning.

## 133 - REPT Rigid Tap

This setting ensures that the spindle is oriented during tapping so that the threads will line up when a second tapping pass is programmed in the same hole.



**NOTE:**

*This setting must be **ON** when a program commands peck tapping.*



## 142 - Offset Chng Tolerance

This setting generates a warning message if an offset is changed by more than the amount entered for this setting. The following prompt will be displayed: *XX changes the offset by more than Setting 142! Accept (Y/N)?* if an attempt is made to change an offset by more than the entered amount (either positive or negative).

If **Y** is entered, the control updates the offset as usual, otherwise, the change is rejected.

## 143 Machine Data Collect

This setting enables the user to extract data from the control using one or more Q commands sent through the RS-232 port, and to set Macro variables by using an E command. This feature is software-based and requires an additional computer to request, interpret and store data from the control. A hardware option also allows the reading of machine status. For detailed information, refer to the CNC Data Transfer section.

## 144 - Feed Override->Spindles

This setting is intended to keep the chip load constant when an override is applied. When this setting is **ON**, any feedrate override will also be applied to the spindle speed, and the spindle overrides will be disabled.

## 155 - Load Pocket Tables

This setting should only be used when a software upgrade is performed and/or memory has been cleared and/or the control is re-initialized. In order to replace the contents of the side-mount tool changer pocket tool table with the data from the file, the setting must be **ON**.

If this setting is **OFF** when loading an Offset file from a USB drive or RS-232, the contents of the Pocket Tool table will be unaltered. Setting 155 automatically defaults to **OFF** when the machine is turned on.

## 156 - Save Offset with PROG

Turning this setting **ON** will have the control save the offsets in the same file as the programs, but under the heading **O999999**. The offsets will appear in the file before the final **%** sign.

## 157 - Offset Format Type

This setting controls the format in which offsets are saved with programs.

When it is set to **A** the format looks like what is displayed on the control, and contains decimal points and column headings. Offsets saved in this format can be more easily edited on a PC and later reloaded.

When it is set to **B**, each offset is saved on a separate line with an N value and a V value.

## 158,159,160 - X, Y, Z Screw Thermal COMP%

These settings can be set from -30 to +30 and will adjust the existing screw thermal compensation by -30% to +30% accordingly.

## 162 - Default To Float

When this setting is **ON**, the control will add a decimal point to values entered without a decimal point (for certain address codes.) When the setting is **OFF**, values following address codes that do not include decimal points are taken as machinists notation (i.e., thousandths or ten-thousandths). The feature applies to the following address codes: X, Y, Z, A, B, C, E, F, I, J, K, U, and W.

	Value entered	With Setting Off	With Setting On
In Inch mode	X-2	X-.0002	X-2.
In MM mode	X-2	X-.002	X-2.



### NOTE:

*This setting affects the interpretation of all programs entered either manually or from disk or via RS-232. It does not alter the effect of setting 77 Scale Integer F.*

## 163 - Disable .1 Jog Rate

This setting disables the highest jog rate. If the highest jog rate is selected, the next lower rate is automatically selected instead.

## 164 - Rotary Increment

This setting applies to the **[PALLET ROTATE]** button on the EC300. It specifies the rotation for the rotary table in the load station. It should be set to a value from 0 to 360. The default value is 90. For example, entering 90 rotates the pallet 90 degrees each time the rotary index button is pressed. If it is set to zero, the rotary table will not rotate.

## 167-186 Periodic Maintenance

There are 14 items that can be monitored, as well as six spare items, in the periodic maintenance settings. These settings will allow the user to change the default number of hours for each item when it is initialized during use. If the number of hours is set to zero, the item will not appear in the list of items shown in the maintenance page of current commands.

- 167 Coolant Replacement default in power-on hours
- 169 Oil Filter Replacement default in power-on hours
- 170 Gearbox Oil Replacement default in power-on hours
- 171 Coolant Tank Level Check default in power-on hours
- 172 Way Lube Level Check default in motion-time hours
- 173 Gearbox Oil Level Check default in power-on hours
- 174 Seals/Wipers Inspection default in motion-time hours
- 175 Air Supply Filter Check default in power-on hours
- 176 Hydraulic Oil Level Check default in power-on hours
- 177 Hydraulic Filter Replacement default in motion-time hours
- 178 Grease Fittings default in motion-time hours
- 179 Grease Chuck default in motion-time hours
- 180 Grease Tool Changer Cams default in tool-changes
- 181 Spare Maintenance Setting #1 default in power-on hours
- 182 Spare Maintenance Setting #2 default in power-on hours
- 183 Spare Maintenance Setting #3 default in motion-time hours
- 184 Spare Maintenance Setting #4 default in motion-time hours
- 185 Spare Maintenance Setting #5 default in tool-changes
- 186 Spare Maintenance Setting #6 default in tool-changes

## 187 - Machine Data Echo

This setting can be set on or off. When set to **ON**, the data collection Q commands issued from the user's PC will be displayed on the PC screen. When set to **OFF**, these commands will not be displayed.

## 188, 189, 190 - G51 X, Y, Z SCALE

The axes can be scaled individually using the following new settings (must be a positive number).

Setting 188 = G51 X SCALE

Setting 189 = G51 Y SCALE

Setting 190 = G51 Z SCALE

However, if setting 71 has a value, then settings 188 - 190 are ignored and the value in setting 71 is used for scaling. If the value for setting 71 is zero, then settings 188 - 190 are used.



**NOTE:**

*When settings 188-190 are in effect, only linear interpolation, G01, is allowed. If G02 or G03 is used, alarm 467 will be generated.*

## 191 - Default Smoothness

This setting may be set to **ROUGH**, **MEDIUM**, or **FINISH** and uses parameters 302, 303, 314, 749, and 750-754 and G187 to set the smoothness and a maximum corner rounding factor. The default values are used when not overridden by a G187 command.

## 196 - Conveyor Shutdown

This specifies the amount of time to wait without activity prior to turning off the chip conveyor (and washdown coolant, if installed). Units are minutes.

## 197 - Coolant Shutdown

This specifies the amount of time to wait without activity prior to Flood, Shower, and Through-Spindle Coolant turn off in mills. Units are minutes.

## 198 - Background Color

Specifies the background color for inactive display panes. Range is 0 to 254. The default value is 235.

## 199 - Backlight Timer

Specifies the time in minutes after which the machine display backlight will turn off when there is no input at the control (except in JOG, GRAPHICS, or SLEEP mode or when an alarm is present). Press any key to restore the screen ([CANCEL] is preferred).

## 201 - Show Only Work and Tool Offsets In Use

Turning this setting on will display only the Work and Tool offsets used by the running program. The program must be run in the graphics mode first to activate this feature.

## 216 - Servo and Hydraulic Shutoff

This setting will turn the servomotors and hydraulic pump, if equipped, off after the specified number of minutes has elapsed without activity, such as running a program, jogging, button presses, etc. The default is 0.

## 238 - High Intensity Light Timer (minutes)

Specifies the duration in minutes that the High Intensity Light option (HIL) remains turned on. It can be turned on if the door is opened and the work light switch is ON. If this value is zero, then the light will remain turned on while the doors are open.

## 239 - Worklight Off Timer (minutes)

Specifies the amount of time in minutes after which the work light will turn off automatically if there are no key presses or [HANDLE JOG] control changes. If a program is running when the light turns off, the program will continue running

## 242 - Air Water Purge Interval (minutes)

This setting specifies the interval for the purge of condensates in the system air reservoir. When the time specified by setting 242 lapses, starting from midnight, the purge is begun.

## 243 - Air Water Purge On-Time (seconds)

This setting specifies the duration of the purge of condensates in the system air reservoir. The units are seconds. When the time specified by setting 242 lapses, starting from midnight, the purge is begun for the number of seconds specified by setting 243.

## 244 - Master Gage Tool Length (inches)

This setting specifies the length of the master gage that is being used to locate the tool touch off surface during setup. It is the length from the base to the tip of the master gage. It can generally be measured on a tool pre-setter gage.

## 245 - Hazardous Vibration Sensitivity

This setting selects from three sensitivity levels (**LOW**, **MEDIUM**, or **HIGH**) for the hazardous vibration sensor (in machines so equipped). This setting defaults to **HIGH** each time the machine is powered up.

## 247 - Simultaneous XYZ Motion in Tool Change

Setting 247 is a control feature that requires the Z Axis to move to the tool change position first, followed by the X and Y Axes. If Setting 247 is **OFF**, the Z Axis will retract first, followed by X- and Y-Axis motion. This feature can be useful in avoiding tool collisions for some fixture configurations. If Setting 247 is **ON**, the axes will move simultaneously. This may cause collisions between the tool and the workpiece, due to B- and C-Axis rotations. It is strongly recommended that this setting remain **OFF** on the UMC-750, due to the high potential for collisions.

## 249 - Enable Haas Startup Screen

If this setting is **ON**, a screen appears with startup instructions each time the machine is powered on. You can turn Setting 249 **ON** or **OFF** through the settings page, or you can press **[F1]** at the startup screen to turn it off.

## 900 - CNC Network Name

The control name you would like to show up on the network.

## 901 - Obtain Address Automatically

Retrieves a TCP/IP address and subnet mask from a DHCP server on a network (Requires a DHCP server). When DHCP is on, TCP/IP, SUBNET MASK and GATEWAY entries are no longer required and will have \*\*\* entered.

**NOTE:**

*The ADMIN section at the end provides the IP address from DHCP. The machine must be turned off and back on for changes to this setting to take effect.*

**NOTE:**

*To get IP settings from DHCP: At the control, go to **[LIST PROGRAM]**. Arrow down to the Hard Drive. Press the right arrow for the Hard Drive directory. Type in ADMIN and press **[INSERT]**. Select ADMIN Folder and press **[ENTER]**. Copy the IPConfig.txt file to disk or USB and read it on a Windows computer.*

## 902 - IP Address

Used on a network with static TCP/IP addresses (DHCP Off). The network administrator will assign an address (example 192.168.1.1). The machine must be turned off and back on for changes to this setting to take effect.

**NOTE:**

*The address format for Subnet Mask, Gateway and DNS is XXX.XXX.XXX.XXX (example 255.255.255.255) do not end the address with a period. The max address is 255.255.255.255; no negative numbers.*

## 903 - Subnet Mask

Used on a network with static TCP/IP addresses. The network administrator will assign a mask value. The machine must be turned off and back on for changes to this setting to take effect.

## 904 - Gateway

Used to gain access through routers. The network administrator will assign an address. The machine must be turned off and back on for changes to this setting to take effect.

## 905 - DNS Server

The Domain Name Server or Domain Host Control Protocol IP address on the network. The machine must be turned off and back on for changes to this setting to take effect.

## 906 - Domain/Workgroup Name

Tells the network which workgroup or domain the CNC control belongs to. The machine must be turned off and back on for changes to this setting to take effect.

## 907 - Remote Server Name

For Haas machines with WINCE FV 12.001 or higher, enter the NETBIOS name from the computer where the share folder resides. IP address is not supported.

## 908 - Remote Share Path

This setting contains the name of the shared network folder. To rename the shared folder after a host name is selected, enter the new shared folder name and press **[ENTER]**.



**NOTE:**

*Do not use spaces in the shared folder name.*

## 909 - User Name

This is the name used to logon to the server or domain (using a user domain account). The machine must be turned off and back on for changes to this setting to take effect. User Names are case sensitive and cannot contain spaces.



## 910 - Password

This is the password used to logon to the server. The machine must be turned off and back on for changes to this setting to take effect. Passwords are case sensitive and cannot contain spaces.

## 911 - Access to CNC Share (Off, Read, Full)

Used for the CNC hard drive read/write privileges. **OFF** stops the hard drive from being networked. **FULL** allows read/write access to the drive from the network. Turning off both this setting and Setting 913 will disable network card communication.

## 912 - Floppy Tab Enabled

Refer to Setting 914 USB Tab Enabled for this functionality. (Older software used this setting to turn access to the USB floppy drive off/on. When set to **OFF**, the USB floppy drive would not be accessible.)

## 913 - Hard Drive Tab Enabled

Turns access to the hard drive off/on. When set to **OFF**, hard drive will not be accessible. Turning off both this setting and CNC Share (Setting 911) will disable network card communication.

## 914 - USB Tab Enabled

Turns access to the USB port off/on. When set to **OFF** the USB port will not be accessible.

## 915 - Net Share

Turns access to the server drive off/on. When set to **OFF** access to the sever from the CNC control is not possible.

## 916 - Second USB Tab Enabled

Turns access to the secondary USB port off/on. When set to **OFF** the USB port will not be accessible.

## 6.5 More Information Online

For updated and supplemental information, including tips, tricks, maintenance procedures, and more, go to [www.HaasCNC.com](http://www.HaasCNC.com) and select the **Resource Center**.

# Chapter 7: Maintenance

## 7.1 Introduction

Regular maintenance is important to make sure that your machine has a long and productive life with minimal downtime. This section gives you a list of maintenance tasks that you can do yourself at the intervals listed to keep your machine running. Your dealer also offers a comprehensive preventive maintenance program that you can take advantage of for more complex maintenance tasks.

For detailed instructions on the procedures listed in this section, go to [www.HaasCNC.com](http://www.HaasCNC.com) and select the **Resource Center**.

## 7.2 Daily Maintenance

- Check the coolant level each eight-hour shift (especially during heavy TSC usage).



### NOTE:

*If your coolant system includes an auxiliary filter, do not completely fill the coolant tank at the end of the operating day. The auxiliary filter will drain approximately (5) gallons (19 liters) of coolant back into the coolant tank overnight.*

- Check the lubrication tank level.
- Clean the chips from the way covers and bottom pan.
- Clean the chips from the tool changer.
- Wipe the spindle taper with a clean rag and apply light oil.

## 7.3 Weekly Maintenance

- Check the Through-Spindle Coolant (TSC) filters. Clean or replace them if needed.
- On machines with the TSC option, clean the chip basket on the coolant tank. Do this monthly for machines without the TSC option.
- Make sure the incoming air pressure is correct. Check the spindle air pressure regulator for 15 psi for vertical mills, 25 psi for horizontal mills.
- For machines with the TSC option, put a small amount of grease on each tool holder pull stud. Do this monthly for machines without the TSC option.
- Clean all of the exterior surfaces with mild cleaner. DO NOT use solvents.
- Check the hydraulic counterbalance pressure according to the machine's specifications.

---

## 7.4 Monthly Maintenance

- Check the oil level in the gear box (if equipped).
- Inspect way covers for proper operation and lubricate them with light oil, if necessary.
- Place a small amount of grease on the outside edge of the guide rails of the tool changer and run through all tools.
- Check the SMTC oil level (if equipped).
- EC-400: Clean the locating pads on the A Axis and the load station.
- For machines with umbrella-style tool changers, put grease on the V-flange of each tool holder.
- Check for dust buildup on electrical cabinet vector drive vents (beneath power switch). If buildup exists, open cabinet and wipe vents with a clean cloth rag. Apply compressed air as necessary to remove dust accumulation.

## 7.5 Every (6) Months

- Replace coolant and thoroughly clean the coolant tank.
- Check all hoses and lubrication lines for cracking.
- Check the rotary A Axis, if equipped. Add lubrication, if needed.

## 7.6 Annual Maintenance

- Replace the gearbox oil (if equipped).
- Clean the oil filter inside the lubrication panel oil reservoir and clean out the residue at the bottom of the filter.
- VR Machines: replace the A and B Axis gear oil.

---

# Chapter 8: Other Machine Manuals

## 8.1 Introduction

Some Haas machines have unique characteristics which are beyond the scope of this manual to describe. These machines come with a printed manual addendum, but you can also download them at [www.haascnc.com](http://www.haascnc.com).

## 8.2 Mini Mills

Mini Mills are versatile and compact vertical mills.

## 8.3 VF-Trunnion Series

These vertical mills come standard with a TR-series rotary unit pre-installed for five-axis applications.

## 8.4 Gantry Routers

Gantry Routers are large-capacity open-frame vertical mills, suitable for milling and routing applications.

## 8.5 Office Mill

The Office Mill series are compact small-scale vertical mills that can fit through a standard door frame and run on single-phase power.

## 8.6 EC-400 Pallet Pool

The EC-400 Pallet Pool increases productivity with a multi-station pallet pool and innovative scheduling software.

## 8.7 UMC-750

The UMC-750 is a versatile five-axis mill that features an integrated dual-axis trunnion table.



# Index

<b>#</b>	
3D cutter compensation (G141).....	295
unit vector example .....	296
<b>A</b>	
absolute positioning (G90)	
versus incremental .....	143
active codes.....	47
active codes display	
current commands .....	49
active program.....	77
active tool display.....	48
advanced editor .....	115
edit menu .....	118
modify menu .....	122
pop-up menu .....	116
program menu.....	116
search menu.....	120
text selection.....	119
Advanced Tool Management .....	50
Advanced Tool Management (ATM).....	91
macros and .....	94
tool group setup.....	93
tool group usage.....	94
auto door (option)	
override .....	33
axis motion	
absolute versus incremental.....	143
circular .....	149
linear.....	148
axis overload timer .....	109
<b>B</b>	
b on a axis offset.....	175
background edit .....	113
basic program example	
completion block.....	143
cutting block .....	143
preparation block.....	142
beacon light	
status .....	33
boring and reaming canned cycles.....	160
BT tooling.....	88
<b>C</b>	
calculator	
circle .....	70
circle-circle tangent .....	73
circle-line tangent .....	72
triangle .....	69
canned cycles	
boring and reaming .....	160
drilling .....	160
r plane and .....	161
tapping .....	160
circular interpolation .....	149
clipboard	
copy to .....	120
cut to .....	119
paste from.....	120
communications	
RS-232.....	81
control cabinet	
secure latches .....	2
control display	
active codes .....	47
active pane .....	45
active tool .....	48
basic layout .....	45
offsets .....	47

control pendant .....	32–33
front panel controls .....	32
USB port.....	33
coolant	
operator override .....	44
setting 32 and .....	347
coolant level gauge .....	48
copying files.....	78
CT tooling .....	88
current commands .....	49
additional setup.....	107
cutter compensation	
circular interpolation and .....	157
entry and exit.....	154
feed adjustments .....	155
general description .....	151
improper application example.....	155
Setting 58 and .....	151
<b>D</b>	
data collection .....	82
spare M-codes .....	84
with RS-232 .....	82
deleting programs .....	79
device manager.....	76
program selection .....	77
DIR FULL message.....	80
direct numeric control (DNC) .....	85
operating notes .....	86
distance to go position .....	51
doors	
interlocks .....	2
drilling canned cycles.....	160
drip mode .....	86
dry run.....	107
duplicating a program .....	80
dxf file importer .....	138
dxf importer	
chain and group .....	139
part origin .....	139
toolpath selection .....	140
dynamic work offset (G254).....	318

<b>E</b>	
edit keys	
ALTER.....	112
DELETE .....	112
INSERT .....	112
UNDO.....	113
editing	
highlight code .....	112
<b>F</b>	
feed adjustments	
in cutter compensation .....	155
feed hold	
as override.....	44
file directory system .....	77
directory creation .....	77
navigation.....	77
file numeric control (FNC).....	84
display footer.....	126
display modes .....	125
FNC editor .....	124
loading a program .....	124
menus .....	125
opening multiple programs .....	126
file numeric control (FNC) editor	
text selection.....	130
files	
copying .....	78
folder, See directory structure	
<b>G</b>	
gauges display	
coolant.....	48
G-codes .....	230
canned cycles .....	160, 231
cutting.....	148
graphics mode .....	86
<b>H</b>	
hazards .....	1
environmental.....	4



help		machine	
calculator .....	68	operating limits .....	3
drill table .....	68	machine position .....	51
keyword search .....	67	machine power-up .....	75
tabbed menu .....	67	macro variables	
help function .....	66	current commands display .....	49
high-speed SMTC		macros	
heavy tools and .....	99	M30 counters and .....	48
<b>I</b>		main spindle display .....	64
icon bar .....	53	maintenance .....	375
incremental positioning (G91)		current commands .....	50
versus absolute .....	143	manual data input (MDI) .....	114
input bar .....	53	material	
interpolation motion		fire risk .....	4
circular .....	149	M-code	
linear .....	148	M06 tool change .....	147
Intuitive Programming System (IPS)		M-codes .....	322
dxf importer and .....	138	coolant commands .....	148
<b>J</b>		program stop .....	147
jobs		spindle commands .....	147
set-up, safety .....	3	memory lock .....	33
jog mode		mode display .....	46
part setup and .....	104	<b>O</b>	
<b>K</b>		O09xxx program numbers .....	111
keyboard		offset	
alpha keys .....	41	tool .....	146
cursor keys .....	36	work .....	146
display keys .....	37	offsets	
function keys .....	35	displays .....	47
jog keys .....	42	operating modes .....	46
key groups .....	34	operation	
mode keys .....	38	device manager .....	76
numeric keys .....	41	dry run .....	107
override keys .....	43	unattended .....	4
<b>L</b>		operator position .....	51
linear interpolation .....	148	optional stop .....	322
local subroutines (M97) .....	165	overrides .....	43
<b>M</b>		disabling .....	43
M30 counters .....	48	<b>P</b>	
		part setup .....	103
		offsets .....	104
		tool offsets .....	106
		work offset .....	105

parts	
damaged .....	2
hazards .....	3
loading and unloading, safety .....	3
position display .....	51
axis selection .....	52
current commands .....	49
positioning	
absolute vs. incremental .....	143
positions	
distance to go .....	51
machine .....	51
operator.....	51
work (G54) .....	51
program	
active .....	77
line numbers	
removal.....	122
program names	
Onnnnn format.....	78
program number change .....	80
program numbers	
change in memory .....	80
O09xxx.....	111
program optimizer .....	137
screen.....	137
program selection .....	77
programming	
basic example.....	140
safe startup line.....	142
subroutines .....	163
programs	
.nc file extension .....	78
basic editing .....	111
basic search .....	81
changing a program number .....	80
deleting .....	79
duplication .....	80
file naming .....	78
maximum number of .....	80
running.....	107
transfer.....	78

## R

r plane .....	161
---------------	-----

robot cell	
integration .....	5
RS-232.....	81
cable length .....	82
data collection .....	82
DNC and .....	85
DNC settings.....	85
running programs .....	107
run-stop-jog-continue .....	108

## S

safe startup line.....	142
safety	
decals.....	8
during operation.....	2
electrical.....	2
electrical panel .....	2
eye and ear protection.....	1
hazardous material .....	2
keyswitch operation .....	5
robot cells.....	5
spindle head .....	2
tool changer .....	2
safety decals	
general .....	9
other.....	10
standard layout.....	8
safety modes	
setup .....	4
second home.....	33
Servo Auto Door.....	222
setting 247 .....	370
Settings .....	340
settings	
list.....	337
setup mode	
keyswitch .....	33
shop roles	
machine cleaner .....	3

side-mount tool changer (SMTC)	
door panel.....	103
extra-large tools .....	101
moving tools .....	100
recovery .....	102
tool loading .....	97
zero pocket designation .....	99
special G-codes	
engraving.....	161
mirror image.....	162
pocket milling.....	162
rotation and scaling.....	162
spindle load meter.....	65
spindle warm-up .....	75
subprograms, See subroutines	
subroutines.....	163
external .....	163
local.....	165
<b>T</b>	
tabbed menus	
basic navigation .....	65
tapping canned cycles .....	160
text selection	
advanced editor and.....	119
FNC editor and .....	130
Through Spindle Coolant	
TSC.....	160, 223, 332
Through-Spindle Coolant	
TSC.....	42, 64, 108
timers and counters display.....	48
tool center point control (G234).....	318
tool changer.....	95
damage .....	3
safety .....	2, 96
tool diameter .....	97
tool life display	
current commands .....	49
tool load limits .....	107
tool loading	
large / heavy tools .....	97
tool management tables	
save and restore .....	95
tool offset .....	146
tool offsets.....	106

tooling	
pull studs.....	89
Tnn code.....	87
tool holder care.....	88
tool holders.....	88
tools	
damaged.....	2
injury by .....	2
loading and unloading, safety .....	3
<b>U</b>	
umbrella tool changer	
loading.....	101
recovery .....	102
unattended operation	
fire risk and.....	4
USB device .....	76
<b>W</b>	
work (G54) position.....	51
work offset .....	105, 146
workholding.....	103

